

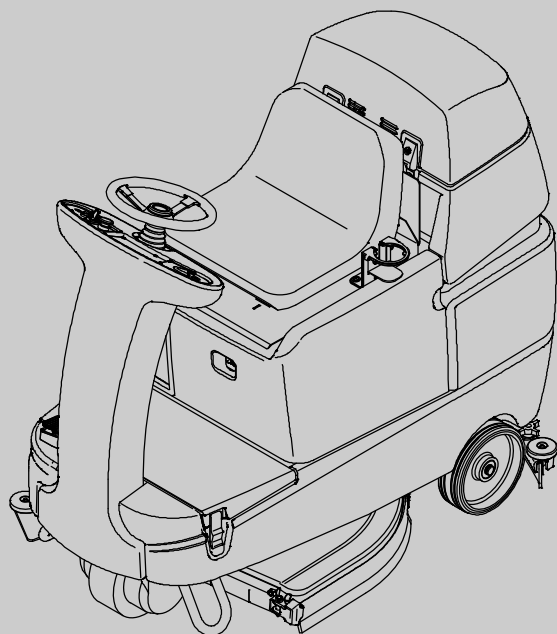

T7+

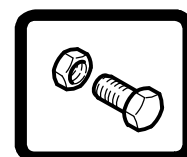

Rider Scrubber Parts Manual



(S/N 10000-)



Hygenic[®] Fully Cleanable Tanks
TennantTrue[®] Parts
IRIS[®] a Tennant Technology

Europe



For the latest Parts manuals and other language Operator manuals, visit:

www.tennantco.com/manual

9013336

Rev. 08 (04-2023)



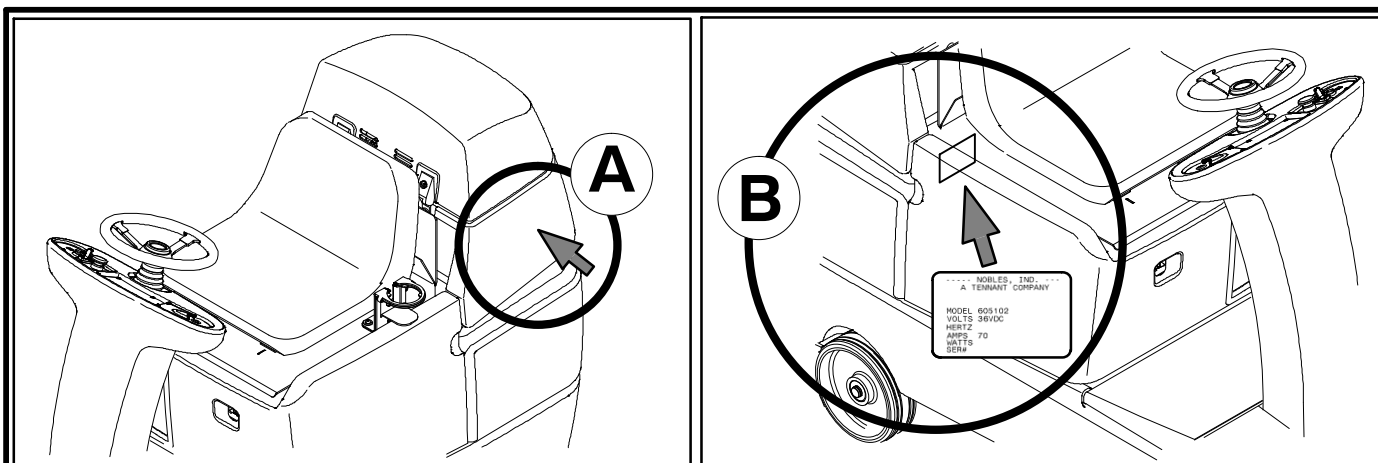

Ref	Part No.	Serial Number	Description	Qty.
1	82681	(00000—)	Bracket Wldt, Lpg Mount	1
▽ 2	63810	(00000—)	Latch Assy, Lpg Tank Mtg, W/Nut	4
▲ 3	51839	(00000—)	Nut Adjustable, Lpg Tank Mtg	2
4	49263	(00000—)	Tie, Cable	3
(D) 5	82556	(00000—001039)	Bracket, Vaporizer	1
	54930	(00000—)	Vaporizer, LPG	1

HOW TO ORDER PARTS – See diagram above

Only use TENNANT Company supplied or equivalent parts. Parts and supplies may be ordered online, by phone, by fax or by mail.

Follow the steps below to ensure prompt delivery.

1. **(A)** Identify the machine model.
2. **(B)** Identify the machine serial number from the data plate.
3. **(C)** Ensure the proper serial number is used from the parts list.
4. Identify the part number and quantity.
Do not order by page or reference numbers.
5. Provide your name, company name, customer ID number, billing and shipping address, phone number and purchase order number.
6. Provide detail shipping instructions.

(D) ▽ – identifies an assembly
▲ – identifies parts included in assembly

EN

Please fill out at time of installation for future reference.

Model No. – _____

Serial No. – _____

Machine Options – _____

Sales Rep. – _____

Sales Rep. phone no. – _____

Customer ID Number – _____

Installation Date – _____

Tennant N.V.
 Industrielaan 6 5405 AB
 P.O. Box 6 5400 AA Uden–The Netherlands
 europe@tennantco.com
 www.tennantco.com

Specifications and parts are subject to change without notice.

Copyright © 2014–2023 TENNANT Company. All Rights Reserved.

BG	<p>КАК ДА ПОРЪЧВАМЕ ЧАСТИ - Вижте схемата по-горе</p> <p>Използвайте само части, доставени от TENNANT или техни еквиваленти. Частите и доставките могат да се поръчат онлайн, по телефон, факс или по пощата.</p> <p>Следвайте долупосочените стъпки, за да си осигурите бърза и точна доставка.</p> <ol style="list-style-type: none"> (A) Посочете модела на машината. (B) Посочете серийния номер на машината от табелката с техническите данни. (C) Уверете се, че сте използвали точния серийен номер от списъка с части. Посочва номера на частта и количеството. Не поръчвайте части според страницата или референтните номера. Посочете своето име, наименованието на фирмата, клиентския номер, адреса за получаване на сметката и доставката, тел.номер и номера на поръчката. Посочете подробни инструкции за доставката. <hr/> <p>(D) ▽ – посочва начин на монтаж ▲ – посочва частите, включени в монтажа</p>	<p>Моля, попълнете по време на монтажа за бъдеща справка.</p> <p>Модел Э – _____</p> <p>Серийен Э – _____</p> <p>Опции на машината – _____</p> <p>Търговски представител – _____</p> <p>Тел. Э на търг. представител – _____</p> <p>Клиентски Э – _____</p> <p>Дата на монтаж – _____</p>
-----------	--	--

CN	<p>如何订购部件 – 参见下表</p> <p>仅使用 TENNANT 公司提供的或同等部件。部件和供应可以在线订购，通过电话、传真或邮件订购。</p> <p>请遵循下面的步骤确保及时交付。</p> <ol style="list-style-type: none"> (A) 确定机器型号。 (B) 从数据标签确定机器序列号。 (C) 确保使用部件列表中的正确序列号。 确定部件号和数量。 不要按页面或参考编号订购。 提供您的姓名、公司名称、客户 ID 号、付帐和送货地址、电话号码和采购单编号。 提供详细的送货说明。 <hr/> <p>(D) ▽ – 确定组件 ▲ – 确定组件中包含的组件</p>	<p>请在安装时填写供未来参考。</p> <p>型号 – _____</p> <p>序列号 – _____</p> <p>机器选项 – _____</p> <p>销售代表 – _____</p> <p>销售代表电话号码 – _____</p> <p>客户 ID 编号 – _____</p> <p>安装日期 – _____</p>
-----------	--	--

CZ	<p>OBJEDNÁVÁNÍ DÍLŮ - Viz schéma výše.</p> <p>Používejte pouze díly dodané společností TENNANT Company nebo jim odpovídající. Díly a materiál lze objednat online, telefonem, faxem nebo poštou.</p> <p>Aby bylo zajištěno rychlé dodání, postupujte podle kroků uvedených níže.</p> <ol style="list-style-type: none"> (A) Zjistěte model stroje. (B) Zjistěte sériové číslo stroje z výrobního štítku. (C) Použijte správné sériové číslo ze seznamu dílů. Určete číslo a množství dílů. Neobjednávejte podle stran nebo referenčních čísel. Uveďte jméno, název společnosti, číslo ID zákazníka, fakturační a dodací adresu, telefonní číslo a číslo objednávky. Uveďte podrobné pokyny pro dodání. <hr/> <p>(D) ▽ – označuje sestavu ▲ – označuje díly v sestavě</p>	<p>Vypíšte během sestavování pro budoucí potřebu.</p> <p>Číslo modelu – _____</p> <p>Sériové číslo – _____</p> <p>Doplňky zařízení – _____</p> <p>Obchodní zástupce – _____</p> <p>Tel. č. obchodního zástupce – _____</p> <p>Číslo ID zákazníka – _____</p> <p>Datum instalace – _____</p>
-----------	---	--

DE	<p>BESTELLEN VON ERSATZTEILEN – Siehe oben stehendes Diagramm.</p> <p>Verwenden Sie nur von TENNANT gelieferte oder gleichwertige Ersatzteile. Ersatz- und Verschleißteile können online, telefonisch, per Fax oder per E-Mail bestellt werden.</p> <p>Befolgen Sie für eine umgehende Lieferung die folgenden Schritte.</p> <ol style="list-style-type: none"> (A) Geben Sie das Modell der Maschine an. (B) Geben Sie die Seriennummer der Maschine an (auf dem Datenaufkleber). (C) Achten Sie darauf, dass die richtigen Seriennummer aus der Ersatzteilliste verwendet wird. Geben Sie die Ersatzteilnummer und die Menge an. Bestellen Sie nicht nach Seitenzahl oder Referenznummern. Geben Sie Ihren Namen, den Firmennamen, die Kundennummer, die Rechnungs- und Lieferadresse, die Telefonnummer und die Einkaufsauftragsnummer an. Erteilen Sie genaue Versandanweisungen. <hr/> <p>(D) ▽ – steht für eine Einheit ▲ – steht für Einzelteile einer Einheit</p>	<p>Bitte bei der Inbetriebnahme als Referenzangabe ausfüllen.</p> <p>Modellnr. – _____</p> <p>Seriennr. – _____</p> <p>Maschinenoptionen – _____</p> <p>Verkäufer – _____</p> <p>Telefonnummer des Verkäufers – _____</p> <p>Kundennummer – _____</p> <p>Installationsdatum – _____</p>
-----------	--	--

DK	<p>BESTILLING AF RESERVEDELE – Se ovenstående tabel.</p> <p>Brug kun reservedele, der er fremstillet af TENNANT, eller dele af tilsvarende kvalitet. Reservedele og tilbehør kan bestilles online, pr. telefon, pr. fax eller pr. brev.</p> <p>Følg nedenstående trin for at sikre hurtig levering.</p> <ol style="list-style-type: none"> (A) Identificér maskinmodellen. (B) Identificér maskinens serienummer på datamærkatet. (C) Kontrollér, at det rigtige serienummer bruges i reservedelslisten. Identificér reservedelsnummeret og antallet. Bestil ikke efter side- eller referencenumre. Angiv dit navn, firmanavn, kunde-id-nummer, faktureringsadresse og leveringsadresse, telefonnummer og indkøbsordrenummer. Angiv detaljerede instruktioner til forsendelse. <hr/> <p>(D) ▽ – identificer en enhed ▲ – identificer reservedele i en enhed</p>	<p>Udfyld venligst på installationstidspunktet til fremtidig brug.</p> <p>Modelnr. – _____</p> <p>Serienr. – _____</p> <p>Maskineks-traudstyr – _____</p> <p>Salgskonsulent. – _____</p> <p>Salgskonsulentens tlf. – _____</p> <p>Kunde-id-nr. – _____</p> <p>Installationsdato – _____</p>
-----------	--	--

EE	<p>KUIDAS VARUOSI TELLIDA – vaadake alltoodud joonist</p> <p>Kasutage ainult TENNANT Company poolt tarnitud või samaväärseid varuosid. Varuosi ja tarvikuid saab tellida Interneti, telefoni, faksi või posti teel.</p> <p>Kiire kohaletoimetamise tagamiseks järgige alltoodud juhiseid.</p> <ol style="list-style-type: none"> (A) Märkige masina mudel. (B) Märkige andmesildil olev masina seerianumber. (C) Veenduge, et olete valinud varuosade loendist õige seerianumbri. Märkige varuosa number ja kogus. Ärge tellige lehekülje- või viitenumbri alusel. Märkige oma nimi, ettevõtte nimi, kliendinumbr ja arveldus- ja saatmisadress, telefoninumber ja ostutellimuse number. Lisage täpsed saatmisjuhised. <hr/> <p>(D) ▽ – tähistab komplekti ▲ – tähistab komplektis olevaid osi</p>	<p>Palun täitke paigaldamise ajal edaspidiseks viitamiseks.</p> <p>Mudelil number – _____</p> <p>Seerianumber – _____</p> <p>Masina lisavarustus – _____</p> <p>Müügiesindus – _____</p> <p>Müügiesinduse telefoninumber – _____</p> <p>Kliendinumber – _____</p> <p>Paigaldamise kuupäev – _____</p>
-----------	---	--

ES	<p>CÓMO SOLICITAR PIEZAS – Consulte el diagrama anterior.</p> <p>Utilice sólo las piezas suministradas por TENNANT Company o piezas equivalentes. Puede solicitar las piezas a través de internet, por teléfono, por fax o por correo.</p> <p>Siga los siguientes pasos para que la entrega sea rápida.</p> <ol style="list-style-type: none"> (A) Indique el modelo de máquina. (B) Indique el número de serie de la etiqueta de datos. (C) Asegúrese de que indica el número de serie correcto de la lista de piezas. Indique la cantidad y el número de la pieza. No realice el pedido indicando el número de página o el de referencia. Incluya su nombre, el nombre de la empresa, el ID de cliente, las direcciones de envío y facturación, el número de teléfono y el número del pedido de compra. Facilite instrucciones de envío. <hr/> <p>(D) ▽ – identifica un conjunto ▲ – identifica piezas de un conjunto</p>	<p>Rellene estos datos cuando realice la instalación para utilizarlos como referencia en el futuro.</p> <p>Nº modelo – _____</p> <p>Nº serie – _____</p> <p>Opciones de la máquina – _____</p> <p>Vendedor – _____</p> <p>Nº teléfono vendedor – _____</p> <p>Nº cliente – _____</p> <p>Fecha de instalación – _____</p>
-----------	--	---

FI	<p>KUINKA VARAOSIA TILATAAN – katso kuvaa yllä.</p> <p>Käytä ainoastaan TENNANTIN toimittamia tai niitä vastaavia varaosia. Voit tilata varaosia ja tarvikkeita internetistä, puhelimitse, faksilla tai sähköpostilla.</p> <p>Noudata seuraavia ohjeita täsmällisen toimituksen varmistamiseksi.</p> <ol style="list-style-type: none"> (A) Katso koneen malli. (B) Katso koneen sarjanumero sen tunnustarrasta. (C) Varmista, että osaluettelosta, että käytät oikeaa sarjanumeroa. Katso osanumero ja kappalemäärä. Älä tilaa ilmoittamalla sivu- tai viitenumeroita. Ilmoita nimesi, yrityksesi nimi, asiakasnumero, laskutus- ja toimitusosoite, puhelinnumero ja ostotilauksen numero. Ilmoita yksityiskohtaiset toimitusosoitteet. <hr/> <p>(D) ▽ – tarkoittaa kokoonpanoa ▲ – tarkoittaa kokoonpanoon sisältyviä osia</p>	<p>Ole hyvä ja täytä ottaessasi koneen käyttöön myöhempiä tarpeita varten.</p> <p>Mallinnumero – _____</p> <p>Sarjanumero – _____</p> <p>Koneen lisävarusteet – _____</p> <p>Myyntiedustaja – _____</p> <p>Myyntiedustajan puhelinnumero – _____</p> <p>Asiakasnumero – _____</p> <p>Asennuspäivä – _____</p>
-----------	---	--

FR	<p>COMMENT COMMANDER DES PIÈCES DÉTACHÉES – Voir le schéma ci-dessus.</p> <p>Utilisez uniquement des pièces fournies par la société TENNANT ou équivalentes. Les pièces et fournitures peuvent être commandées en ligne, par téléphone, fax, ou par courrier.</p> <p>Suivez les étapes ci-dessous pour assurer une livraison rapide.</p> <ol style="list-style-type: none"> 1. (A) Identifiez le modèle de la machine. 2. (B) Identifiez le numéro de série de la machine, à partir de l'étiquette signalétique. 3. (C) Assurez-vous que le numéro de série correct est utilisé à partir de la liste de pièces détachées. 4. Identifiez le numéro de pièce et la quantité. Ne commandez pas par page ou numéros de référence. 5. Fournissez votre nom, le nom de votre société, votre numéro d'identification de client, l'adresse de facturation et d'expédition, le numéro de téléphone et le numéro du bon de commande. 6. Fournissez des instructions d'expédition détaillées. <hr/> <p>(D) ▽ – identifie un assemblage ▲ – identifie les pièces composant l'assemblage</p>	<p>A remplir au moment de l'installation à titre de référence.</p> <p>N° du modèle – _____</p> <p>N° de série – _____</p> <p>Options de la machine – _____</p> <p>Agent commercial – _____</p> <p>N° tél. de l'agent commercial – _____</p> <p>Numéro d'identification client – _____</p> <p>Date d'installation – _____</p>
-----------	---	---

GR	<p>ΤΡΟΠΟΣ ΠΑΡΑΓΓΕΛΙΑΣ ΑΝΤΑΛΛΑΚΤΙΚΩΝ - Βλ. παραπάνω διάγραμμα.</p> <p>Χρησιμοποιήστε μόνο ανταλλακτικά παρεχόμενα από την TENNANT Company ή ισοδύναμα. Τα ανταλλακτικά και αναλώσιμα μπορούν να παραγγελθούν online, τηλεφωνικά, με φαξ ή ταχυδρομικά.</p> <p>Ακολουθήστε τα παρακάτω βήματα για να εξασφαλίσετε την έγκαιρη αποστολή τους.</p> <ol style="list-style-type: none"> 1. (A) Βρείτε το μοντέλο μηχανήματος. 2. (B) Βρείτε τον αριθμό σειράς του μηχανήματος από την ετικέτα στοιχείων. 3. (C) Βεβαιωθείτε ότι χρησιμοποιείται ο σωστός αριθμός σειράς από τον κατάλογο ανταλλακτικών. 4. Βρείτε κωδικό ανταλλακτικού και ποσότητα. Μην παραγγέλνετε βάσει σελίδας ή αριθμών αναφοράς. 5. Δώστε το όνομα σας, όνομα εταιρείας, ID (κωδικό) πελάτη, διεύθυνση τιμολόγησης και αποστολής, αριθμό τηλεφώνου και αριθμό εντολής προμήθειας. 6. Δώστε λεπτομερείς πληροφορίες αποστολής. <hr/> <p>(D) ▽ – υποδηλώνει υποσύστημα ▲ – υποδηλώνει τα μέρη που περιλαμβάνονται στο υποσύστημα</p>	<p>Παρακαλούμε συμπληρώστε κατά την ώρα της εγκατάστασης για μελλοντική αναφορά.</p> <p>Αρ. Μοντέλου – _____</p> <p>Αρ. σειράς – _____</p> <p>Επιλογές Μηχανήματος – _____</p> <p>Εκπ. πωλήσεων – _____</p> <p>Τηλ. εκπροσώπου πωλήσεων – _____</p> <p>Αριθμός πελάτη – _____</p> <p>Ημερομηνία εγκατάστασης – _____</p>
-----------	---	---

HU	<p>HOGYAN RENDELJÜNK ALKATRÉSZEKET - Lásd: fenti diagramm.</p> <p>Kizárólag TENNANT vagy azzal egyenértékű cserealkatrészeket használjon. Az alkatrészeket és anyagokat meg lehet rendelni az Interneten keresztül, vagy telefonon, faxon és e-mailben.</p> <p>A pontos szállítás érdekében kövesse az alábbi lépéseket.</p> <ol style="list-style-type: none"> 1. (A) Adja meg a gép típusát. 2. (B) Az adatcímke alapján adja meg a gép gyártási számát. 3. (C) Ügyeljen arra, hogy a megfelelő gyártási számot válassza ki az alkatrészlistáról. 4. Adja meg a rendelési számot és a mennyiséget. A rendeléshez ne az oldalszámot vagy a hivatkozási számot használja. 5. Adja meg a nevét, a cége nevét, az ügyfélaazonosító számát, a számlázási és szállítási címét, a telefonszámát és a rendelési számot. 6. Adjon részletes szállítási utasításokat. <hr/> <p>(D) ▽ – a jel csomagra utal ▲ – a jel a csomagban található alkatrészekre utal</p>	<p>A későbbi visszakeresések érdekében kérjük, hogy a rovatokat az első üzembehelyezéskor töltsse ki.</p> <p>Típuszám – _____</p> <p>Gyártási szám. – _____</p> <p>A gép felszereltsége – _____</p> <p>Kereskedelmi képviselő – _____</p> <p>Kereskedelmi képviselő telefonszáma – _____</p> <p>Ügyfél azonosító száma – _____</p> <p>Üzembehelyezés dátuma – _____</p>
-----------	---	--

IT	<p>COME ORDINARE LE PARTI – Vedere schema precedente.</p> <p>Utilizzare solo ricambi forniti da TENNANT o equivalenti. Ricambi e forniture possono essere ordinati online, per telefono, via fax o per posta elettronica.</p> <p>Per ottenere una consegna rapida, seguire i passaggi indicati di seguito.</p> <ol style="list-style-type: none"> 1. (A) Identificare il modello della macchina. 2. (B) Identificare il numero di serie della macchina dall'etichetta dei dati. 3. (C) Utilizzare il numero di serie corretto presente nell'elenco delle parti di ricambio. 4. Identificare numero di parte e quantità. Non ordinare per numero di pagina o di riferimento. 5. Fornire nome del contatto, nome della società, numero di ID cliente, indirizzo di fatturazione e di spedizione, numero di telefono e numero di ordine di acquisto. 6. Fornire istruzioni dettagliate per la spedizione. <hr/> <p>(D) ▽ – identifica un gruppo ▲ – identifica parti comprese in un gruppo</p>	<p>Compilare il modulo al momento dell'installazione per poterlo consultare in futuro in caso di necessità.</p> <p>N. Modello – _____</p> <p>N. Serie – _____</p> <p>Opzioni della macchina – _____</p> <p>Venditore – _____</p> <p>Tel. venditore – _____</p> <p>Numero ID cliente – _____</p> <p>Data di installazione – _____</p>
-----------	---	---

JP	<p>パーツの発注方法 ? 上記の図を参照してください</p> <p>TENNANT社製のパーツまたは同等品のみをお使いください。 パーツやサプライ品のご注文は、オンライン、電話、FAX、または手紙でお願いいたします。 確実にお届けできるように、以下の情報お知らせください。</p> <ol style="list-style-type: none"> (A) 製品のモデル名をお知らせください。 (B) 製品のデータラベルに印刷されているシリアル番号をお知らせください。 (C) パーツリストを参照して、シリアル番号が正しいかご確認ください。 パーツ番号と数量をお知らせください。マニュアル/カタログのページ番号や参照番号でのご注文はご遠慮ください。 お客様のお名前、会社名、顧客ID番号、請求/発送先住所、電話番号、注文書番号をお知らせください。 発送に関するご希望があれば、明記してください。 <hr/> <p>(D) ▽ - アセンブリを示します ▲ - アセンブリに含まれるパーツを示します</p>	<p>後日確認できるように、設置時に記入してください。</p> <p>モデルNo. - _____</p> <p>シリアルNo. - _____</p> <p>製品のオプション - _____</p> <p>販売代理店 - _____</p> <p>販売代理店の電話番号 - _____</p> <p>顧客ID番号 - _____</p> <p>設置日 - _____</p>
-----------	---	---

LT	<p>KAIP UŽSISAKYTI DALIS – žr. diagramą viršuje</p> <p>Naudokite tik "Tennant" kompanijos tiekiamas arba lygiavertes joms dalis. Dalis galite užsisakyti internetu, telefonu, faksu bei elektroniniu paštu. Kad užsakymas būtų greitai įvykdytas, laikykitės išvardytų taisyklių.</p> <ol style="list-style-type: none"> (A) Nurodykite mašinos modelį. (B) Norodyskite mašinos serijos numerį, kurį rasite ant duomenų žymės. (C) Įsitinkinkite, kad nurodomas tikslus serijos numeris iš dalių sąrašo. Nurodykite dalies numerį ir reikiamą kiekį. Neužsakinėkite pagal puslapius ar nuorodos numerius. Nurodykite savo vardą, kompanijos pavadinimą, kliento ID numerį, sąskaitos išrašymo ir vežimo adresą, telefono numerį ir pirkimo užsakymo numerį. Nurodykite išsamias gabenimo instrukcijas. <hr/> <p>(D) ▽ – žymi sistemą ▲ – nurodo sistemos dalis</p>	<p>Prašome užpildyti montavimo metu, siekiant gauti informaciją ateityje.</p> <p>Modelio nr. - _____</p> <p>Serijos nr. - _____</p> <p>Mašinos parinktis - _____</p> <p>Prekybos atstovas - _____</p> <p>Komivojažieriaus tel. nr. - _____</p> <p>Pirkėjo ID numeris - _____</p> <p>Sumontavimo data - _____</p>
-----------	---	---

LV	<p>KĀ PASŪTĪT REZERVES DETALĀS – Skat. diagrammu iepriekš</p> <p>izmantojiet tikai TENNANT Company piegādātās vai tām līdzvērtīgas rezerves detaļas. Daļas un piegādi var pasūtīt internetā, pa tālruni, pa faksu vai pastu. Lai nodrošinātu savlaicīgu piegādi, sekojiet zemāk aprakstītajiem soļiem.</p> <ol style="list-style-type: none"> (A) Nosakiet mašinas modeli. (B) Nosakiet mašinas sērijas numuru un tehnisko datu uzlīmes. (C) Pārliedcinieties, ka tiek uzrakstīts attiecīgais sērijas numurs no detaļu saraksta. Nosakiet detaļas numuru un skaitu. Veicot pasūtījumus neatsaucieties uz lapušu vai norādes numuriem. Uzrakstiet savu vārdu, uzņēmuma nosaukumi, klienta identitātes numuru, adresi rēķina piesūtīšanai un piegādei un pirkuma pasūtījuma numuru. Sniedziet detalizētu informāciju par piegādi. <hr/> <p>(D) ▽ – nosaka ierīci ▲ – nosaka detaļas, kas ir komplektā ar ierīci</p>	<p>Veicot uzstādīšanu, lūdzam pierakstīt attiecīgo informāciju izmantošanai turpmāk.</p> <p>Modeļa Nr. - _____</p> <p>Sērijas Nr. - _____</p> <p>Iekārtas papildaprīkojums - _____</p> <p>Pārdošanas pārst. - _____</p> <p>Pārdošanas pārst. tālr. Nr. - _____</p> <p>Klienta identitātes numuru - _____</p> <p>Uzstādīšanas datums - _____</p>
-----------	--	--

NL	<p>HOE ONDERDELEN TE BESTELLEN – Zie schema hierboven.</p> <p>Gebruik alleen onderdelen die door TENNANT Company zijn geleverd of soortgelijke onderdelen. Onderdelen en voorraden kunnen online, per telefoon, fax of schriftelijk besteld worden. Volg de stappen hieronder om een juiste levering te garanderen.</p> <ol style="list-style-type: none"> (A) Bepaal het machinemodel. (B) Lees het serienummer van de machine af van het gegevenslabel. (C) Zorg dat het juiste serienummer wordt gebruikt uit de onderdelenlijst. Bepaal het artikelnummer en het aantal. Bestel niet aan de hand van pagina's of referentienummers Geef uw naam, bedrijfsnaam, klantnummer, factuur- en leveringsadres, telefoonnummer en bestelnummer op. Geef gedetailleerde leveringsinstructies op. <hr/> <p>(D) ▽ – geeft een eenheid aan ▲ – geeft de onderdelen van de eenheid aan</p>	<p>Vul tijdens installatie de onderstaande gegevens in voor eventueel toekomstig gebruik.</p> <p>Modelnr. - _____</p> <p>Serienr. - _____</p> <p>Machine-opties - _____</p> <p>Verkoopvert. - _____</p> <p>Telnr. verkoopvert. - _____</p> <p>Klantnummer - _____</p> <p>Installatiedatum - _____</p>
-----------	--	--

NO	<p>HVORDAN BESTILLE DELER – Se diagram over.</p> <p>Bruk kun deler levert av TENNANT Company eller ekvivalente deler. Deler og forsyninger kan bestilles online, per telefon, per faks eller per post.</p> <p>Følg trinnene under for å sikre rask levering.</p> <ol style="list-style-type: none"> 1. (A) Angi maskinmodellen. 2. (B) Angi maskinens serienummer fra typeskiltet. 3. (C) Forsikre deg om at korrekt serienummer brukes fra delelisten. 4. Angi delenummer og antall. Bestill ikke ut fra side- eller referansenumre. 5. Angi ditt navn, firmanavn, kunde-ID-nummer, fakturerings- og forsendelsesadresse, telefonnummer og innkjøpsordnummer. 6. Angi detaljerte forsendelsesinstruksjoner. <hr/> <p>(D) ▽ – angir en delegruppe ▲ – angir deler inkludert i en delegruppe</p>	<p>Fyll ut ved installasjonstidspunkt for fremtidig bruk.</p> <p>Modellnr. – _____</p> <p>Serienr. – _____</p> <p>Maskinens tillegg – _____</p> <p>Salgsrep. – _____</p> <p>Salgsrep. telefonnr. – _____</p> <p>Kunde-ID-nummer – _____</p> <p>Installasjonsdato – _____</p>
-----------	---	---

PL	<p>JAK ZAMAWIAĆ CZĘŚCI - patrz schemat powyżej.</p> <p>Należy używać wyłącznie części dostarczanych przez firmę TENNANT Company lub równoważnych. Części i dostawy mogą być zamawiane online, przez telefon, faksem lub pocztą.</p> <p>Aby zapewnić szybką dostawę, należy przestrzegać następujących wskazówek.</p> <ol style="list-style-type: none"> 1. (A) Określić model maszyny. 2. (B) Określić numer seryjny maszyny znajdujący się na tabliczce znamionowej. 3. (C) Odszukać ten numer seryjny w wykazie części. 4. Określić numer części i ilość. Nie zamawiać na podstawie numeru strony lub liczby porządkowej wykazu. 5. Podać swoje nazwisko, nazwę firmy, numer identyfikacyjny klienta, adres dostawy i dostarczenia rachunku, numer telefonu i numer zamówienia zakupu. 6. Podać dokładne instrukcje dotyczące dostawy. <hr/> <p>(D) ▽ – oznacza zespół ▲ – oznacza część w zespole</p>	<p>Prosimy wpisać datę instalacji do późniejszego wykorzystania.</p> <p>Nr modelu – _____</p> <p>Nr seryjny – _____</p> <p>Opcje maszyny – _____</p> <p>Przedst. sprzedaży – _____</p> <p>Nr tel. przedst. sprzed. – _____</p> <p>Nr ident. klienta – _____</p> <p>Data instalacji – _____</p>
-----------	--	---

PT G	<p>COMO ENCOMENDAR PEÇAS – Consulte o diagrama acima.</p> <p>Utilize apenas peças fornecidas pela TENNANT Company ou equivalentes. As peças e consumíveis podem ser encomendados online, por telefone, fax ou correio.</p> <p>Siga os passos abaixo para garantir uma entrega rápida.</p> <ol style="list-style-type: none"> 1. (A) Identifique o modelo da máquina. 2. (B) Identifique o número de série da máquina que se encontra na etiqueta de dados. 3. (C) Certifique-se de que usa o número de série correcto da lista de peças. 4. Identifique o número de produto e a quantidade. Não encomende através de números de página ou de referência. 5. Forneça o seu nome, o nome da empresa, o número de ID do cliente, os endereços de facturação e entrega, o número de telefone e o número da nota de encomenda. 6. Forneça instruções de entrega detalhadas. <hr/> <p>(D) ▽ – identifica uma unidade ▲ – identifica peças incluídas numa unidade</p>	<p>Preencha na altura da instalação para futura referência.</p> <p>Modelo nº – _____</p> <p>Nº de série – _____</p> <p>Opcões da máquina – _____</p> <p>Vendedor – _____</p> <p>Telefone do vendedor – _____</p> <p>Número de ID do cliente – _____</p> <p>Data de instalação – _____</p>
-------------	--	--

RU	<p>КАК ЗАКАЗАТЬ ЗАПЧАСТИ - См. схему ниже.</p> <p>Используйте только запчасти, поставляемые компанией TENNANT или их аналоги. Запасные части и расходные материалы можно заказать в режиме онлайн, телефоном, факсом или электронной почтой.</p> <p>Для своевременной доставки следуйте описанным ниже инструкциям.</p> <ol style="list-style-type: none"> 1. (A) Укажите модель машины. 2. (B) Укажите серийный номер машины, обозначенный на табличке технических данных. 3. (C) Удостоверьтесь, что надлежащий серийный номер перечислен в списке запчастей. 4. Укажите номер детали и нужное количество. Не используйте номера страниц или ссылок. 5. Укажите свое имя, название компании, идентификационный номер покупателя, расчетный адрес и адрес доставки, телефонный номер и номер заказа на покупку. 6. Укажите подробные сведения о доставке. <hr/> <p>(D) ▽ – означает узел ▲ – обозначает деталь узла</p>	<p>Во время установки заполните, пожалуйста, эти сведения для того, чтобы ссылаться в дальнейшем.</p> <p>Модель Э – _____</p> <p>Серийный Э – _____</p> <p>Опции машины – _____</p> <p>Торговый представитель – _____</p> <p>Телефон торгового представителя – _____</p> <p>Идент. номер покупателя – _____</p> <p>Дата установки – _____</p>
-----------	--	--

SE	<p>BESTÄLLNING AV RESERVDELAR – Se ovanstående schema.</p> <p>Använd endast delar från Tennant Company eller likvärdiga. Delar och material kan beställas online, telefoniskt, per fax eller post.</p> <p>Följ nedanstående steg för en snabb leverans.</p> <ol style="list-style-type: none"> (A) Identifiera maskinens modell. (B) Identifiera maskinens serienummer på typskylten. (C) Kontrollera att rätt serienummer används från dellistan. Identifiera artikelnumret och mängden. Beställ inte med hjälp av sido- eller referensnummer. Uppge ditt namn, företagets namn, kundens ID-nummer, faktura- och leveransadress, telefonnummer och ordernumret vid inköp. Ge detaljerade transportanvisningar. 	<p>Fyll i vid installation och spar för framtida bruk.</p> <p>Modellnr. – _____</p> <p>Serienr. – _____</p> <p>Tilvalsutrustning – _____</p> <p>Försäljare – _____</p> <p>Försäljarens tel.nr. – _____</p> <p>Kundnummer – _____</p> <p>Installationsdatum – _____</p>
	<p>(D) ▽ – identifierar en modul ▲ – identifierar delar som ingår i en modul</p>	

SK	<p>POSTUP PRI OBJEDNÁVANÍ ČASTÍ - Pozri vyššie uvedený diagram.</p> <p>Využívajte výhradne dielce dodané spoločnosťou TENNANT, alebo ich ekvivalenty. Dielce a položky je možné objednať online, telefonicky, faxom, alebo poštou.</p> <p>Na zabezpečenie promptného doručenia sa riadte nasledovnými krokmi.</p> <ol style="list-style-type: none"> (A) Identifikujte model stroja. (B) Z etikety s údajmi identifikujte sériové číslo stroja. (C) Ubezpečte sa, že ste zadali správne sériové číslo zo zoznamu dielcov. Identifikujte číslo dielu a množstvo. Neobjednávajte pomocou čísel strán, alebo referenčných čísel. Zadajte Vaše meno, meno spoločnosti, ID číslo zákazníka, fakturačnú a prepravnú adresu, telefónne číslo a objednávacie číslo dielu. Uvedte podrobné prepravné pokyny. 	<p>Vypĺňte prosím pri inštalácii pre prípad potreby v budúcnosti.</p> <p>č. modelu – _____</p> <p>Sériové č. – _____</p> <p>Zvláštne príslušenstvo stroja – _____</p> <p>Obchodné zastúpenie – _____</p> <p>Obch. zastúpenie tel. č. – _____</p> <p>ID č. zákazníka – _____</p> <p>Dátum inštalácie – _____</p>
	<p>(D) ▽ – identifikuje sadu ▲ – identifikuje časti sady</p>	

SL	<p>NAROČANJE NADOMESTNIH DELOV - glejte zgornjo sliko.</p> <p>Uporabljajte samo originalne nadomestne dele Tennant ali enakovredne dele. Dele in potrošni material lahko naročite prek spleta, po telefonu, faksu ali pošti.</p> <p>Za zagotovitev čimbolj hitre dostave sledite spodnjim navodilom.</p> <ol style="list-style-type: none"> (A) Ugotovite model stroja. (B) Na ploščici s podatki poiščite serijsko številko stroja. (C) Poskrbite, da na seznamu nadomestnih delov poiščete pravilno serijsko številko. Poiščite številko dela in potrebno količino. Pri naročilih ne navajajte strani ali referenčne številke. Navedite svoje ime, ime podjetja, ID številko stranke, naslova za dostavo in izdajo računa, telefonsko številko in številko naročila. Navedite podrobna navodila za dostavo. 	<p>Prosimo, da ob vgradnji izpolnite te podatke, da vam bodo v prihodnje na voljo.</p> <p>Št. modela – _____</p> <p>Serijska številka – _____</p> <p>Dodatna oprema stroja – _____</p> <p>Prodajni predstavnik – _____</p> <p>Telefonska št. prodajnega predstavnika – _____</p> <p>Številka stranke – _____</p> <p>Datum vgradnje – _____</p>
	<p>(D) ▽ – označuje sklop ▲ – označuje dele sklopa</p>	

TR	<p>PARÇALARIN SİPARİŞ EDİLMESİ - Yukarıdaki şemaya bakın.</p> <p>Yalnızca TENNANT Company'den sağlanan veya eşdeğerde parçalar kullanın. Parça veya sarf malzemeleri çevrimiçi olarak, telefonla, faksla veya postayla sipariş edilebilir.</p> <p>Zamanında teslimatı sağlamak için aşağıdaki adımları izleyin.</p> <ol style="list-style-type: none"> (A) Makine modelini belirtin. (B) Veri etiketinden makine seri numarasını belirtin. (C) Parça listesinden uygun seri numarasının kullanıldığından emin olun. Parça numarasını ve miktarını belirtin. Sayfa veya referans numaralarını kullanarak sipariş vermeyin. Adınızı, şirketinizin adını, müşteri kimlik numaranızı, faturalama ve sevkiyat adreslerini, telefon numarasını ve satın alma siparişi numarasını belirtin. Ayrıntılı sevkiyat talimatlarını belirtin. 	<p>İleri tarihlerde başvurmak için lütfen kurulum sırasında doldurun.</p> <p>Model No. - _____</p> <p>Seri No. - _____</p> <p>Makine Seçenekleri - _____</p> <p>Satış Temsilcisi - _____</p> <p>Satış Temsilcisi telefon no. - _____</p> <p>Müşteri Kimlik Numarası - _____</p> <p>Kurulum Tarihi - _____</p>
	<p>(D) ▽ – bir tertibatı belirtir ▲ – tertibattaki parçaları belirtir</p>	

GENERAL RECOMMENDED MAINTENANCE

General Recommended Maintenance Items

Ref.	Part No.	Description	Qty.
	390942	Blade, Sqge, Rear, 37.50l Linatex[700mm]	1
	390922	Blade, Sqge, Rear, 44.00l Linatex[800mm]	1
▽	391384	Squeegee Kit, 700mm, Ure	1
▲	391377	Blade, Sqge, Front, 35.00l Ure [700mm]	1
▲	391378	Blade, Sqge, Rear, 37.50l Pyu [700mm]	1
▽	391386	Squeegee Kit, 700mm, Gum	1
▲	390943	Blade, Sqge, Front, 35.00l [Linx, 700mm]	1
▲	390936	Blade, Sqge, Rear, 37.50l Gum [700mm]	1
▽	391383	Squeegee Kit, 800mm, Ure	1
▲	391379	Blade, Sqge, Front, 41.50l Ure [800mm]	1
▲	391380	Blade, Sqge, Rear, 44.0l Pyu [800mm]	1
▽	391385	Squeegee Kit, 800mm, Gum	1
▲	390923	Blade, Sqge, Front, 41.50l [Linx, 800mm]	1
▲	390934	Blade, Sqge, Rear, 44.00l Gum [800mm]	1
	86859	Squeegee Assy, Side [Linatex] (Disk Head – Standard)	2
	1058731	Squeegee Assy, Side, Disc, Ure (Disk Head – Optional)	2
	1058729	Squeegee Assy, Side, Disc, Gum (Disk Head – Optional)	2
	391334	Squeegee Assy, Side [Linatex] (Cyld Head – Standard)	2
	1058728	Squeegee Assy, Cylrcl, Ure [T7/Ssr] (Cyld Head – Optional)	2
	1058715	Squeegee Assy, Cylrcl, Gum [T7/Ssr] (Cyld Head – Optional)	2
	1073476	Caster, Swivel, 50mmd, M10 X 30, Clr Pl	2
	1013531	Skirt, Spray, 650mm	1
	1011376	Skirt, Spray, 800mm	1
	1010560	Wheel, Bmpr, 80d X 25w, Non-Marking	1
	1013611	Seal, Cover, Recvy	1
	1020719	Seal, Afmkt, Bulb, Clsd Cell, Adh, 8ft	1
	1020727	Seal, Afmkt, Bulb, Clsd Cell, Adh, 8ft	1
	1020301	Seal, Afmkt, Bulb, Clsd Cell, Adh, 8ft	1
	1207882	Hose, Vacuum, 1.50id X 057.1l, 2cuff, Pu	1
	1037821	Filter, Panl, Dust, 2.3 X 04.5 X 06.4	1
	1016392	Gasket, Fltr, Tank	1
▽	1014274	Hose Assy, Drain, 1.50id X 27.8l, Blk (Recovery Tank)	1
▲▽	1008639	Cap, Drain Assy	1
▲▲	1019563	Strap, Drain Cap	1
▲▲	1008637	O Ring, 1.48" Id, 1.76" Od	1
▽	1014268	Hose Assy, Drain, 1.50id X 27.0l, Blk (Solution Tank)	1
▲▽	1008639	Cap, Drain Assy	1
▲▲	1019563	Strap, Drain Cap	1
▲▲	1008637	O Ring, 1.48" Id, 1.76" Od	1
▽	1011402	Switch, Key	1
▲	1017696	Key Set, Replmt [F/ Keyswitch 1011402]	1

GENERAL RECOMMENDED MAINTENANCE

General Recommended Maintenance Items

Ref.	Part No.	Description	Qty.
▽	9007970	① Module Kit, Replmt [Ec-H2o]	1
▲▽	9006324	① Ec-H2o Kit, Module B, Plumbing	1
▲▲	1062006	① Electrode, Cylindrical	1
▲▲	1013236	① Valve, Shutoff, Ele, 24vdc	1
▲▲	1057637	① Electrode, 5 Plate, High Flow (Replaced By 1233516)	1
▲▲	1044393	① Switch, Rocker, Spst, Mom	1
▲	1054776	① Grommet, Blind	1
▲	9007969	① Controller Kit, Replmt [Ec-H2o] (Replaced By 9020642)	1
	1030592	Seal, Afmkt, Bulb, 90, 0.75d F/11ga 03ft	1
	1052726	① Alarm, 9-48vdc, 95 Db(A) [Ec-H2O]	1
▽	9021553	⑤ Module Kit, Replmt [Ec-H2o, B 02] (Includes ec-H2O NanoClean Cartridge)	1
▽	9020643	④ Module Kit, Replmt [Ec-H2o, B 02] (Includes ec-H2O NanoClean Cartridge) (Replaced By 9021553)	1
▽	9011810	③ Module Kit, Replmt [Ec-H2o, B 02] (Includes ec-H2O NanoClean Cartridge) (Replaced By 9021553)	1
▲▽	9014126	② Ec-H2o Nc Kit [Module B, Plumbing]	1
▲▲	1044393	② Switch, Rocker, Spst, Mom	1
▲▲	1233516	④ Electrode, 5 Plate [De Nora Tech]	1
▲▲	1208164	③ Electrode, 5 Plate, High Flow (Replaced By 1233516)	1
▲▲	1073286	② Harness, Ele, Module B2 [Ec-H2o]	1
▲	9020642	④ Controller Kit, Replmt [Ec-H2o Nc]	1
▲	9014127	③ Controller Kit, Replmt [Ec-H2o Nc] (Includes ec-H2O NanoClean Cartridge) (Replaced By 9020642)	1
	9013646	② Cartridge, Ec-H2o Nanoclean Wcm, 270ml	1
	9010086	② Control Box Assy Kit, Replmt, Telem[Intl]	1
	1247522	Antenna, Telem [4g, 72"]	1
	1070659	Antenna, Telem, 70 In [Gprs] (Replaced By 1247522)	1

① Serial number (10000-10999)

② Serial number (11000-)

③ Serial number (11000-16185)

④ Serial number (16186-AUG2022)

⑤ Serial number (SEP2022-)

SECTION 2

Contents	Page	Contents	Page
Fig. 1 – Replacement Brushes, Cylindrical	2-2	Fig. 25 – Solution Tank Group, Disk Scrub Head	2-50
Fig. 2 – Replacement Brushes And Pad Drivers, 650 mm	2-4	Fig. 26 – Solution Tank Group, Cylindrical Scrub Head	2-52
Fig. 3 – Replacement Brushes And Pad Drivers, 800 mm	2-6	Fig. 27 – Tanks Drain Group	2-54
Fig. 4 – Main Frame Group, Disk Scrub Head	2-8	Fig. 28 – Rear Squeegee Lift Group, Disk Scrub Head	2-56
Fig. 5 – Main Frame Group, Cylindrical Scrub Head, 800 mm	2-10	Fig. 29 – Rear Squeegee Lift Group, Cylindrical Scrub Head	2-58
Fig. 6 – Seat Group (S/N 18318–)	2-12	Fig. 30 – Rear Squeegee Group, 650 mm	2-60
Fig. 7 – Seat Group (S/N 00001–18318)	2-14	Fig. 31 – Rear Squeegee Group, 800 mm	2-62
Fig. 8 – Steering Group	2-16	Fig. 32 – Circuit Board Group	2-64
Fig. 9 – Instrument Panel Group	2-18	Fig. 33 – Electrical Group	2-66
Fig. 10 – Front Drive Wheel Group	2-20	Fig. 34 – Electrical Schematic, Standard, FaST & ec-H2O Models (S/N 12695–)	2-68
Fig. 11 – Brake Pedal and Accelerator Pedal Group	2-22	Fig. 35 – Electrical Schematic, Standard, FaST & ec-H2O Models (S/N 11000–12694)	2-72
Fig. 12 – Disk Scrub Head Lift Group	2-24	Fig. 36 – Electrical Schematic, Standard & FaST Model (S/N 10000–10999)	2-76
Fig. 13 – Disk Scrub Head Drive Motor Group, 650 mm	2-26	Fig. 37 – Electrical Schematic, ec-H2O Model (S/N 10000–10999)	2-78
Fig. 14 – Disk Scrub Head Drive Motor Group, 800 mm	2-28	Fig. 38 – Wire Harnesses Group, Main (S/N 15418–)	2-80
Fig. 15 – Disk Scrub Head Side Squeegee Group, Right	2-30	Fig. 39 – Wire Harnesses Group, Main (S/N 10000–15417)	2-83
Fig. 16 – Disk Scrub Head Side Squeegee Group, Left	2-32	Fig. 40 – Wire Harnesses Group, Tank	2-86
Fig. 17 – Cylindrical Scrub Head Lift Group	2-34	Fig. 41 – Wire Harnesses Group, ec-H2O NanoClean (S/N 11000–)	2-87
Fig. 18 – Cylindrical Scrub Head Group, 700 mm	2-36	Fig. 42 – Wire Harnesses Group, ec-H2O (S/N 10000–10999)	2-88
Fig. 19 – Cylindrical Scrub Head Group, 800 mm	2-38	Fig. 43 – Wire Harnesses Group, ec-H2O NanoClean Main Control Board (S/N 11000–)	2-89
Fig. 20 – Cylindrical Scrub Head Drive Group, Right Side	2-40	Fig. 44 – Wire Harnesses Group, ec-H2O Main Control Board (S/N 10000–10999)	2-90
Fig. 21 – Cylindrical Scrub Head Drive Group, Left Side	2-42	Fig. 45 – Wire Harnesses Group, Iris Telemetry	2-91
Fig. 22 – Cylindrical Scrub Head Squeegee Group	2-44	Fig. 46 – Cable Assembly, Iris Telemetry	2-93
Fig. 23 – Recovery Tank Group	2-46	Fig. 47 – Label Group	2-94
Fig. 24 – Vacuum Fan Group	2-48		

Fig. 1 – Replacement Brushes, Cylindrical

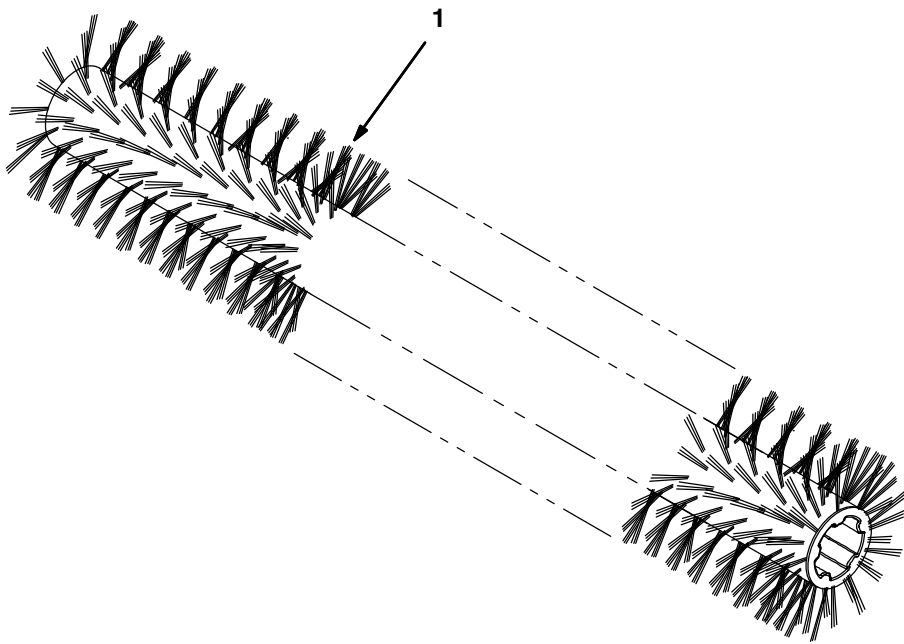

Fig. 1 – Replacement Brushes, Cylindrical

Ref.	Part No.	Description	Qty.
1	222305	Brush, Scb, 28l, 18sr, Nyl, Spl	2
1	222306	Brush, Scb, 28l, 18sr, Abr, Spl	2
1	222304	Brush, Scb, 28l, 18sr, Pyp, Spl	2
1	374041	Brush, Scb, 28l, 18sr, Hd Pyp, Spl	2
1	222308	Brush, Scb, 32l, 18sr, Nyl, Spl	2
1	222309	Brush, Scb, 32l, 18sr, Abr, Spl	2
1	222307	Brush, Scb, 32l, 18sr, Pyp, Spl [Grout]	2
1	374042	Brush, Scb, 32l, 18sr, Hd Pyp, Spl	2

Fig. 2 – Replacement Brushes And Pad Drivers, 650 mm

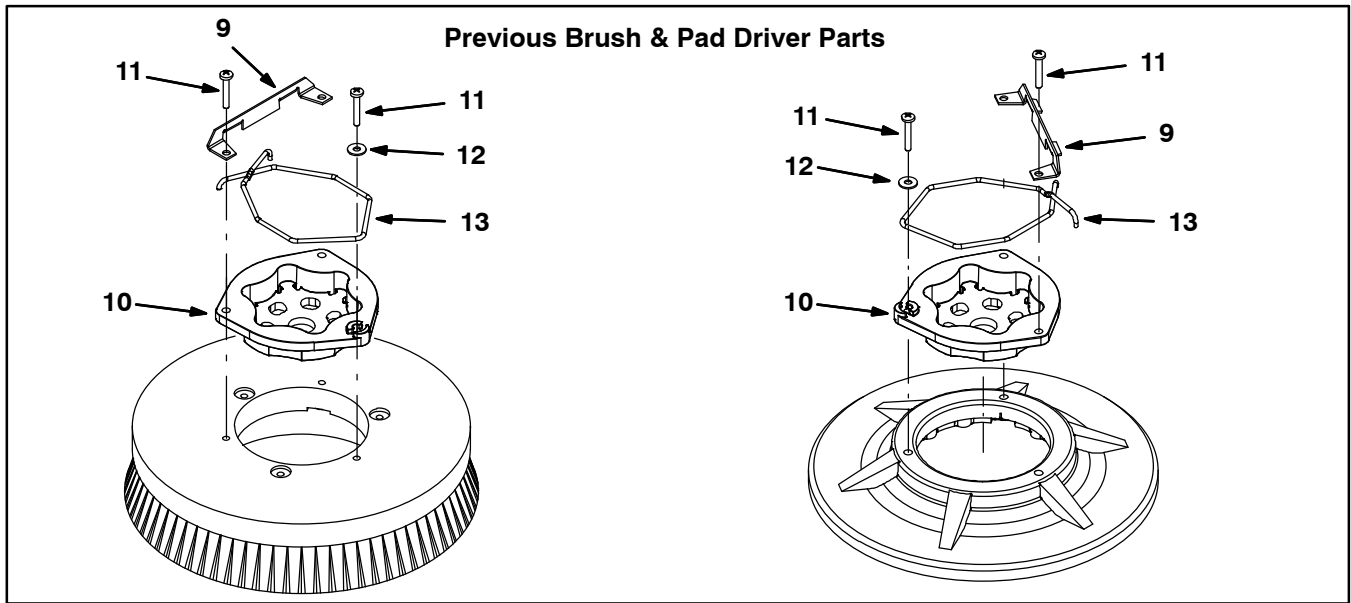
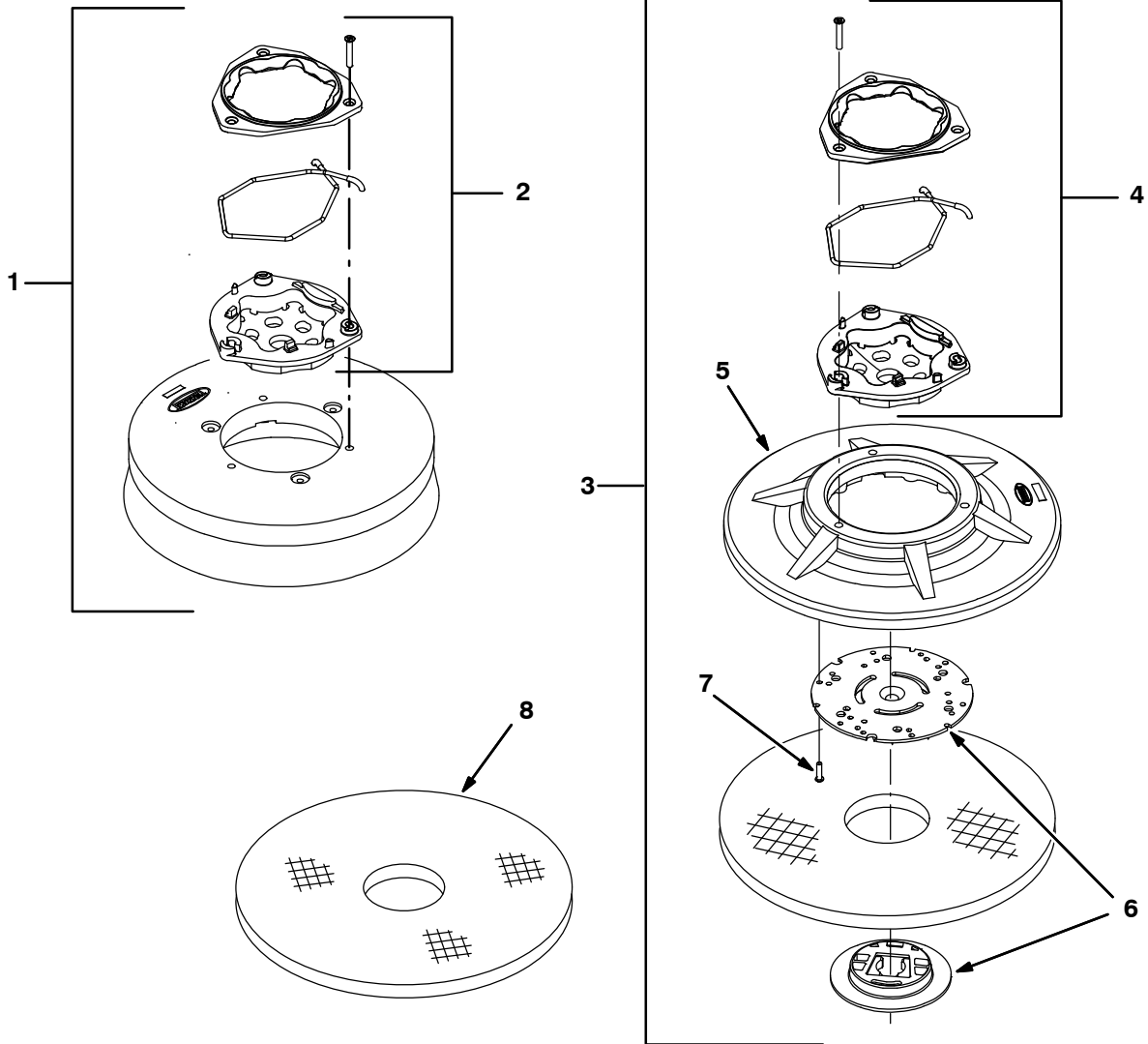

Fig. 2 – Replacement Brushes And Pad Drivers, 650 mm

	Ref.	Part No.	Description	Qty.
▽	1	1220226	Brush Assy, Disk, Scb, 13.0d, Nyl	2
▲	2	9014664	Brush Kit, Hub Assy, Drive, Ci [Hdpe]	1
▽	1	1223608	Brush Assy, Disk, Scb, 13.0d, Pyp [Tnv]	2
▲	2	9014664	Brush Kit, Hub Assy, Drive, Ci [Hdpe]	1
▽	1	1223611	Brush Assy, Disk, Scb, 13.0d, Sab [Tnv]	2
▲	2	9014664	Brush Kit, Hub Assy, Drive, Ci [Hdpe]	1
▽	3	1223610	Driver Assy, Pad, 13.0d [Tnv]	2
▲	4	9014664	Brush Kit, Hub Assy, Drive, Ci [Hdpe]	1
▲	5	N/A	Disk, Driver, Pad, W/ Face, 13.0d	1
▲	6	370095	Device, Centering, Clip On, TI [Gf Pp]	1
▲	7	360943	Screw, Pan, Phl, 10–14 X 0.75, F/ Plstc	3
	8	89046	Pad, Stripping, 13.0d, Brown[1pick=1pad]	2
	8	89047	Pad, Scb, 13.0d, Blu	2
	8	89048	Pad, Buff, 13.0d, Red [1pick=1pad]	2
	8	89049	Pad, Polish, 13.0d, White [1pick=1pad]	2
	8	1051024	Pad, Surf Prep, 13.0d [Mar, 1pick=1pad]	2

Previous Brush And Pad Driver Parts

	Ref.	Part No.	Description	Qty.
	9	24299	Bracket, Retainer, Spring	1
	10	1017368	Hub, Drive, Brush, Disk, 3hole 5.8bc	1
	11	32746	Screw, Pan, M6 X 1.0 X 35, Ss	3
	12	01684	Washer, Flat, 0.25 Ss	1
	13	1017957	Spring, Retaining, Brush	1
		1018377	Brush Assy, Disk, Scb, 13.0 D, Soft Nylon (Replaced By 1220226)	2
		1014346	Brush Assy, Disk, Scb, 13.0d, Pyp (Replaced By 1223608)	2
		1018457	Brush Assy, Disk, Scb, 13.0 D, Super Abrasive (Replaced By 1223611)	2
		379013	Driver Assy, Pad, 13.0d (Replaced By 1223610)	2

Fig. 3 – Replacement Brushes And Pad Drivers, 800 mm

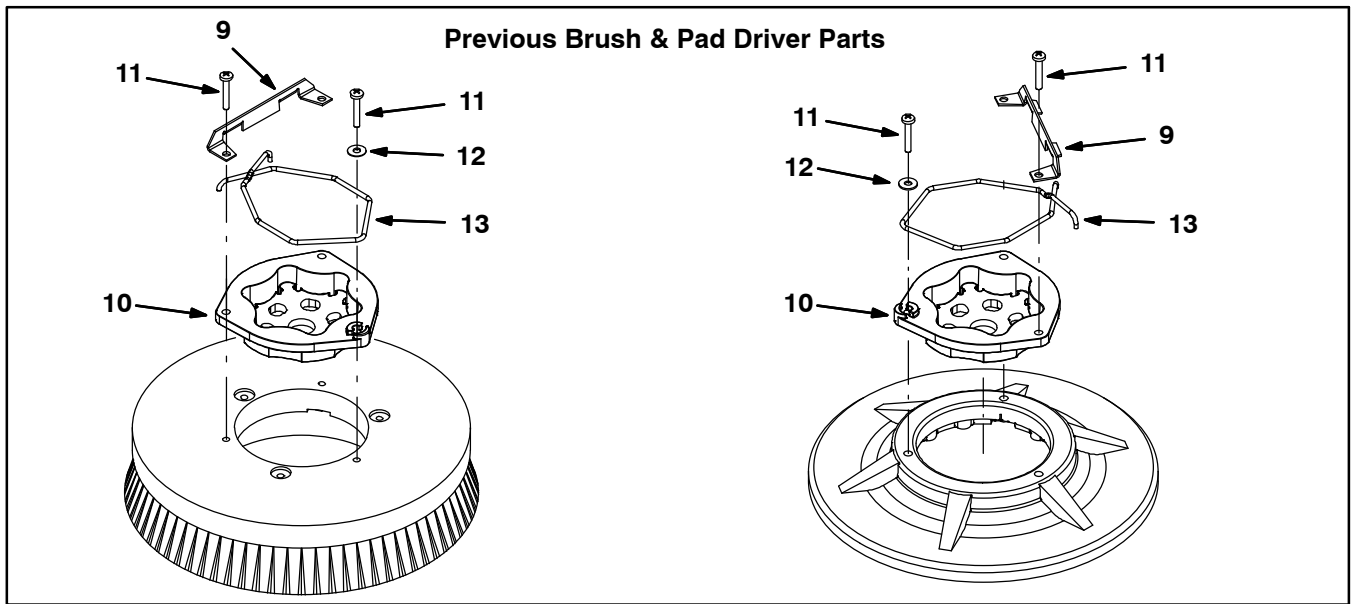
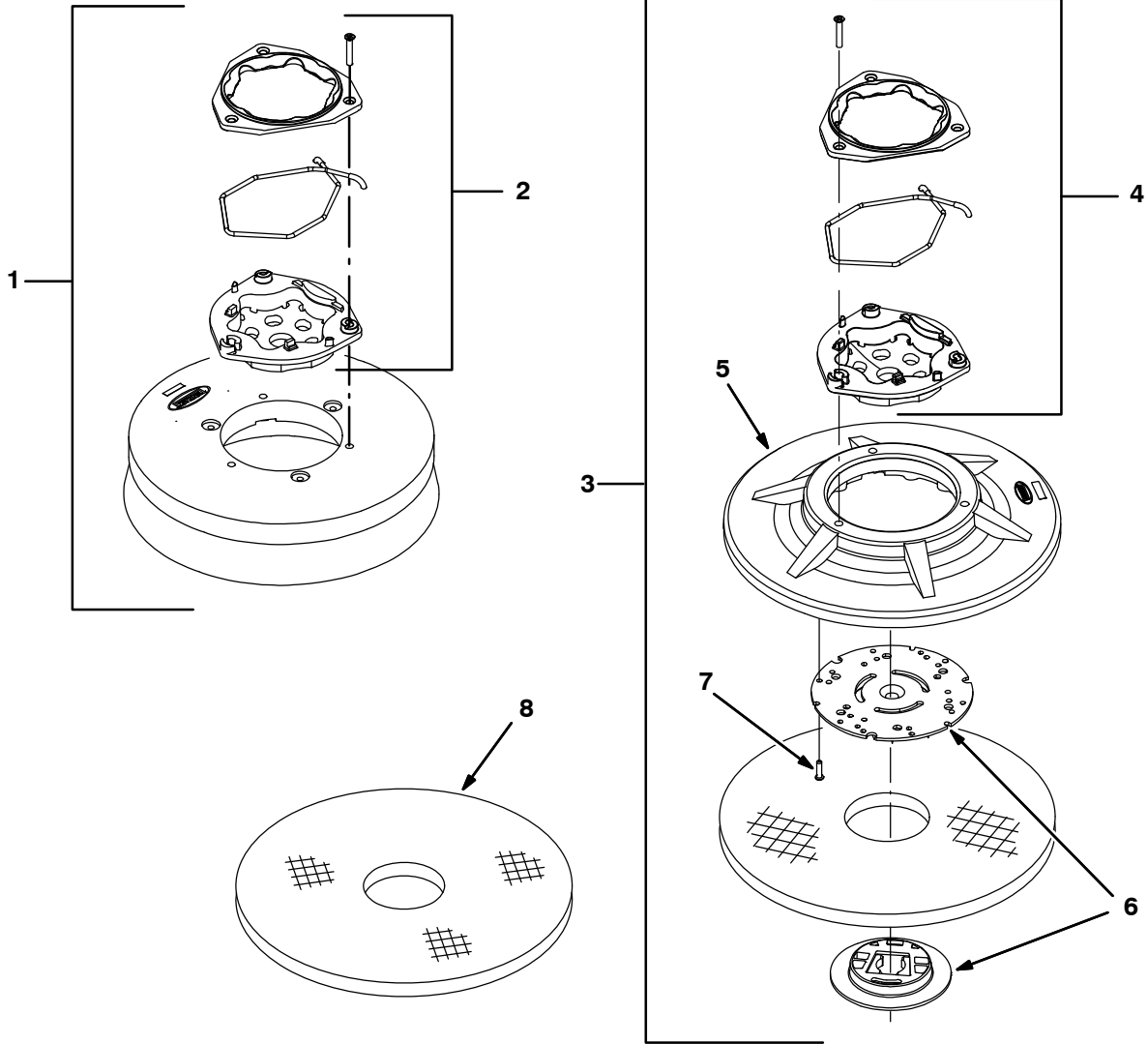

Fig. 3 – Replacement Brushes And Pad Drivers, 800 mm

	Ref.	Part No.	Description	Qty.
▽	1	1223626	Brush Assy, Disk, Scb, 16.0d, Nyl [Tnv]	2
▲	2	9014664	Brush Kit, Hub Assy, Drive, Ci [Hdpe]	1
▽	1	1223624	Brush Assy, Disk, Scb, 16.0d, Pyp [Tnv]	2
▲	2	9014664	Brush Kit, Hub Assy, Drive, Ci [Hdpe]	1
▽	1	1223625	Brush Assy, Disk, Scb, 16.0d, Sab [Tnv]	2
▲	2	9014664	Brush Kit, Hub Assy, Drive, Ci [Hdpe]	1
▽	3	1220244	Driver Assy, Pad, 16.0d	2
▲	4	9014664	Brush Kit, Hub Assy, Drive, Ci [Hdpe]	1
▲	5	N/A	Disk, Driver, Pad, W/ Face, 16.0d	1
▲	6	370095	Device, Centering, Clip On, TI [Gf Pp]	1
▲	7	360943	Screw, Pan, Phl, 10–14 X 0.75, F/ Plstc	3
	8	370092	Pad, Stripping, 16.0d, Blk [Hi Prod]	2
	8	63248–1	Pad, Stripping, 16.0d, Brown[1pick=1pad]	2
	8	63248–2	Pad, Scb, 16.0d, Blu [1pick=1pad]	2
	8	63248–3	Pad, Buff, 16.0d, Red [1pick=1pad]	2
	8	1051027	Pad, Surf Prep, 16.0d [Mar, 1pick=1pad]	2
	8	63248–4	Pad, Polish, 16.0d, White [1pick=1pad]	2

Previous Brush And Pad Driver Parts

	Ref.	Part No.	Description	Qty.
	9	24299	Bracket, Retainer, Spring	1
	10	1017368	Hub, Drive, Brush, Disk, 3hole 5.8bc	1
	11	32746	Screw, Pan, M6 X 1.0 X 35, Ss	3
	12	01684	Washer, Flat, 0.25 Ss	1
	13	1017957	Spring, Retaining, Brush	1
		1016634	Brush Assy, Disk, Scb, 16.0 D, Soft Nylon (Replaced By 1223626)	2
		1016633	Brush Assy, Disk, Scb, 16.0 D, Polypropylene (Replaced By 1223624)	2
		1018455	Brush Assy, Disk, Scb, 16.0 D, Super Abrasive (Replaced By 1223625)	2
		379016	Driver Assy, Pad, 16.0d (Replaced By 1220244)	2

Fig. 4 – Main Frame Group, Disk Scrub Head

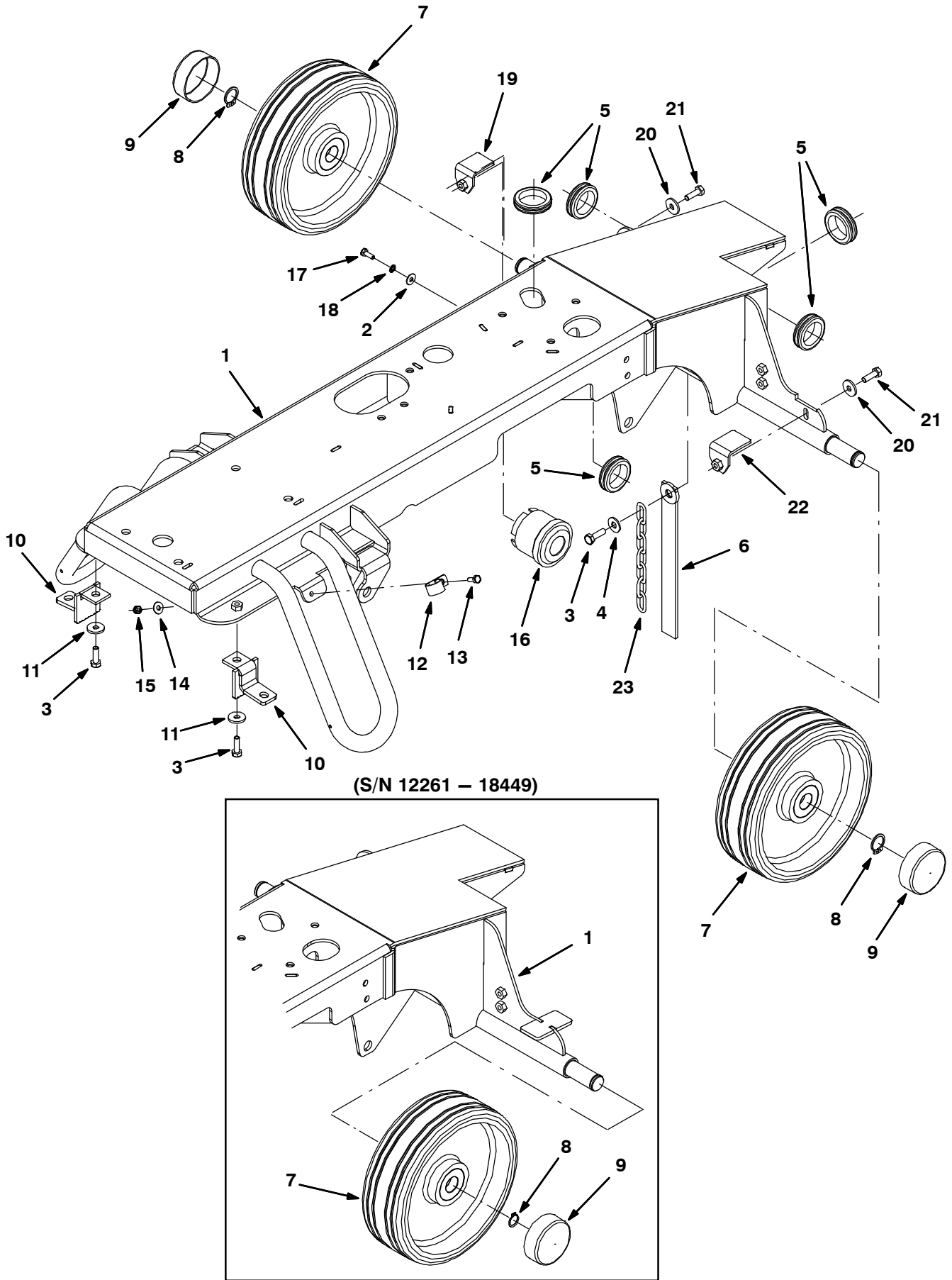

Fig. 4 – Main Frame Group, Disk Scrub Head

Ref.	Part No.	Description	Qty.
1	1077223	④ Frame Wldt, Main, Disk [T7 Eu]	1
1	1075255	③ Frame Wldt, Main, Disk [T7 Eu] (Replaced By 1077223 & Qty 2 of 1257594)	1
1	1054028	③ Frame Wldt, Main, Disk [T7] (Replaced By 1259538 & Qty 2 of 1257594)	1
2	01684	Washer, Flat, 0.25 Ss	2
3	09010	Screw, Hex, M8 X 1.25 X 25, Ss	3
4	01685	Washer, Flat, 0.31 Ss	1
5	10632-13	Grommet, Rbr, 1.50id, F/ 1.8h, .19matl	5
6	1014318	Strap, Static	1
7	1038560	Tire Assy, Solid, 250mmx80mm, 25mm Id	2
7	1064376	Tire Assy, Solid, 250mm X 80, 25mmid,Pyu	2
8	1257594	④ Ring, Retaining, Shaft, Ext, 25mmd, Hd	2
8	09005	③ Ring, Retaining, Ext, 1.00D, Basic (For Use With Frame's 1054028 & 1075255)	2
9	1016957	Cap, Vyl, 70mm Id X 25mm L	2
10	1017688	Bracket Wldt, Stand, Jack	2
11	1017218	Washer, Flat, 0.321b 1.00d .12, Ss	2
12	140300	Clamp, Cable, Stl, 0.50d [Insulated]	1
13	08716	Screw, Hex, M6 X 1.0 X 20, Ss	1
14	01684	Washer, Flat, 0.25 Ss	1
15	08712	Nut, Hex, Lock, M6 X 1.0, Ss, NI	1
16	1018505	Horn, 12-48vdc	1
17	15678	Screw, Hex, M6 X 1.0 X 16, Ss	1
18	07515	Washer, Lock, Int, .25, Ss	1
19	1075252	② Tank, Mount, Bracket	1
20	1017218	② Washer, Flat, 0.32b 1.00d .12, Ss	2
21	12333	② Screw, Hex, M8 X 1.25 X 25, Ss, NI	2
22	1075258	② Bracket, Mount, Tank [Disk]	1
23	43500	Chain, Coil, Str, #2/0, 09.0l 07 Link	1

① Serial number (00001-12260)

② Serial number (12261-)

③ Serial number (00001-18449)

④ Serial number (18450-)

STANDARD PARTS

Fig. 5 - Main Frame Group, Cylindrical Scrub Head, 800 mm

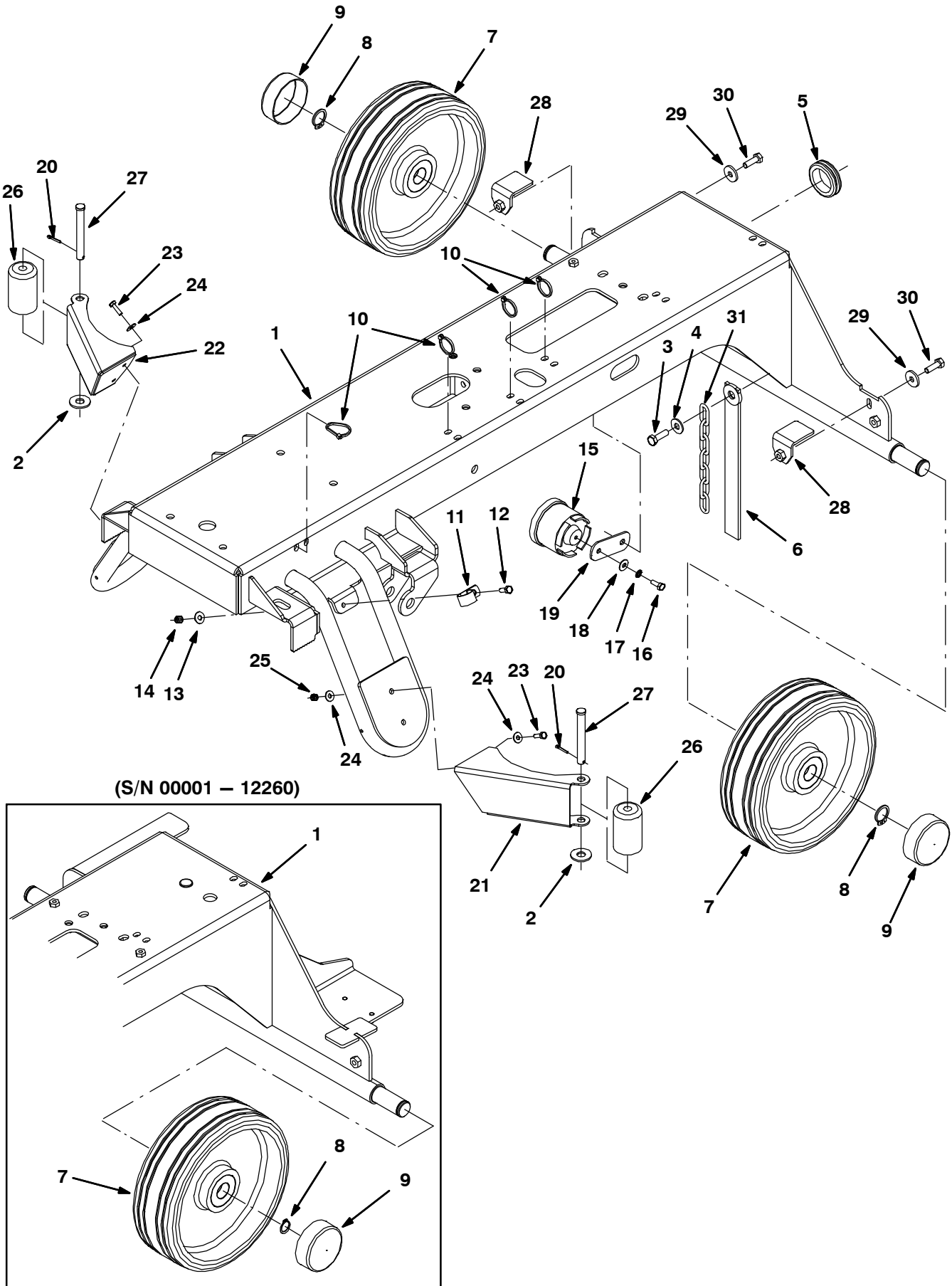

Fig. 5 – Main Frame Group, Cylindrical Scrub Head, 800 mm

Ref.	Part No.	Description	Qty.
1	1077219	④ Frame Wldt, Main, Cyl, 80cm [T7 Eu]	1
1	1075250	③ Frame Wldt, Main, Cyl, 80cm [T7 Eu] (Replaced By 1077219 & Qty 2 of 1257594)	1
1	1056133	① Frame Wldt, Main, 80cm [R14, T7 Cyl] (Replaced By 1077218 & Qty 2 of 1257594)	1
2	41619	Washer, Flat, 0.56b 1.38d .11, Ss	2
3	09011	Screw, Hex, M8 X 1.25 X 30, Ss	1
4	01685	Washer, Flat, 0.31 Ss	1
5	10632-13	Grommet, Rbr, 1.50id, F/ 1.8h, .19matl	1
6	1014318	Strap, Static, 10.3l [Afmkt, 71579]	1
7	1038560	Tire Assy, Solid, 250mmx80mm, 25mm Id	2
7	1064376	Tire Assy, Solid, 250mm X 80, 25mmid,Pyu	2
8	1257594	④ Ring, Retaining, Shaft, Ext, 25mmd, Hd	2
8	09005	③ Ring, Retaining, Ext, 1.00D, Basic (For Use With Frame's 1056133 & 1075250)	2
9	1016957	Cap, Vyl, 70mm Id X 25mm L	2
10	49263	Tie, Cable, Nyl, 11.4l .19w 3.0 Max D	4
11	140300	Clamp, Cable, Stl, 0.50d [Insulated]	1
12	08716	Screw, Hex, M6 X 1.0 X 20, Ss	1
13	01684	Washer, Flat, 0.25 Ss	1
14	08712	Nut, Hex, Lock, M6 X 1.0, Ss, NI	1
15	1018505	Horn, 12-48vdc	1
16	15678	Screw, Hex, M6 X 1.0 X 16, Ss	1
17	07515	Washer, Lock, Int, .25, Ss	1
18	01684	Washer, Flat, 0.25 Ss	2
19	1025354	Plate, Mtg, Horn	1
20	08346	Pin, Cotter, .125 X 0.75	2
21	1033355	Bracket, Guard, Lh (800cyl. Scrubhead)	1
22	1032971	Bracket, Guard, Rh (800cyl. Scrubhead)	1
23	08716	Screw, Hex, M6 X 1.0 X 20, Ss	4
24	01684	Washer, Flat, 0.25, Ss	8
25	08712	Nut, Hex, Lock, M6 X 1.00, Ss, NI	4
26	222178	Roller, Pyu, 1.88d 0.53b 3.05l (800cyl. Scrubhead)	2
27	51528	Pin, Clevis, 0.50d X 4.00l	2
28	1075252	② Tank, Mount, Bracket	2
29	1017218	② Washer, Flat, 0.32b 1.00d .12, Ss	2
30	12333	② Screw, Hex, M8 X 1.25 X 25, Ss, NI	2
31	43500	Chain, Coil, Str, #2/0, 09.0l 07 Link	1

① Serial number (00001-12260)

② Serial number (12261-)

③ Serial number (00001-18217)

④ Serial number (18218-)

Fig. 6 - Seat Group (S/N 18318-)

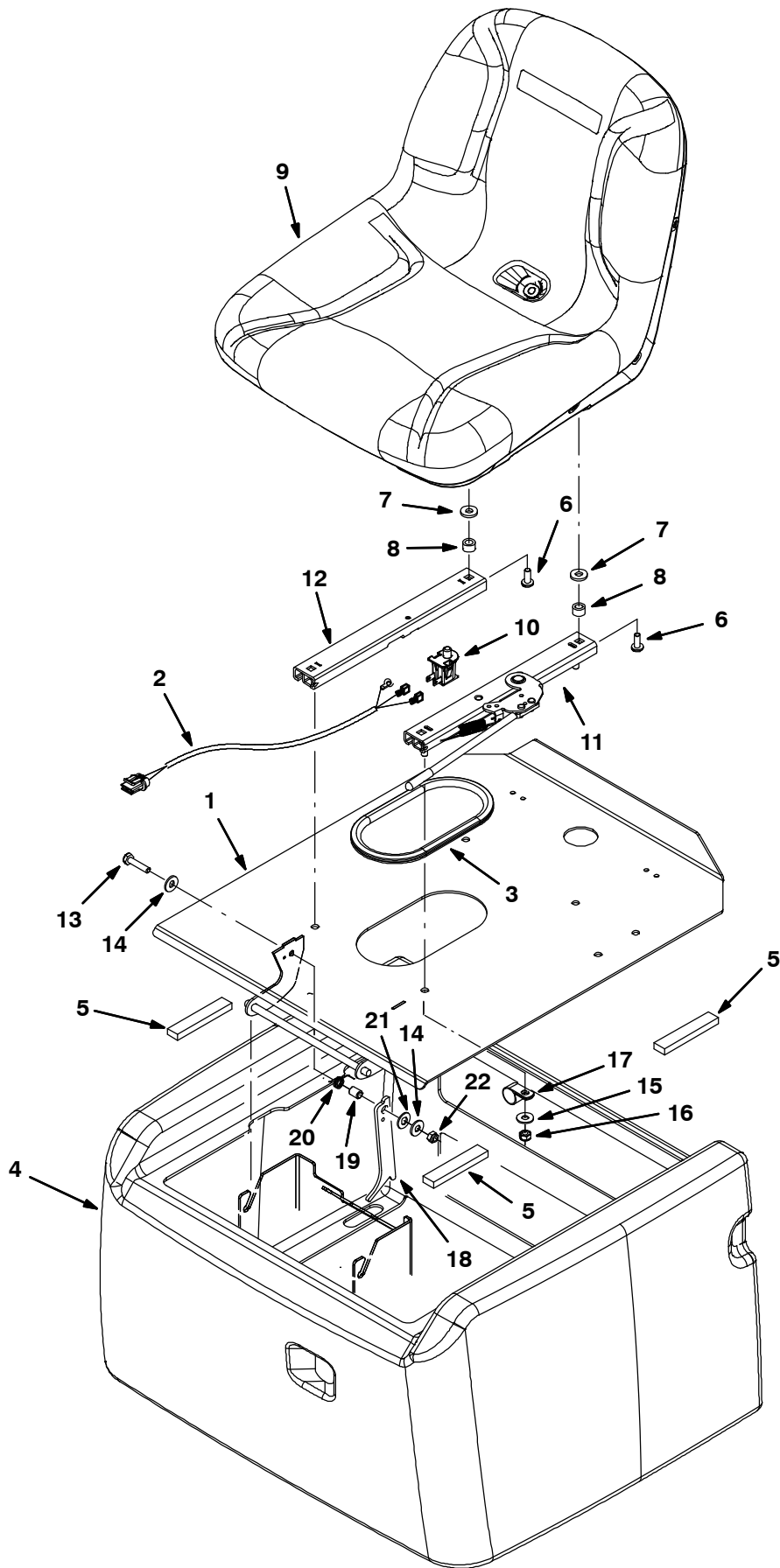

Fig. 6 – Seat Group (S/N 18318–)

Ref.	Part No.	Description	Qty.
1	1017798	Plate Wldt, Seat	1
2	391951	Harness, Seat, [T7/Ssr]	1
3	1020170	Molding, Afmkt, Trim, Pvc, .08–.11, 2ft	1
4	9018603	² Cover, Box, Battery, TI, Afmkt	1
5	1046428	Seal, Afmkt, Rbr, Clsd, Adh, 02ft (ec-H2O Model)	1
6	76956	Screw, Hex, .31–18 X 1.25, G5	4
7	69461	Washer, Flat, 0.38b 0.88d .12, Stl, Pl	4
8	1051052	Spacer, Rnd, .38b .88d .38l	4
9	9005082	Seat Kit, Std, Replmt (Kit Includes Screw 76956 and Spacer 1051052)	1
10	1048955	Switch, Seat, No [Delta 6440–04]	1
11	1077071	Track, Locking, 12.5l, No Stud W/Handle	1
12	1077067	Track, N–Lkg, Seat, 12.5l, No Stud	1
13	09023	Screw, Hex, M8 X 1.25 X 35, Ss, Fl	1
14	01685	Washer, Flat, 0.31 Ss	2
15	32491	Washer, Flat, 0.31 Std	4
16	01760	Nut, Hex, Lock, .31–18, NI, Thin	4
17	46236	Clamp, Cable, Stl, 0.25d X 0.56w, 1h	1
18	1016000	Plate, Stop, Seat, Yellow	1
19	1017699	Sleeve, P/M, 0.437d 0.318b 0.57l 430ss	1
20	10928	Spring, Tors, 0.49id .05wir 05.0coil	1
21	1018151	Washer, Flat, 0.44b 0.88d .06, Nyl	1
22	08713	Nut, Hex, Lock, M8 X 1.25, NI, Ss	1

² Serial number (18318–)

Fig. 7 - Seat Group (S/N 10000-18317)

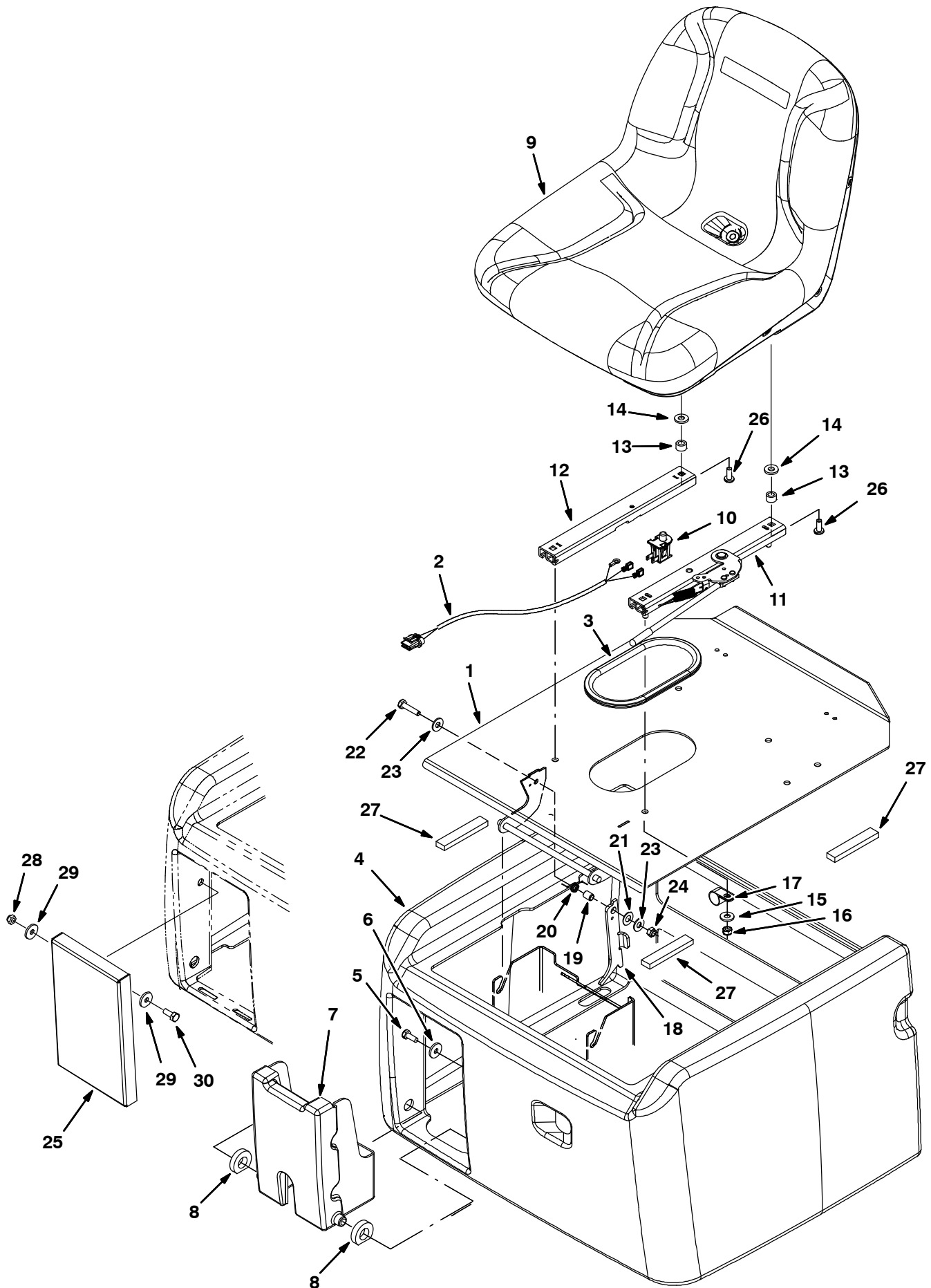

Fig. 7 – Seat Group (S/N 10000–18317)

Ref.	Part No.	Description	Qty.
1	1017798	Plate Wldt, Seat	1
2	391951	Harness, Seat, [T7/Ssr]	1
3	1020170	Molding, Afmkt, Trim, Pvc, .08-.11, 2ft	1
4	1052882	① Cover, Box, Battery, Trimmed, TI[T7] (Fast Models)	1
5	09740	① Screw, Hex, M8 X 1.25 X 20, Ss (Fast Models)	2
6	1017218	① Washer, Flat, 0.321b 1.00d .12, Ss (Fast Models)	2
7	1012087	① Housing, Holder, Trimmed [Fast, Teal] (Fast Models)	1
8	1016553	① Seal, Rbr (Fast Models)	2
9	9005082	Seat Kit, Std, Replmt (Kit Includes Screw 76956 and Spacer 1051052)	1
10	1048955	Switch, Seat, No [Delta 6440–04]	1
11	1077071	Track, Locking, 12.5l, No Stud W/Handle	1
11	1074205	Rail,Adj,Slide,Seat,11.5l,W/Latch,Yellow (Replaced By 1077071)	1
12	1077067	Track, N–Lkg, Seat, 12.5l, No Stud	1
12	1017053	Rail, Adj, Slide, Seat, 11.5l (Replaced By 1077067)	1
13	1051052	Spacer, Rnd, .38b .88d .38l	4
14	69461	Washer, Flat, 0.38b 0.88d .12, Stl, Pl	4
15	32491	Washer, Flat, 0.31 Std	4
16	01760	Nut, Hex, Lock, .31–18, NI, Thin	4
17	46236	Clamp, Cable, Stl, 0.25d X 0.56w, 1h	1
18	1016000	Plate, Stop, Seat, Yellow	1
19	1017699	Sleeve, P/M, 0.437d 0.318b 0.57l 430ss	1
20	10928	Spring, Tors, 0.49id .05wir 05.0coil	1
21	1018151	Washer, Flat, 0.44b 0.88d .06, Nyl	1
22	09023	Screw, Hex, M8 X 1.25 X 35, Ss, Fl	1
23	01685	Washer, Flat, 0.31 Ss	2
24	08713	Nut, Hex, Lock, M8 X 1.25, NI, Ss	1
25	1051138	① Bracket, Cover, Fast Open [T7 Ec–H2o] (Standard & ec–H2O Models)	1
26	76956	Screw, Hex, .31–18 X 1.25, G5	4
27	1046428	Seal, Afmkt, Rbr, Clsd, Adh, 02ft (ec–H2O Model)	1
28	08713	① Nut, Hex, Lock, M8 X 1.25, NI, Ss (Standard & ec–H2O Models)	2
29	1017218	① Washer, Flat, 0.32b 1.00d .12, Ss (Standard & ec–H2O Models)	4
30	09740	① Screw, Hex, M8 X 1.25 X 20, Ss (Standard & ec–H2O Models)	2

① Serial number (10000–18317)

Fig. 8 - Steering Group

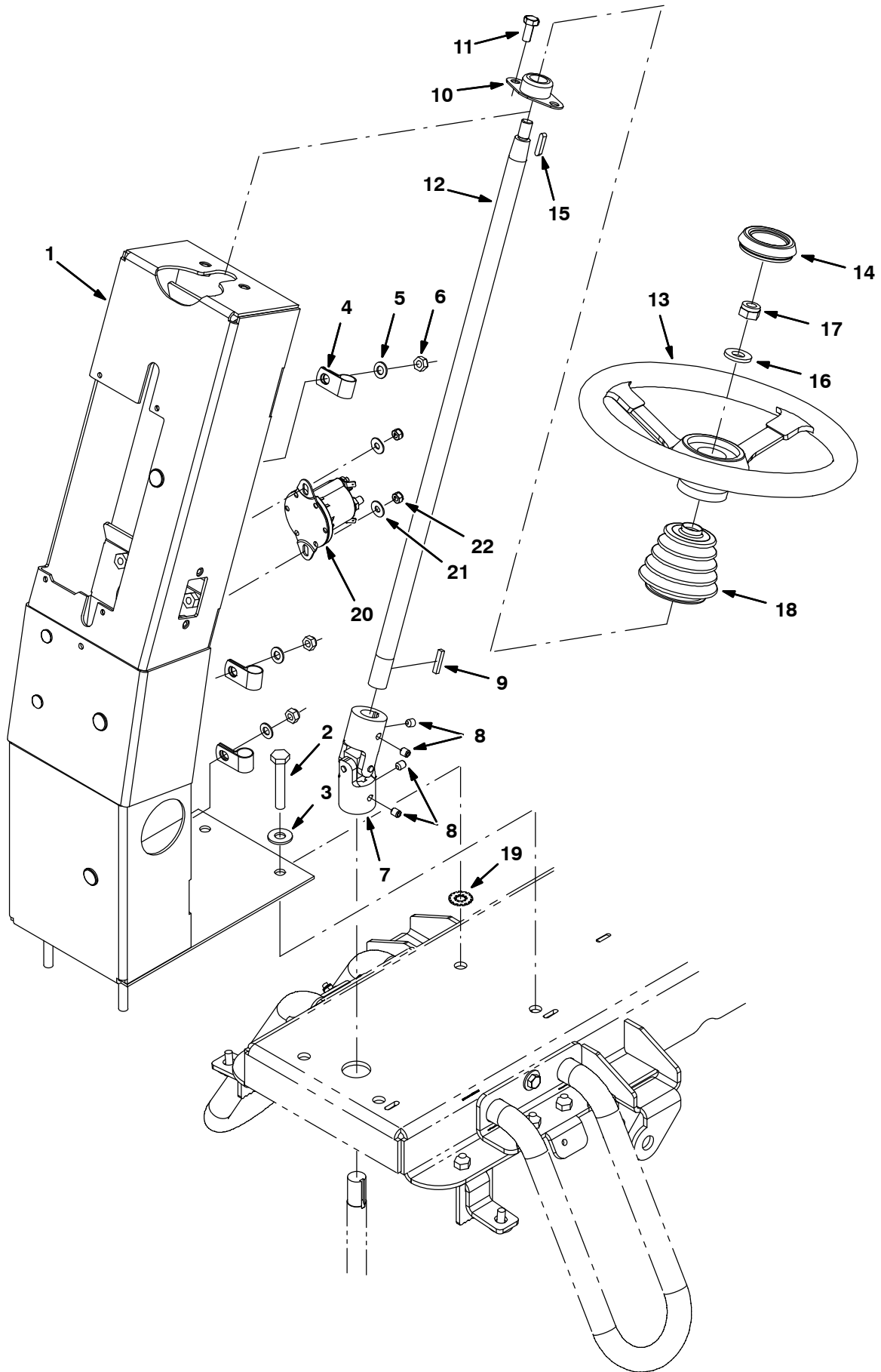

Fig. 8 – Steering Group

Ref.	Part No.	Description	Qty.
1	1033326	Support Wldt, Steering	1
2	04417	Screw, Hex, M10 X 1.5 X 60, Ss	4
3	01686	Washer, Flat, 0.44b 1.00 .08, Ss	4
4	69234	Clamp, Cable, Stl, 1.00d X 0.62w, 1h	3
5	39349	Washer, Flat, 0.31 Sae	3
6	08709	Nut, Hex, Lock, M8 X 1.25, NI	3
7	1047320	Joint, U, 19mm Id	1
8	1015578	Screw, Set, M8 X 1.25 X 8, Cuppt, Ss, NI	4
9	00912	Key, Sq, 0.19 X 0.19, 1.00l	1
10	223065	Bearing, Flng, 2-Hole, 0.75b [Nyl]	1
11	09740	Screw, Hex, M8 X 1.25 X 20, Ss	2
12	1013164	Shaft, Steering, Wheel	1
13	1012002	Wheel, Steering, 300mm	1
14	1019706	Cap, Steering Wheel	1
15	1014328	Key, Sq, 05mm X 05mm, 25l	1
16	64154	Washer, Flat, 0.53b 1.12d .11, Stl, PI	1
17	08711	Nut, Hex, Lock, M12 X 1.75, NI	1
18	1012437	Bellows, Shaft, Steering	1
19	41142	Washer, Lock, Int-ext, 0.38	1
20	1066409	Relay, 24vdc, 150a, No [Trombetta]	1
21	01684	Washer, Flat, 0.27b 0.69d .05, Ss	2
22	08712	Nut, Hex, Lock, M6 X 1.00, NI, Ss	2

Fig. 9 - Instrument Panel Group

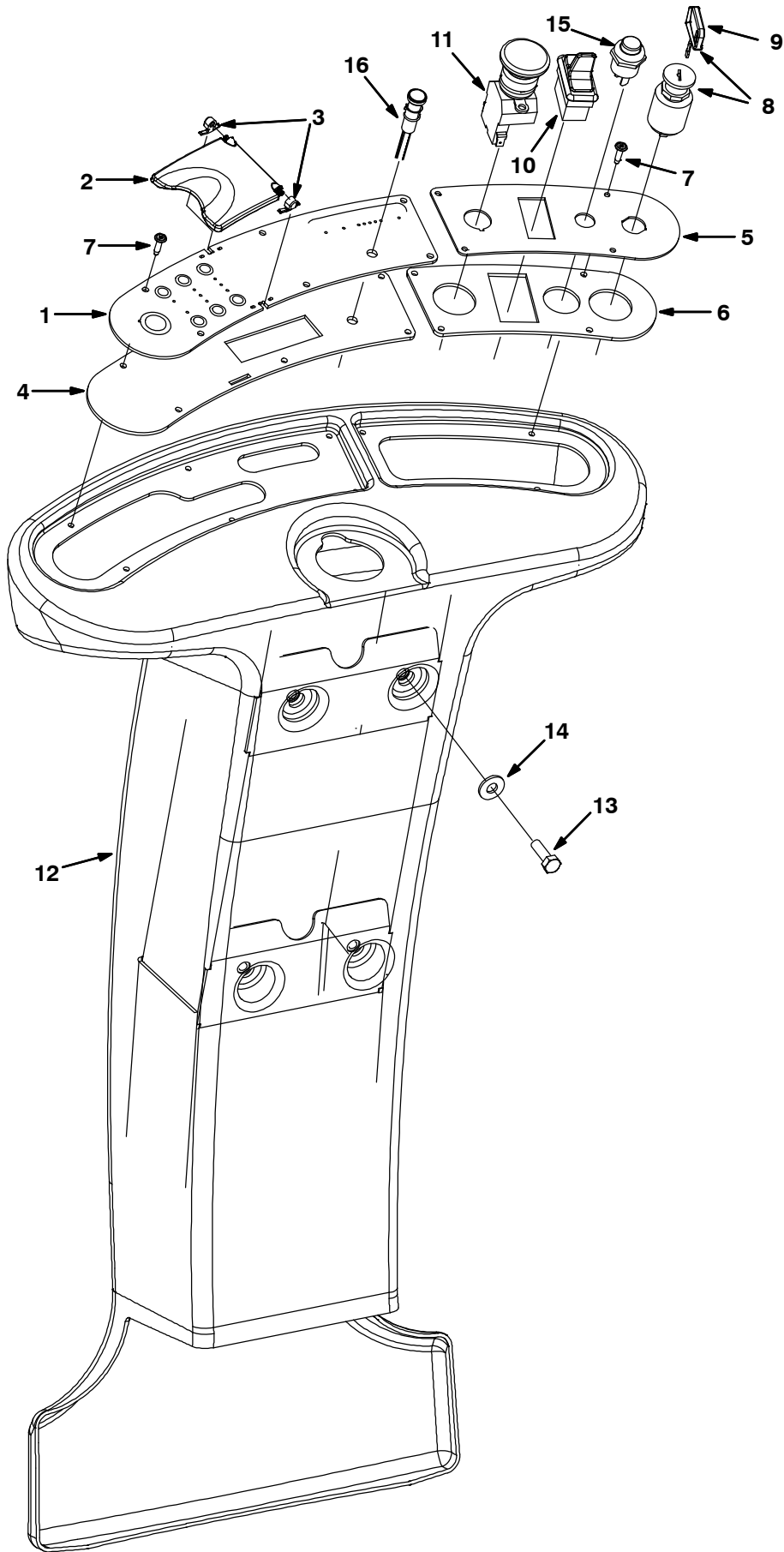

Fig. 9 – Instrument Panel Group

Ref.	Part No.	Description	Qty.	
1	1076470	Panel, Instmt, Lh, Afmkt [T7]	1	
1	1076471	Panel, Instmt, Lh, Afmkt [Ec-h2oT7]	1	
2	1012197	Cover, Panl, Instmt	1	
3	1011952	Block, Pivot, Cover	2	
4	1052607	Gasket, Panl, Instmt, Lh, .13, Foam, Adh	1	
5	1046313	Panel, Instmt, Rh	1	
6	1014080	Gasket, Panl, Instmt, Rh	1	
7	72969	Rivet, Plstc, .181d X 0.720	10	
▽	8	1011402	Switch, Key	1
▲	9	1017696	Key Set, Replmt [F/ Keyswitch 1011402]	1
10	1072040	Switch, Rocker, Spst, Paddle	1	
11	1011735	Switch, Safety, Shutoff	1	
12	1013873	Column, Cntrl, Ce	1	
13	09010	Screw, Hex, M8 X 1.25 X 25, Ss	4	
14	01685	Washer, Flat, 0.31 Ss	4	
15	1014832	Switch, Horn	1	
16	1041822	Light, Led, .312d, 2 Volt [Tri-Color] (ec-H2O Model)	1	

Fig. 10 – Front Drive Wheel Group

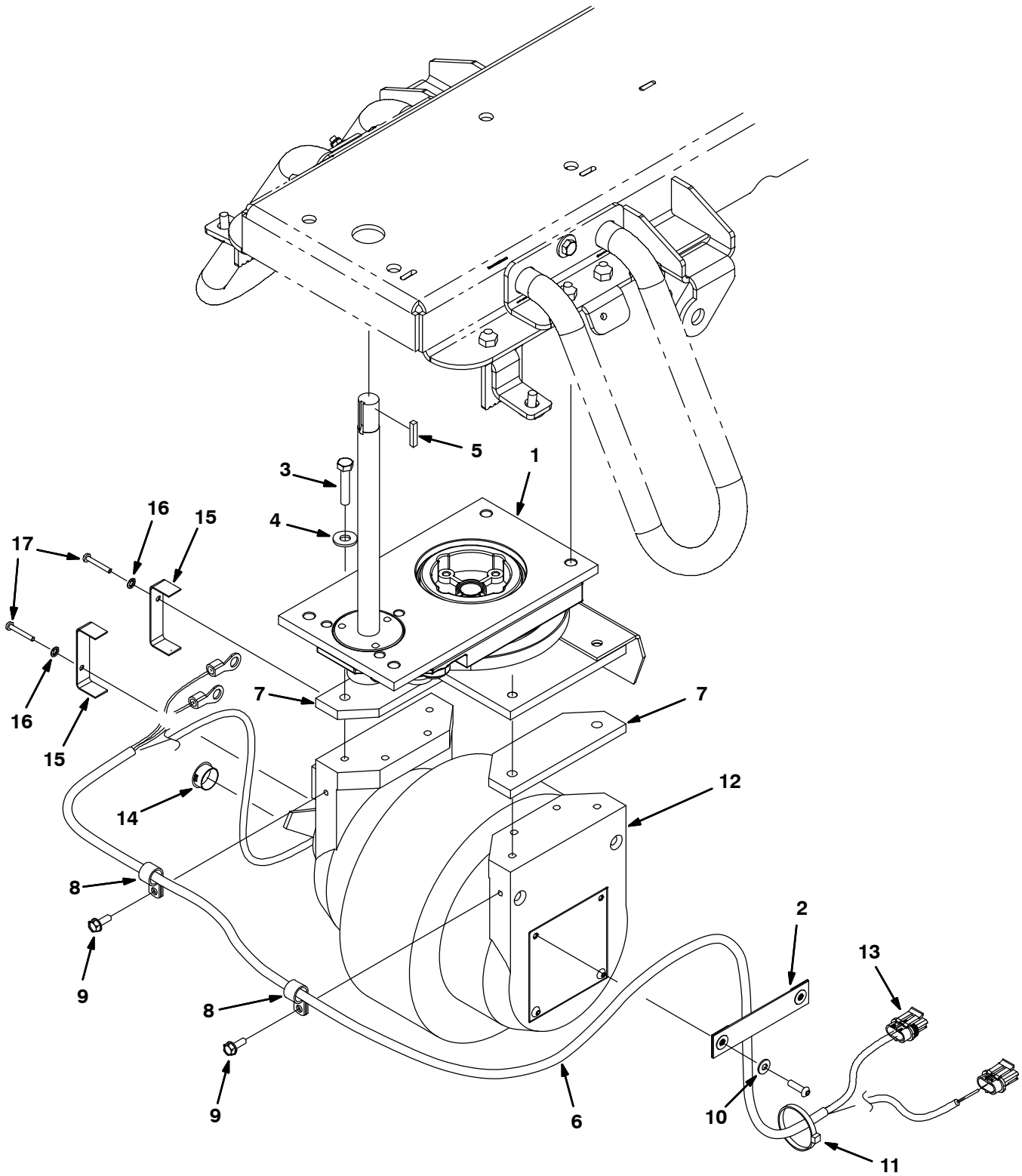

Fig. 10 – Front Drive Wheel Group

Ref.	Part No.	Description	Qty.
1	1019724	Steer-Control Assy, Wheel Drive (See Breakdown)	1
2	1019224	Strap, Nyl	1
3	09010	Screw, Hex, M8 X 1.25 X 25, Ss (Disk Brush)	4
3	09026	Screw, Hex, M8 X 1.25 X 40, Ss (Cylindrical Brush)	4
4	01685	Washer, Flat, 0.31 Ss	4
5	00912	Key, Sq, 0.19 X 0.19, 1.00l	1
6	1073343	Harness, Motor, Brake [T7/Ssr]	1
7	1028873	Plate, Spacer, Drive (Cylindrical Brush)	2
8	140300	Clamp, Cable, Stl, 0.50d [Insulated]	2
9	361339	Screw, Hex, M6 X 1.0 X 16, Fmg	2
10	19066	Washer, Flat, #10	2
11	130773	Tie, Cable, Nyl, 11.0l, .14w, 3.0 Max. D	4
▽	12	9008999 Gearbox Kit, Wheel, 250mm, W/ Connector (Note: Does NOT Include Motor Brake Harness) (See Breakdown)	1
▲	13	1047186 Connector, Fem, 3 Recept [Mp630]	1
	14	130161 Plug, Hole, Rnd, 0.88d, Blk	1
	15	1064972 Bracket, Cord	2
	16	02938 Washer, Lock, Int, 08, Ss	2
	17	33931 Screw, Pan, Phl, M4 X 0.70 X 30, Ss	2

Fig. 11 – Brake Pedal and Accelerator Pedal Group

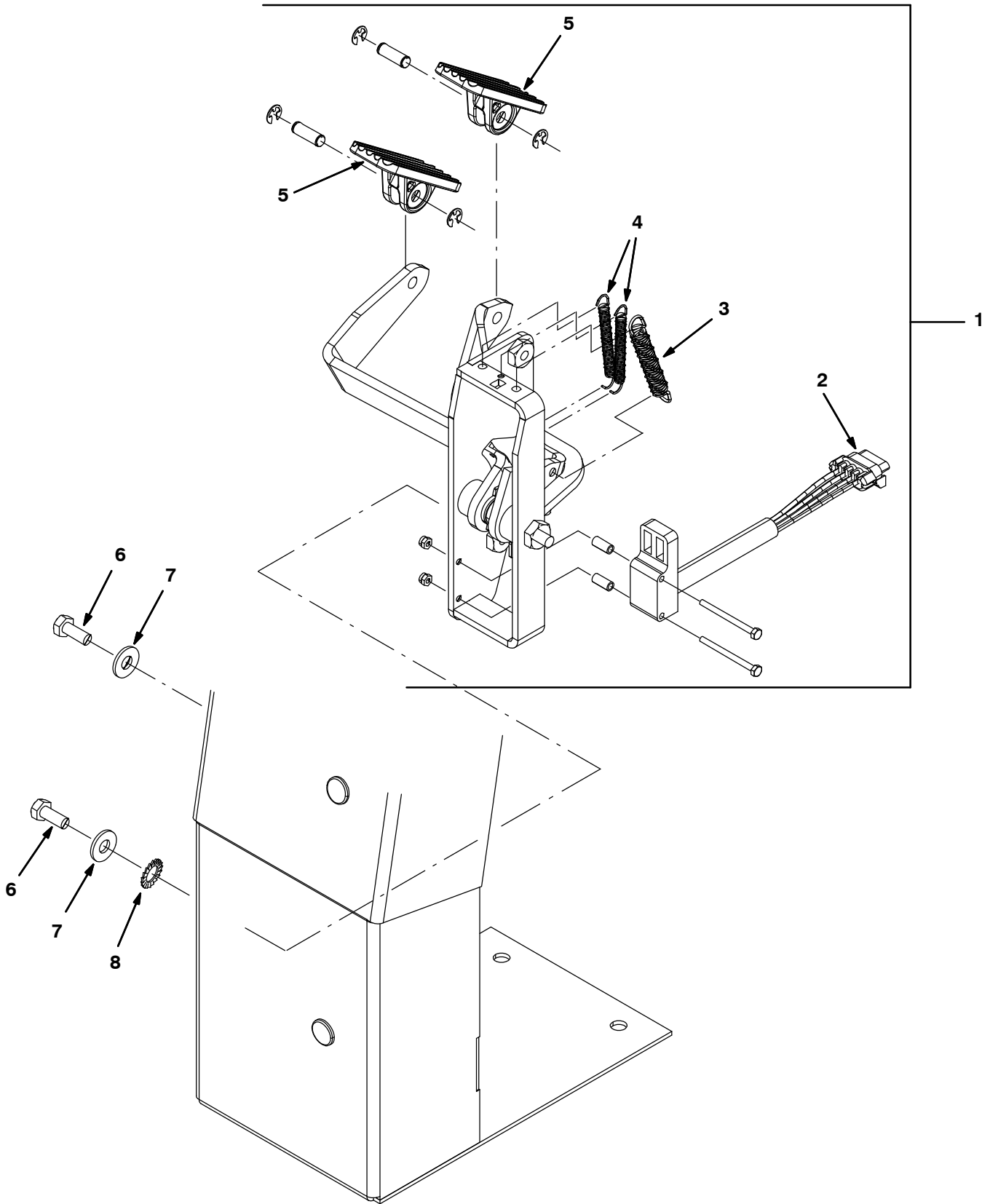

Fig. 11 – Brake Pedal and Accelerator Pedal Group

	Ref.	Part No.	Description	Qty.
▽	1	1072477	Pedal Assy, Accelerator, Brake	1
▲	2	1058687	Vr, Sensor, Position [Hall]	1
▲	3	1031716	Spring, Extn, 0.50od 0.07wir 03.0l	1
▲	4	1061049	Vr, Spring, Extn, 0.35od 0.05wir 02.8l	2
▲	5	1072478	Vr, Pedal, Foot, W/ Tread	2
	6	09740	Screw, Hex, M8 X 1.25 X 20, Ss	2
	7	01685	Washer, Flat, 0.38b 0.88d .08, Ss	2
	8	41141	Washer, Lock, Int-Ext, 0.31	1

Fig. 12 – Disk Scrub Head Lift Group

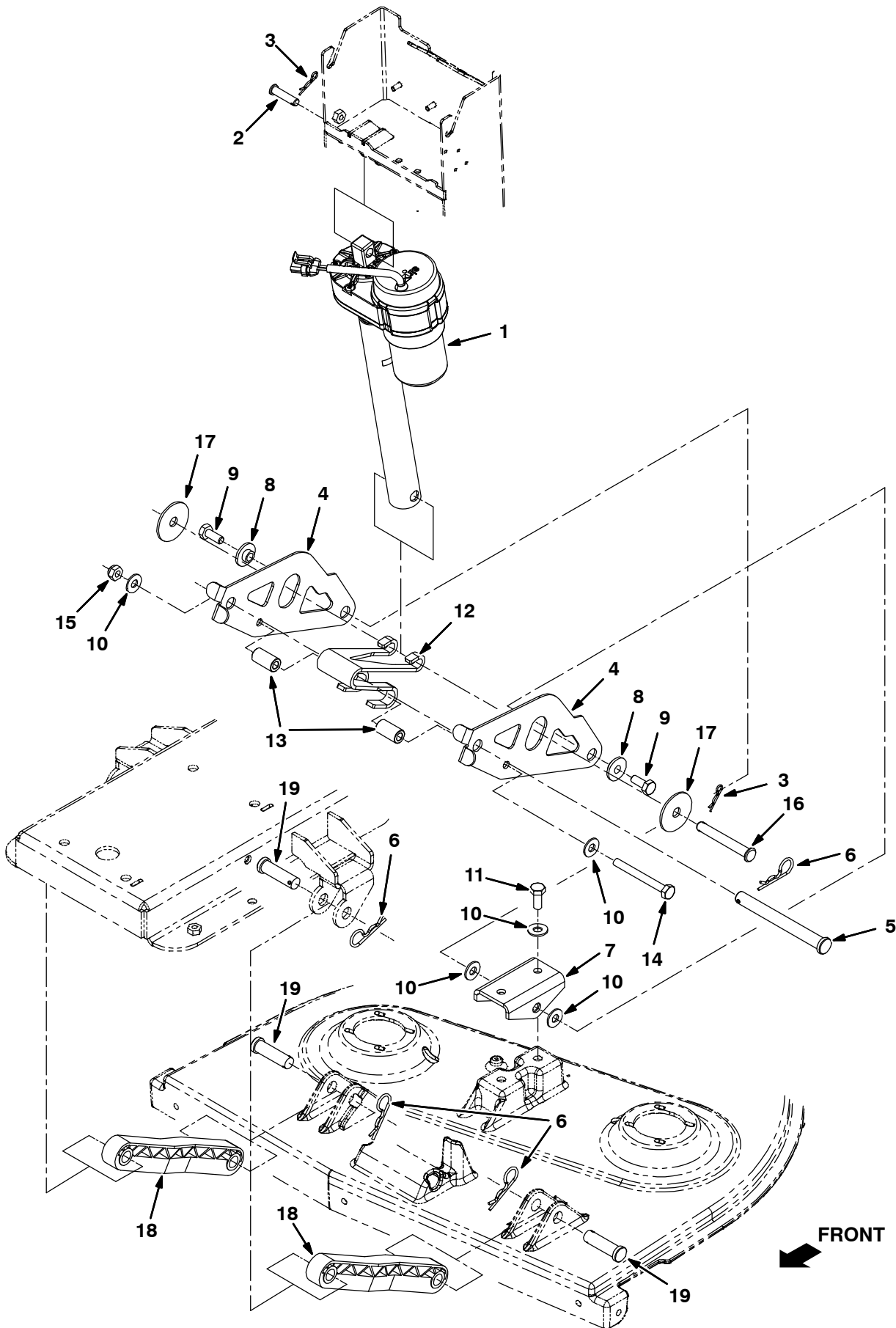

Fig. 12 – Disk Scrub Head Lift Group

Ref.	Part No.	Description	Qty.
1	1056622	Actuator, 24vdc, 04.5strk, 0600lb	1
2	1009356	Pin, Clevis , 10mm X 40l	1
3	86866	Pin, Hair Cotter, 0.38 D .072 Wir	2
4	1013278	Plate, Arm, Cntr, Lift, Scb Head	2
5	1010401	Pin, Clevis, 16d X 150l	1
6	02942	Pin, Hair Cotter, 0.62 D .120 Wir	5
7	1014076	Bracket, Lift	1
8	363087	Bushing, Flng, 0.44b 1.25d 0.25l	2
9	09770	Screw, Hex, M10 X 1.5 X 25, Ss, NI	2
10	01686	Washer, Flat, 0.44b 1.00 .08, Ss	6
11	09028	Screw, Hex, M10 X 1.5 X 25, Ss	2
12	1015413	Spring, Lift, Head, Scb	1
13	1013281	Sleeve, P/M, 18.5d 10.5b 34l 430 Ss	2
14	09746	Screw, Hex, M10 X 1.5 X 90, Ss	1
15	08714	Nut, Hex, Lock, M10 X 1.5, NI, Ss	1
16	1013356	Pin, Clevis, 12mm D X 90mm L	1
17	57048	Washer, Flat, 0.53b 2.13d .11, Stl, PI	2
18	222027	Arm, Lift, Head	2
19	222210	Pin, Clevis, 0.62 D X 2.12l	4

STANDARD PARTS

Fig. 13 – Disk Scrub Head Drive Motor Group, 650 mm

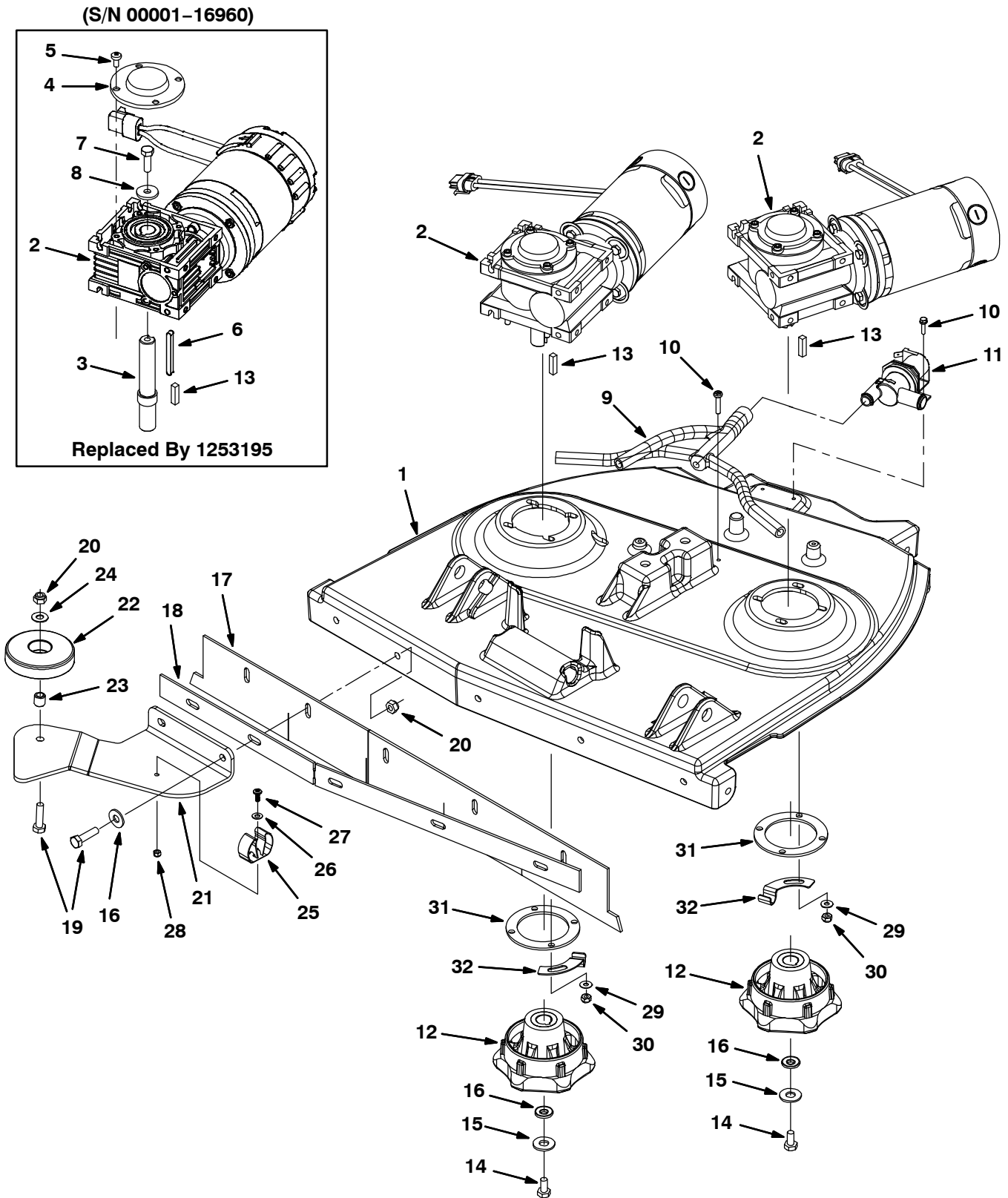

Fig. 13 – Disk Scrub Head Drive Motor Group, 650 mm

Ref.	Part No.	Description	Qty.	
	1	1013560	Head, Scb, 650mm	1
	2	1253195	② Motor, Ele, 24vdc 0285rpm	2
▽	2	1210864	① Motor, Ele, 24vdc 0260rpm (Replaced By 1253195)	2
▲		372878	① Brush Kit, Motor, Ele	1
▲		372879	① Hook, Safety	1
▲		372880	① Cover, Brush, Ele Motor	1
▲	3	1212130	① Shaft, Drive, Brush	1
▲	4	1212132	① Cap, Motor	1
▲	5	363503	① Screw, Pan, Phl, M6 X 1.00 X 12, Ss	4
▲	6	1212131	① Key, Sq, 06mm X 06mm, 60mml	1
▲	7	09740	① Screw, Hex, M8 X 1.25 X 20, Ss	1
▲	8	1017218	① Washer, Flat, 0.32b 1.00d .12, Ss	1
	9	1014776	Manifold, Soltn, 800mm	1
	10	1016520	Screw, Hex, M4 X 0.7 16 Fmg, Ss	3
	11	1214973	Valve, Water, Solenoid, 24vdc, Bm10/Bm10	1
	12	1071636	Hub, Drive, Brush, Disk, 0.75b [6t]	2
	13	00928	Key, Sq, 0.25 X 0.25, 1.00l	2
	14	15675	Screw, Hex, M8 X 1.25 X 16, Ss	2
	15	41186	Washer, Belleville, .31	2
	16	01685	Washer, Flat, 0.31 Ss	7
	17	1013531	Skirt, Rbr, .12, 03.07w 27.27l, 05/ SI	1
	18	1013532	Retainer, Skirt, .08, 1.2w X 24.6l, Blk	1
	19	09011	Screw, Hex, M8 X 1.25 X 30, Ss	6
	20	08713	Nut, Hex, Lock, M8 X 1.25, NI, Ss	6
	21	1052198	Bracket, Wheel, Guiide 650mm	1
	22	1010560	Wheel, Bumper, 80d X 25w, Non-Marking	1
	23	222460	Sleeve, P/, 0.49D 0.318B 0.50L 430Ss	1
	24	140027	Washer, Flat, 0.35b 0.75d .04, Ss	1
	25	1014295	Clip, Grip, Hose, 0.75–1.12, Stl,Blk Vyl (ec-H2O Model)	1
	26	140011	Washer, Flat, 0.21b 0.45d .03, Ss (ec-H2O Model)	1
	27	607006	Screw, Trs, M4 X 0.70 X 12, Phl, PI (ec-H2O Model)	1
	28	33932	Nut, Hex, Lock, M4 X 0.70, NI, Ss (ec-H2O Model)	1
	29	01684	Washer, Flat, 0.27b 0.69d .05, Ss (ec-H2O Model)	2
	30	08712	Nut, Hex, Lock, M6 X 1.0, Ss, NI	8
	31	1013821	Plate, Sppt	2
	32	1052298	Bracket, Support, Hose [T7] (ec-H2O Model)	2

① Serial number (00001–16960)

② Serial number (16961–)

Fig. 14 – Disk Scrub Head Drive Motor Group, 800 mm

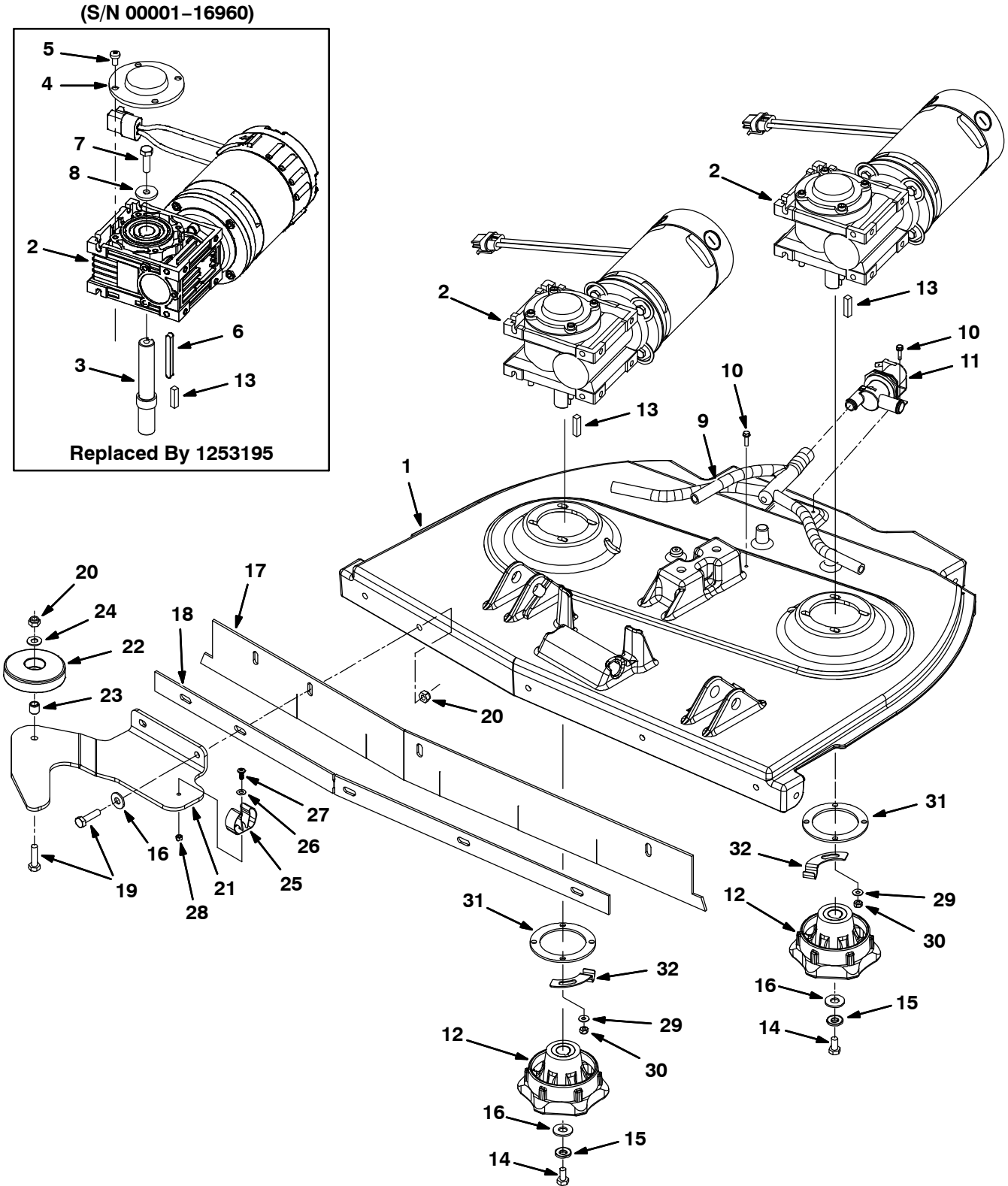

Fig. 14 – Disk Scrub Head Drive Motor Group, 800 mm

Ref.	Part No.	Description	Qty.
1	1012630	Head, Scb, 800mm	1
2	1253195	② Motor, Ele, 24vdc 0285rpm	2
▽	2	① Motor, Ele, 24vdc 0260rpm (Replaced By 1253195)	2
▲	372878	① Brush Kit, Motor, Ele	1
▲	372879	① Hook, Safety	1
▲	372880	① Cover, Brush, Ele Motor	1
▲	3	① Shaft, Drive, Brush	1
▲	4	① Cap, Motor	1
▲	5	① Screw, Pan, Phl, M6 X 1.00 X 12, Ss	4
▲	6	① Key, Sq, 06mm X 06mm, 60mml	1
▲	7	① Screw, Hex, M8 X 1.25 X 20, Ss	1
▲	8	① Washer, Flat, 0.32b 1.00d .12, Ss	1
	9	Manifold, Soltn, 800mm	1
	10	Screw, Hex, M4 X 0.7 16 Fmg, Ss	3
	11	Valve, Water, Solenoid, 24vdc, Bm10/Bm10	1
	12	Hub, Drive, Brush, Disk, 0.75b [6t]	2
	13	Key, Sq, 0.25 X 0.25, 1.00l	2
	14	Screw, Hex, M8 X 1.25 X 16, Ss	2
	15	Washer, Belleville, .31	2
	16	Washer, Flat, 0.31 Ss	7
	17	Skirt, Spray, 800mm	1
	18	Retainer, Skirt, 800mm	1
	19	Screw, Hex, M8 X 1.25 X 30, Ss	6
	20	Nut, Hex, Lock, M8 X 1.25, NI, Ss	6
	21	Bracket, Wheel, Guide	1
	22	Wheel, Bumper, 80d X 25w, Non-Marking	1
	23	Sleeve, P/, 0.49D 0.318B 0.50L 430Ss	1
	24	Washer, Flat, 0.35b 0.75d .04, Ss	1
	25	Clip, Grip, Hose, 0.75–1.12, Stl,Blk Vyl (ec-H2O Model)	1
	26	Washer, Flat, 0.21b 0.45d .03, Ss (ec-H2O Model)	1
	27	Screw, Trs, M4 X 0.70 X 12, Phl, Pl (ec-H2O Model)	1
	28	Nut, Hex, Lock, M4 X 0.70, NI, Ss (ec-H2O Model)	1
	29	Washer, Flat, 0.27b 0.69d .05, Ss (ec-H2O Model)	2
	30	Nut, Hex, Lock, M6 X 1.0, Ss, NI	8
	31	Plate, Sppt	2
	32	Bracket, Support, Hose [T7] (ec-H2O Model)	2

① Serial number (00001–16960)

② Serial number (16961–)

Fig. 15 - Disk Scrub Head Side Squeegee Group, Right

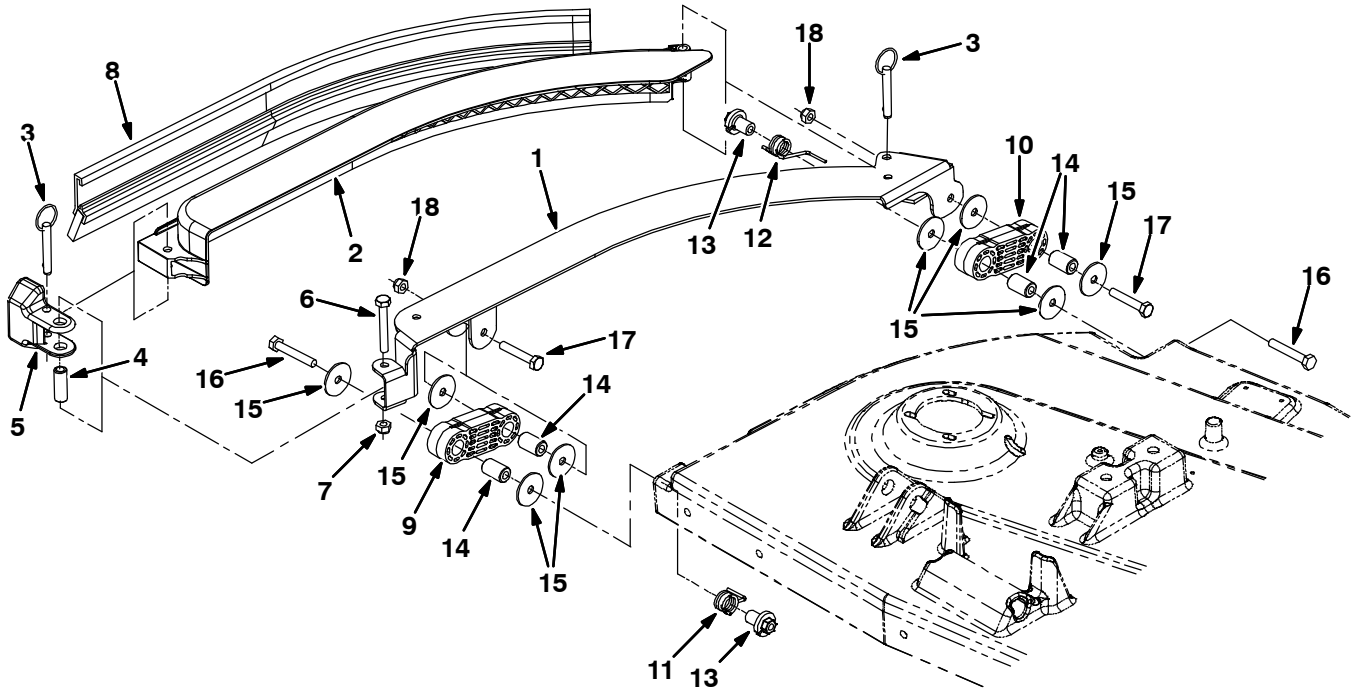

Fig. 15 – Disk Scrub Head Side Squeegee Group, Right

Ref.	Part No.	Description	Qty.
1	1017910	Support Wldt, Sqge, Rh	1
2	1017832	Retainer, Sqge, Rh	1
3	1015989	Pin, Hitch, .312d X 1.62l	2
4	1017495	Sleeve, P/M, 0.496d 0.318b 1.375 Ss	1
5	1074201	Block, Guard, Yellow	1
6	222504	Screw, Hex, M8 X 1.25 X 55, Ss	1
7	08713	Nut, Hex, Lock, M8 X 1.25, NI, Ss	1
8	86859	Squeegee Assy, Side [Linatex] (Standard)	1
8	1058731	Squeegee Assy, Side, Disc, Ure (Optional)	1
8	1058729	Squeegee Assy, Side, Disc, Gum (Optional)	1
9	1010876	Link, Sqge	1
10	1017785	Link, Sqge	1
11	1011344	Spring, Tors	1
12	1011334	Spring, Tors	1
13	1011317	Retainer, Spring	2
14	1011717	Sleeve, P/M, 0.625d 0.318b 1.00 L 430ss	4
15	1011719	Washer, Flat, 0.33b 1.38d .075, Ss	8
16	49694	Screw, Hex, M8 X 1.25 X 50, Ss	2
17	222505	Screw, Hex, M8 X 1.25 X 45, Ss	2
18	08713	Nut, Hex, Lock, M8 X 1.25, NI, Ss	2

Fig. 16 - Disk Scrub Head Side Squeegee Group, Left

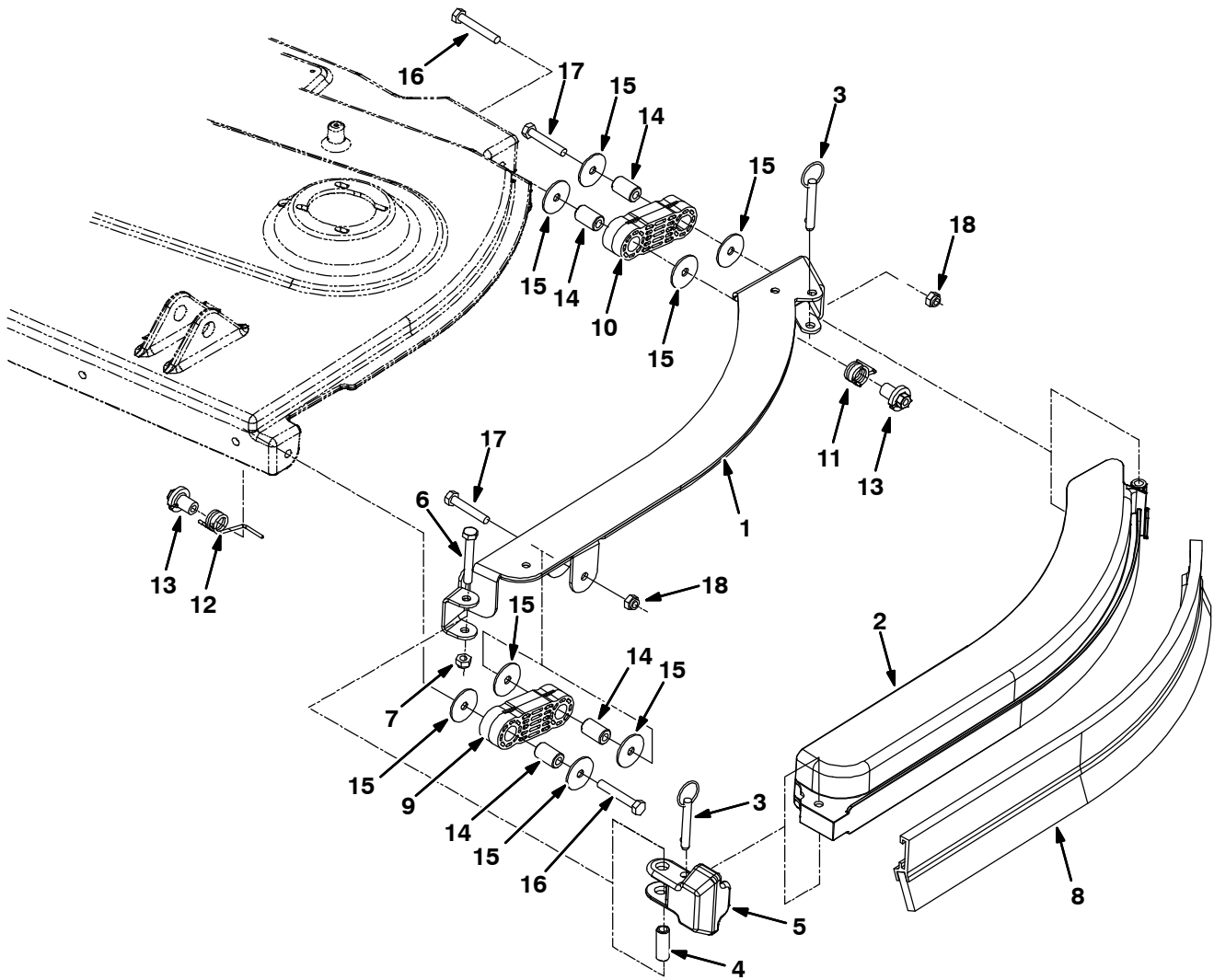

Fig. 16 – Disk Scrub Head Side Squeegee Group, Left

Ref.	Part No.	Description	Qty.
1	1017534	Support Wldt, Sqge, Lh	1
2	1017653	Retainer, Sqge, Lh	1
3	1015989	Pin, Hitch, .312d X 1.62l	2
4	1017495	Sleeve, P/M, 0.496d 0.318b 1.375 Ss	1
5	1074201	Block, Guard, Yellow	1
6	222504	Screw, Hex, M8 X 1.25 X 55, Ss	1
7	08713	Nut, Hex, Lock, M8 X 1.25, NI, Ss	1
8	86859	Squeegee Assy, Side [Linatex] (Standard)	1
8	1058731	Squeegee Assy, Side, Disc, Ure (Optional)	1
8	1058729	Squeegee Assy, Side, Disc, Gum (Optional)	1
9	1010876	Link, Sqge	1
10	1017785	Link, Sqge	1
11	1011344	Spring, Tors	1
12	1011334	Spring, Tors	1
13	1011317	Retainer, Spring	2
14	1011717	Sleeve, P/M, 0.625d 0.318b 1.00 L 430ss	4
15	1011719	Washer, Flat, 0.33b 1.38d .075, Ss	8
16	49694	Screw, Hex, M8 X 1.25 X 50, Ss	2
17	222505	Screw, Hex, M8 X 1.25 X 45, Ss	2
18	08713	Nut, Hex, Lock, M8 X 1.25, NI, Ss	2

Fig. 17 - Cylindrical Scrub Head Lift Group

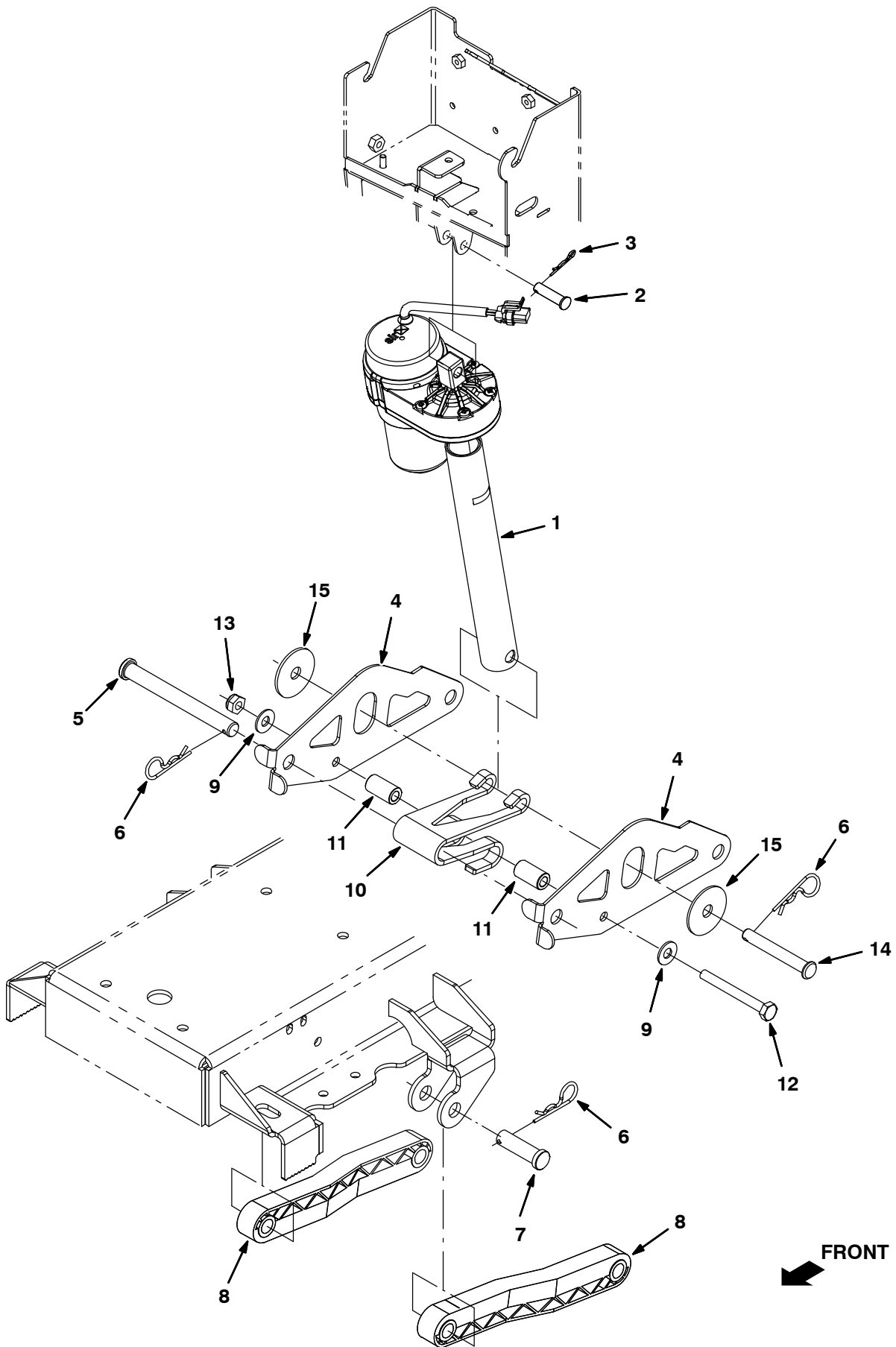

Fig. 17 – Cylindrical Scrub Head Lift Group

Ref.	Part No.	Description	Qty.
1	1056622	Actuator, 24vdc, 04.5strk, 0600lb	1
2	1009356	Pin, Clevis , 10mm X 40l	1
3	86866	Pin, Hair Cotter, 0.38 D .072 Wir	1
4	1013278	Plate, Arm, Cntr, Lift, Scb Head	2
5	1010401	Pin, Clevis, 16d X 150l	1
6	02942	Pin, Hair Cotter, 0.62 D .120 Wir	4
7	222210	Pin, Clevis, 0.62 D X 2.12l	2
8	222027	Arm, Lift, Head	2
9	01686	Washer, Flat, 0.44b 1.00 .08, Ss	2
10	1015413	Spring, Lift, Head, Scb	1
11	1013281	Sleeve, P/M, 18.5d 10.5b 34l 430 Ss	2
12	09746	Screw, Hex, M10 X 1.5 X 90, Ss	1
13	08714	Nut, Hex, Lock, M10 X 1.5, NI, Ss	1
14	1013356	Pin, Clevis, 12mm D X 90mm L	1
15	57048	Washer, Flat, 0.53b 2.13d .11, Stl, Pl	2

Fig. 18 – Cylindrical Scrub Head Group, 700 mm

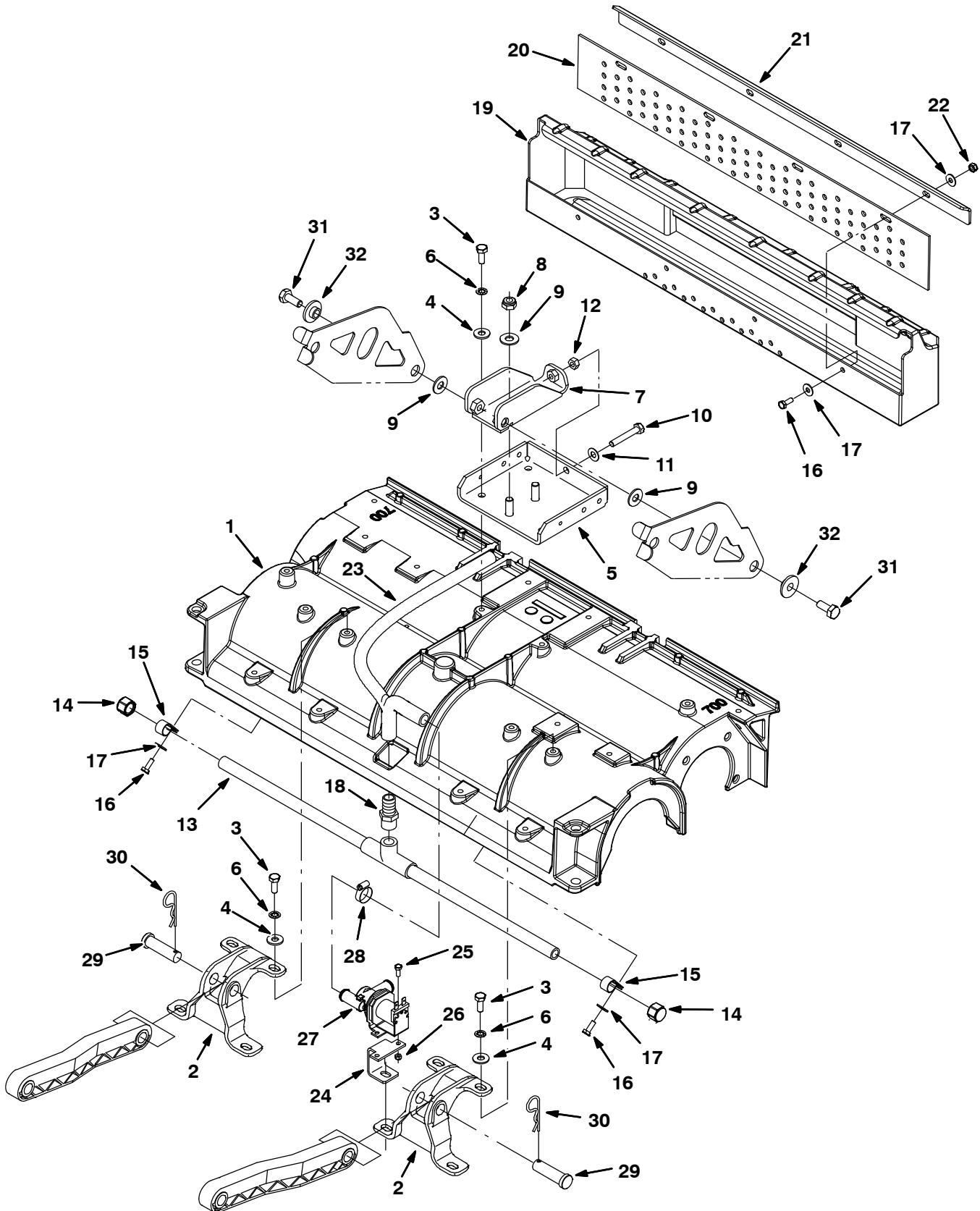

Fig. 18 – Cylindrical Scrub Head Group, 700 mm

Ref.	Part No.	Description	Qty.
1	1029131	Housing, Machining, Head, 70 Cm Cyl	1
2	1031416	Mount, Link, Mach	2
3	12273	Screw, Hex, M8 X 1.25 X 20, Ss, NI	12
4	01685	Washer, Flat, 0.31, Ss	12
5	1029531	Channel, Lift	1
6	43952	Washer, Lock, Int, 0.31, Ss	12
7	1029538	Bracket, Lift, Upper	1
8	08714	Nut, Hex, Lock, M10 X 1.5, NI, Ss	2
9	01686	Washer, Flat, 0.44b 1.00d .08, Ss	4
10	578717	Screw, Hex, M8 X 1.25 X 50, Ss, FI	1
11	140027	Washer, Flat, 0.35b 0.75d .04, Ss	1
12	07786	Nut, Hex, Std, M8 X 1.25, Ss	1
13	1029215	Tube Assy, Bar, Spray [70cm]	1
14	1025580	Fitting, Pipe, Cap, P06, Nyl	2
15	33584	Clamp, Cable, Stl, 0.63d X 0.50w, 1h	2
16	11329	Screw, Hex, M6 X 1.0 X 16, Ss, NI	7
17	01684	Washer, Flat, 0.25, Ss	12
18	41440	Fitting, Plstc, Str, Bm10/Pm08	1
19	9005805	Hopper, Debris, 70cm, Black, Afmkt	1
20	1029274	Skirt, Tray, Debris [70cm]	1
21	1029272	Bracket, Lip, Debris, 70cm	1
22	07785	Nut, Hex, Std, M6 X 1.00, A2, Ss	5
23	1031132	Hose, Molded	1
24	1031037	Bracket, Mtg, Valve	1
25	09738	Screw, Hex, M5 X 0.8 X 12, Ss	2
26	09739	Nut, Hex, Lock, M5 X 0.80, NI, Ss	2
27	1013599	Valve, Water, Solenoid, 24vdc, 10bm/10bm	1
28	54333	Clamp, Hose, Wormdrive, 0.31-0.88d, .31w	3
29	222210	Pin, Clevis, 0.62d X 2.12l	2
30	02942	Pin, Cotter, Hair, 0.62d .120 Wir	2
31	09028	Screw, Hex, M10 X 1.5 X 25, Ss	2
32	363087	Bushing, Flng, 0.44b 1.25d 0.25l	2

Fig. 19 – Cylindrical Scrub Head Group, 800 mm

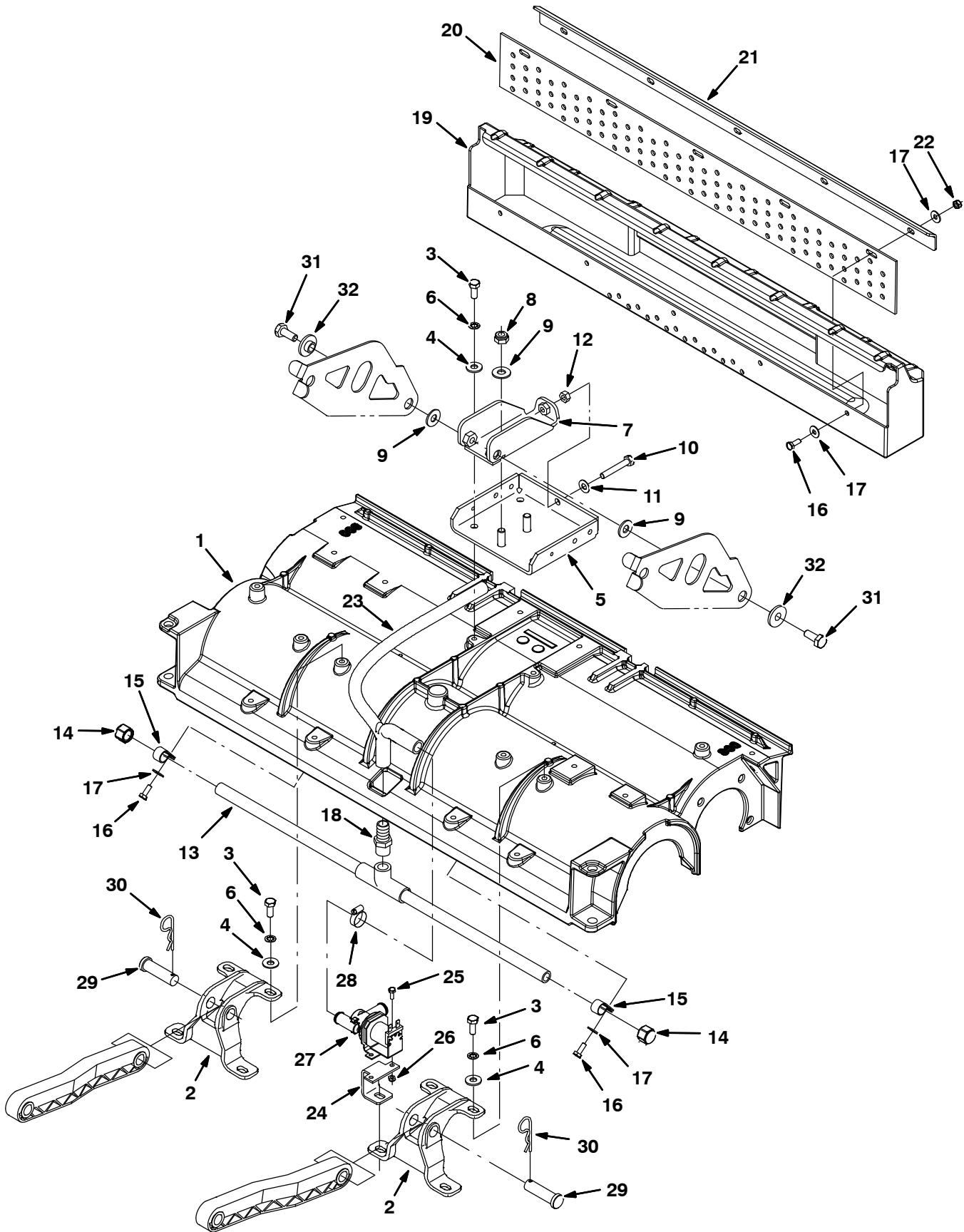

Fig. 19 – Cylindrical Scrub Head Group, 800 mm

Ref.	Part No.	Description	Qty.
1	1030273	80cm Scrubhead, Machining, T7/Cyl	1
2	1031416	Mount, Link, Mach	2
3	12273	Screw, Hex, M8 X 1.25 X 20, Ss, NI	12
4	01685	Washer, Flat, 0.31, Ss	12
5	1029531	Channel, Lift	1
6	43952	Washer, Lock, Int, 0.31, Ss	12
7	1029538	Bracket, Lift, Upper	1
8	08714	Nut, Hex, Lock, M10 X 1.5, NI, Ss	2
9	01686	Washer, Flat, 0.44b 1.00d .08, Ss	4
10	578717	Screw, Hex, M8 X 1.25 X 50, Ss, FI	1
11	140027	Washer, Flat, 0.35b 0.75d .04, Ss	1
12	07786	Nut, Hex, Std, M8 X 1.25, Ss	1
13	1031029	Tube Assy, Bar, Spray [80cm]	1
14	1025580	Fitting, Pipe, Cap, P06, Nyl	2
15	33584	Clamp, Cable, Stl, 0.63d X 0.50w, 1h	2
16	11329	Screw, Hex, M6 X 1.0 X 16, Ss, NI	7
17	01684	Washer, Flat, 0.25, Ss	12
18	41440	Fitting, Plstc, Str, Bm10/Pm08	1
19	9005806	Hopper, Debris, 80cm, Black, Afmkt	1
20	1025273	Skirt, Tray, Debris [80cm]	1
21	1025150	Lip, Tray, Debris, Scb Head, 80cm	1
22	07785	Nut, Hex, Std, M6 X 1.00, A2, Ss	5
23	1031132	Hose, Molded	1
24	1031037	Bracket, Mtg, Valve	1
25	09738	Screw, Hex, M5 X 0.8 X 12, Ss	2
26	09739	Nut, Hex, Lock, M5 X 0.80, NI, Ss	2
27	1013599	Valve, Water, Solenoid, 24vdc, 10bm/10bm	1
28	54333	Clamp, Hose, Wormdrive, 0.31-0.88d, .31w	3
29	222210	Pin, Clevis, 0.62d X 2.12l	2
30	02942	Pin, Cotter, Hair, 0.62d .120 Wir	2
31	09028	Screw, Hex, M10 X 1.5 X 25, Ss	2
32	363087	Bushing, Flng, 0.44b 1.25d 0.25l	2

Fig. 20 – Cylindrical Scrub Head Drive Group, Right Side

	Ref.	Part No.	Description	Qty.
▽	1	604980	Motor, Ele, 24vdc 0.75hp 1500rpm 23.0a	1
▲	2	00954	Key, Sq, 0.12 X 0.12, 1.00l	1
	3	01684	Washer, Flat, 0.25, Ss	5
	4	1032496	Harness, Adapter, Motor, Cylrc1	1
	5	608964	Boot, 90deg .27id 0.64id 1.79l, Blk	2
	6	1034845	Strip, Pye, Hi-dns, 0.25 01.75w 05.6l	1
	7	140027	Washer, Flat, 0.35b 0.75d .04, Ss	2
	8	43952	Washer, Lock, Int, 0.31, Ss	8
	9	1044386	Bracket, Mtg, Motor	1
	10	12273	Screw, Hex, M8 X 1.25 X 20, Ss, NI	8
	11	01685	Washer, Flat, 0.31, Ss	10
	12	1025026	Screw, Hex, M8 X 1.25 X 180, Ss	1
	13	08713	Nut, Hex, Lock, M8 X 1.25, NI, Ss	1
	14	578717	Screw, Hex, M8 X 1.25 X 50, Ss	1
	15	07786	Nut, Hex, Std, M8 X 1.25, Ss	1
	16	1033528	Sheave, 06grv, 1.33pd 0.50b, Alm [Pj]	1
	17	222818	Screw, Set, #08-32 X 0.25, NI	2
	18	1035888	Belt, Drive, 6grv, 508 L X 14 W, [6pj]	1
	19	1021036	Bracket, Motor [Machined]	1
	20	41360	Bearing, Ball, 0.59b 1.26d 0.35w[2seal]	2
	21	1002077	Tube, 0.81d 0.59b 00.5l	1
	22	1021050	Shaft, Drive	1
	23	378805	Plug, Drive, Brush, Mach	1
	24	00911	Key, Sq, 0.19 X 0.19, 0.75l	1
	25	79246	Screw, Flt, M8 X 1.25 X 20, Ss 18-8	2
	26	1035173	Sheave, 06grv, 2.96pd 0.59b, Alm [Pj]	1
	27	00961	Key, Sq, 0.19 X 0.19, 0.50l	1
	28	1022401	Gasket, Cover, Belt	1
	29	1022807	Cover, Belt	1
▽		1057922	Door Assy, Cyl Head [7100]	1
▲	30	390996	Screw, Flt, M10 X 1.5 X 20, 10.9, NI	1
▲	31	1044145	Door, Brush	1
▲▽		222752	Plug Assy, Idler, Brush	1
▲▲	32	222184	Pin, Roll, .094 D X 0.25l, .094/.097	1
▲▲	33	222177	Shaft, Idler Plug	1
▲▲	34	1057629	Plug, Idler, Brush [Sgl Brg]	1
▲▲	35	01516	Ring, Retaining, Ext, 0.59d, Basic	1
	36	1029358	Deflector, Water, Cyl Head	2
	37	11329	Screw, Hex, M6 X 1.0 X 16, Ss, NI	5

Fig. 21 – Cylindrical Scrub Head Drive Group, Left Side

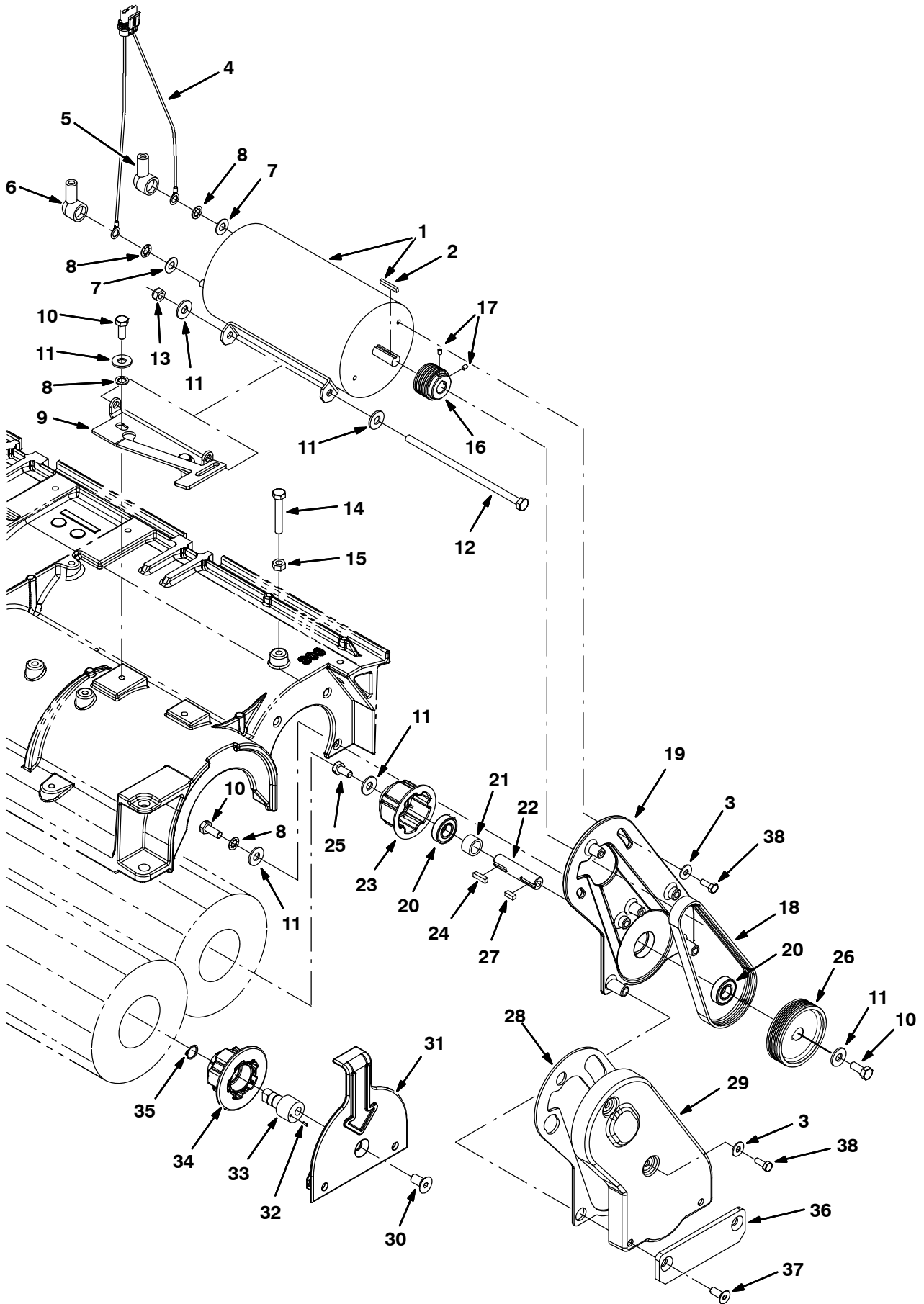

Fig. 21 – Cylindrical Scrub Head Drive Group, Left Side

	Ref.	Part No.	Description	Qty.
▽	1	604980	Motor, Ele, 24vdc 0.75hp 1500rpm 23.0a	1
▲	2	00954	Key, Sq, 0.12 X 0.12, 1.00l	1
	3	01684	Washer, Flat, 0.25, Ss	6
	4	1032496	Harness, Adapter, Motor, Cylrcl	1
	5	608964	Boot, 90deg .27id 0.64id 1.79l, Blk	1
	6	608963	Boot, 90deg .27id 0.64id 1.79l, Red	1
	7	140027	Washer, Flat, 0.35b 0.75d .04, Ss	2
	8	43952	Washer, Lock, Int, 0.31, Ss	8
	9	1044386	Bracket, Mtg, Motor	1
	10	12273	Screw, Hex, M8 X 1.25 X 20, Ss, NI	7
	11	01685	Washer, Flat, 0.31, Ss	10
	12	1025026	Screw, Hex, M8 X 1.25 X 180, Ss	1
	13	08713	Nut, Hex, Lock, M8 X 1.25, NI, Ss	1
	14	578717	Screw, Hex, M8 X 1.25 X 50, Ss	1
	15	07786	Nut, Hex, Std, M8 X 1.25, Ss	1
	16	1033528	Sheave, 06grv, 1.33pd 0.50b, Alm [Pj]	1
	17	222818	Screw, Set, #08–32 X 0.25, NI	2
	18	1035888	Belt, Drive, 6grv, 508 L X 14 W, [6pj]	1
	19	1021036	Bracket, Motor [Machined]	1
	20	41360	Bearing, Ball, 0.59b 1.26d 0.35w[2seal]	2
	21	1002077	Tube, 0.81d 0.59b 00.5l	1
	22	1021050	Shaft, Drive	1
	23	378805	Plug, Drive, Brush, Mach	1
	24	00911	Key, Sq, 0.19 X 0.19, 0.75l	1
	25	49826	Screw, Hex, M8 X 1.25 X 16, Ss, NI	1
	26	1035173	Sheave, 06grv, 2.96pd 0.59b, Alm [Pj]	1
	27	00961	Key, Sq, 0.19 X 0.19, 0.50l	1
	28	1022401	Gasket, Cover, Belt	1
	29	1022807	Cover, Belt	1
▽		1057922	Door Assy, Cyl Head [7100]	1
▲	30	390996	Screw, Flt, M10 X 1.5 X 20, 10.9, NI	1
▲	31	1044145	Door, Brush	1
▲▽		222752	Plug Assy, Idler, Brush	1
▲▲	32	222184	Pin, Roll, .094 D X 0.25l, .094/.097	1
▲▲	33	222177	Shaft, Idler Plug	1
▲▲	34	1057629	Plug, Idler, Brush [Sgl Brg]	1
▲▲	35	01516	Ring, Retaining, Ext, 0.59d, Basic	1
	36	1034845	Strip, Pye, Hi-dns, 0.25 01.75w 05.6l	1
	37	79246	Screw, Flt, M8 X 1.25 X 20, Ss 18–8	2
	38	11329	Screw, Hex, M6 X 1.0 X 16, Ss, NI	7

Fig. 22 - Cylindrical Scrub Head Squeegee Group

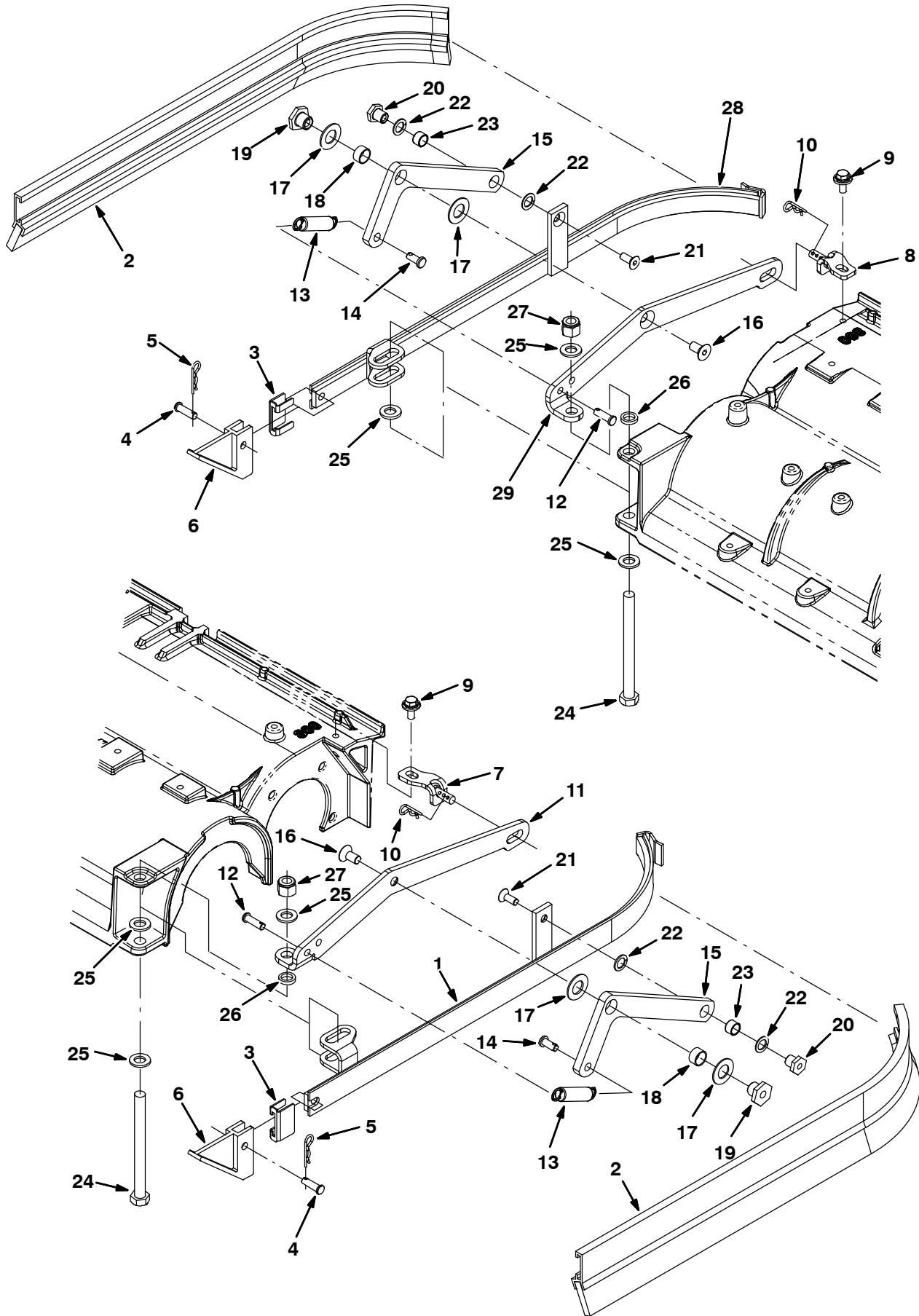

Fig. 22 – Cylindrical Scrub Head Squeegee Group

Ref.	Part No.	Description	Qty.
1	391328	Frame Wldt, Sqge, Side, Lh	1
2	391334	Squeegee Assy, Side [Linatex] (Standard)	2
2	1058728	Squeegee Assy, Cylrcl, Ure [T7/Ssr] (Optional)	2
2	1058715	Squeegee Assy, Cylrcl, Gum [T7/Ssr] (Optional)	2
3	86759	Retainer, Sqge	2
4	69582	Pin, Clevis, 0.31d X 1.00l	2
5	44906	Pin, Cotter, Hair, 0.69d .092 Wir	2
6	1074203	Guide, Sqge, Side, Yellow	2
7	1029380	Angle Wldt, Stop, Lh	1
8	1029368	Angle Wldt, Stop, Rh	1
9	1020341	Screw, Hex, M8 X 1.25 X 20, Ss, Sems	2
10	44906	Pin, Cotter, Hair, 0.69d .092 Wir	2
11	1030365	Arm, Mtg, Link, Lh Sqge, Cylrcl Head	1
12	69582	Pin, Clevis, 0.31d X 1.00l	2
13	15047	Spring, Extn, 0.62od X 0.08wir, 3.0l	2
14	39019	Pin, Clevis, 0.37d X 0.75l	2
15	25709	Bellcrank, Lift, Sqge	2
16	380587	Screw, Flt, M10 X 1.5 X 20, Ss, 18-8	2
17	64425	Washer, Thrust, 0.61b 1.25d .06, Fgl	4
18	71607	Bushing, Sleeve, 0.63b 0.72d 0.38l	2
19	391345	Nut, T, M10 X 1.50 X 0.62od X 0.5l	2
20	391346	Nut, T, M8 X 1.25 X 0.50od X 0.5l	2
21	79246	Screw, Flt, M8 X 1.25 X 20, Ss 18-8	2
22	86860	Bearing, Thrust, 0.50b 0.87d 0.06w	4
23	64173	Bushing, Sleeve, 0.50b 0.59d 0.38l, Stl	2
24	45280	Screw, Hex, .50-13 X 5.50, G5	2
25	33925	Washer, Flat, M12, Ss	6
26	1031077	Bushing, Sleeve, 0.51b 0.75d 0.16l	2
27	02931	Nut, Hex, Lock, .50-13, NI, Ss	2
28	391327	Frame Wldt, Sqge, Side, Rh	1
29	1030026	Arm, Mtg, Link, Rh Sqge, Cylrcl Head	1

Fig. 23 - Recovery Tank Group

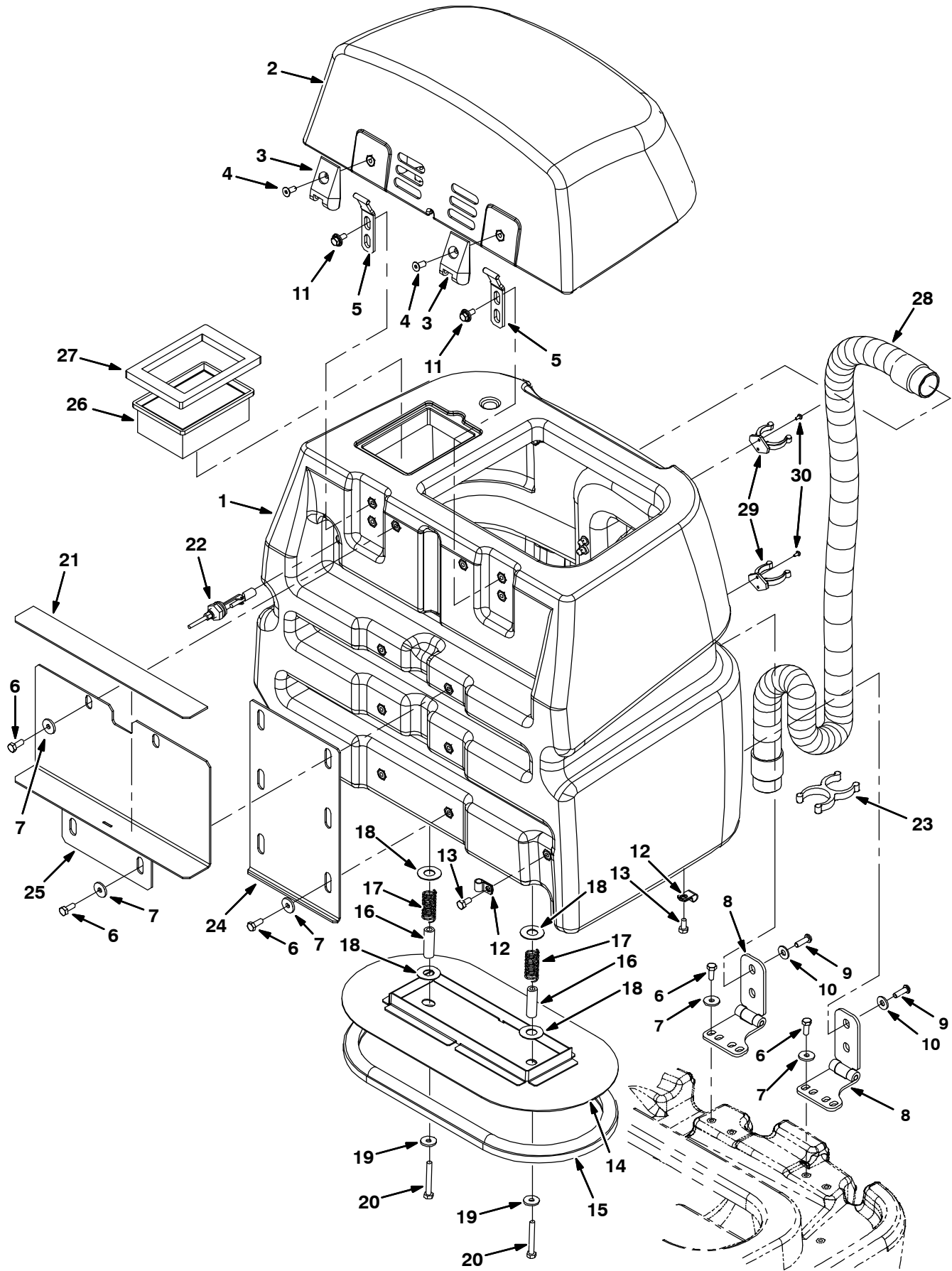

Fig. 23 – Recovery Tank Group

Ref.	Part No.	Description	Qty.
1	1012698	Tank, Recvy, Rm-Tl, Trimmed [T7]	1
2	1013874	Cover, Tank, Recvy, Ce	1
3	1050554	Hinge, Leaf	2
4	222463	Screw, Flt, M8 X 1.25 X 20, Blk	2
5	1012055	Hinge Wldt, Cover	2
6	09740	Screw, Hex, M8 X 1.25 X 20, Ss	12
7	1017218	Washer, Flat, 0.321b 1.00d .12, Ss	12
8	1018304	Hinge, 10mm Pin, Crs, Blk [T7]	2
9	393135	Screw, Btn, M8 X 1.25 X 20, Blk	4
10	1016435	Washer, Flat, 0.52b 0.75d .06, Stl, Blk	4
11	1020341	Screw, Hex, M8 X 1.25 X 20, Ss, Sems	4
12	82829	Clamp, Cable, Stl, 0.63d X 0.75w, 1hole	2
13	15675	Screw, Hex, M8 X 1.25 X 16, Ss	2
14	1016855	Plate Wldt, Seal, Tank	1
15	1020301	Seal, Afrmkt, Bulb, Clsd Cell, Adh, 8ft	1
16	1016871	Spacer, Seal, Tank	2
17	397255	Spring, Cmpr, 0.85od .08wir 2.0l	2
18	605385	Washer, Flat, 0.69b 1.50d .05, Ss	4
19	1017218	Washer, Flat, 0.321b 1.00d .12, Ss	2
20	77270	Screw, Hex, M8 X 1.25 X 60, Ss	2
21	1017705	Pad, Rbr	1
22	385685	Sensor, Level, Liquid, 14vdc	1
23	1014079	Clip, Grip, Hose, 1.50id, Dbl, Blk Pyp	1
24	1017000	Angle, Sppt, Tank	1
25	1017668	Bracket Wldt, Tank, Sppt	1
26	1037821	Filter, Panl, Dust, 2.3 X 4.5 X 6.4	1
27	1016392	Gasket, Fltr, Tank	1
28	1207882	Hose, Vacuum, 1.50id X 057.1l, 2cuff, Pu	1
29	1001992	Clip, Hose, Gripper, 1.75id, Blk Ny	2
30	391403	Screw, Pan, M4 X 0.7 X 8, Ss	4

Fig. 24 – Vacuum Fan Group

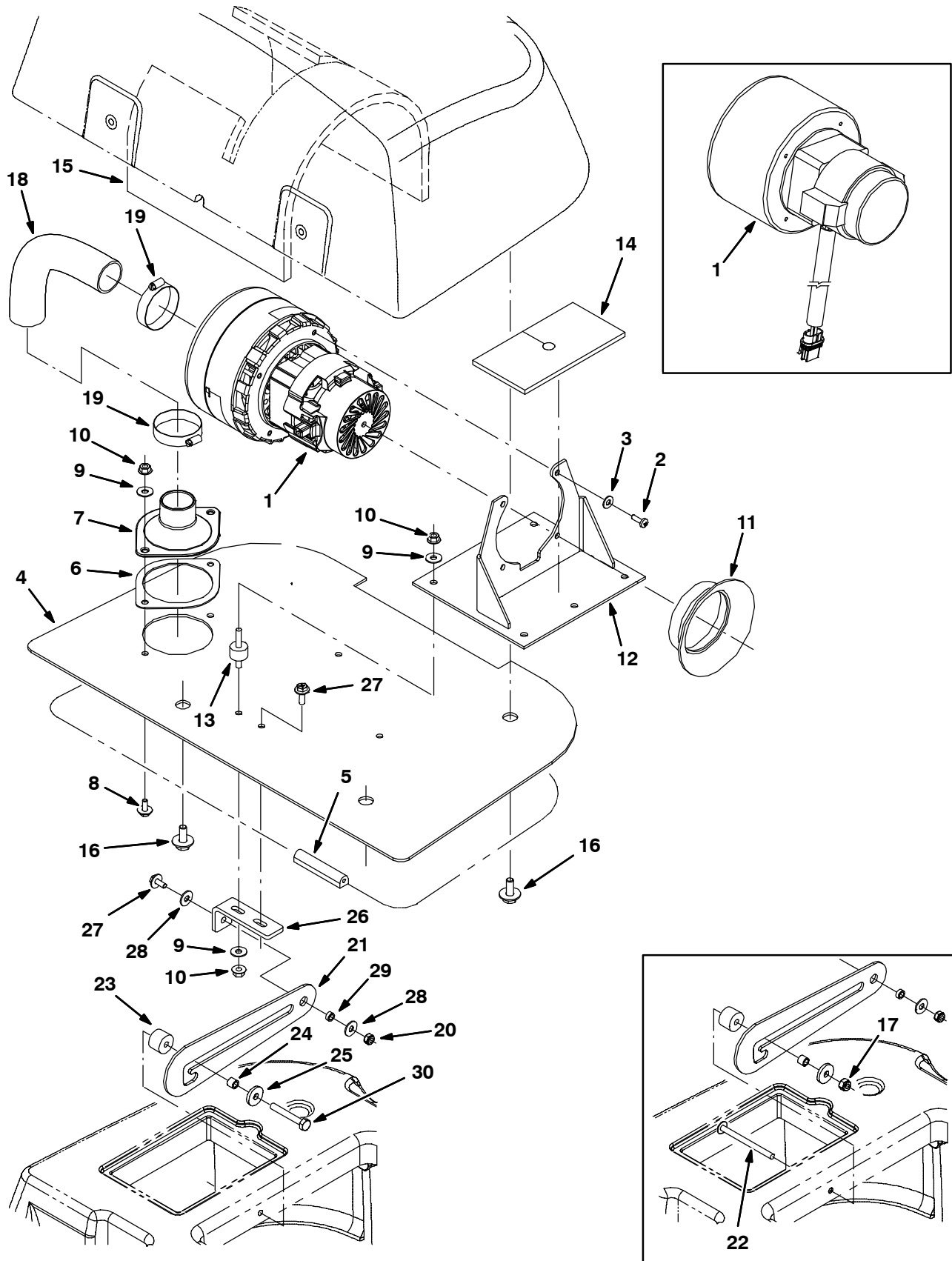

Fig. 24 – Vacuum Fan Group

Ref.	Part No.	Description	Qty.	
1	1256475	④ Fan, Vacuum, 5.7d, 024vdc, 3 Stage [Bpp] (See Breakdown)	1	
1	1021064	③ Fan, Vacuum, 5.7d, 024vdc, 3 Stage [Bpp] (See Breakdown) (Replaced By 1256475)	1	
2	1015506	Screw, Pan, M5 X 16, F/ Plstc	4	
3	19066	Washer, Flat, #10	4	
4	1011127	Plate, Mtg, Fan	1	
5	1013611	Seal, Cover, Recvy	1	
6	1014858	Gasket, Adapter	1	
7	1014711	Adaptor, Hose	1	
8	1034731	Screw, Hex, M6 X 1.00 X 16, Ss, Sems	2	
9	01684	Washer, Flat, 0.25 Ss	9	
10	07790	Nut, Hex, Flng, M6 X 1.00	9	
11	1011140	Seal, Fan	1	
12	1011103	Bracket Wldt, Mtg, Fan	1	
13	1011093	Isolator, Vib, .75d, M6 Stud Both Ends	3	
▽	9003365	Insulation Kit, Acstc, Vacfan	1	
▲	14	1028514	Insulation, Acstc, Vacfan	1
▲	15	1028515	Insulation, Acstc, Hsng, Vacfan	1
16	1020341	Screw, Hex, M8 X 1.25 X 20, Ss, Sems	4	
17	41169	① Nut, Hex, Lock, .25–20, NI, Ss	1	
18	1011159	Hose, Vacuum, 1.5d X 8.3l, Clr, Blk Wire	1	
19	79381	Clamp, Hose, Wormdrive, 1.25–2.00d, .50w	2	
20	08712	Nut, Hex, Lock, M6 X 1.00, Ss, NI	1	
21	1026270	Bracket, Arm, Prop	1	
22	1026986	① Screw, Trs, .25–20 X 3.00, Phl, Ss	1	
23	578579	Spacer, 0.25b 0.88d 0.50l	1	
24	140154	Sleeve, P/M, 0.25b 0.38d 0.3l, PI	1	
25	140053	Washer, Flat, 0.28b 0.88d .12, Ss	1	
26	1026322	Bracket, Mtg, Stop	1	
27	1034731	Screw, Hex, M6 X 1.00 X 16, Ss, Sems	2	
28	01684	Washer, Flat, 0.25, Ss	2	
29	80491	Sleeve, P/M, 0.25b 0.38d 0.2l [430ss]	1	
30	06946	② Screw, Hex, M6 X 1.00 X 35, 8.8	1	

① Serial number (10000–XXXXX)

② Serial number (XXXXX–)

③ Serial number (10000–17909)

④ Serial number (17910–)

Fig. 25 - Solution Tank Group, Disk Scrub Head

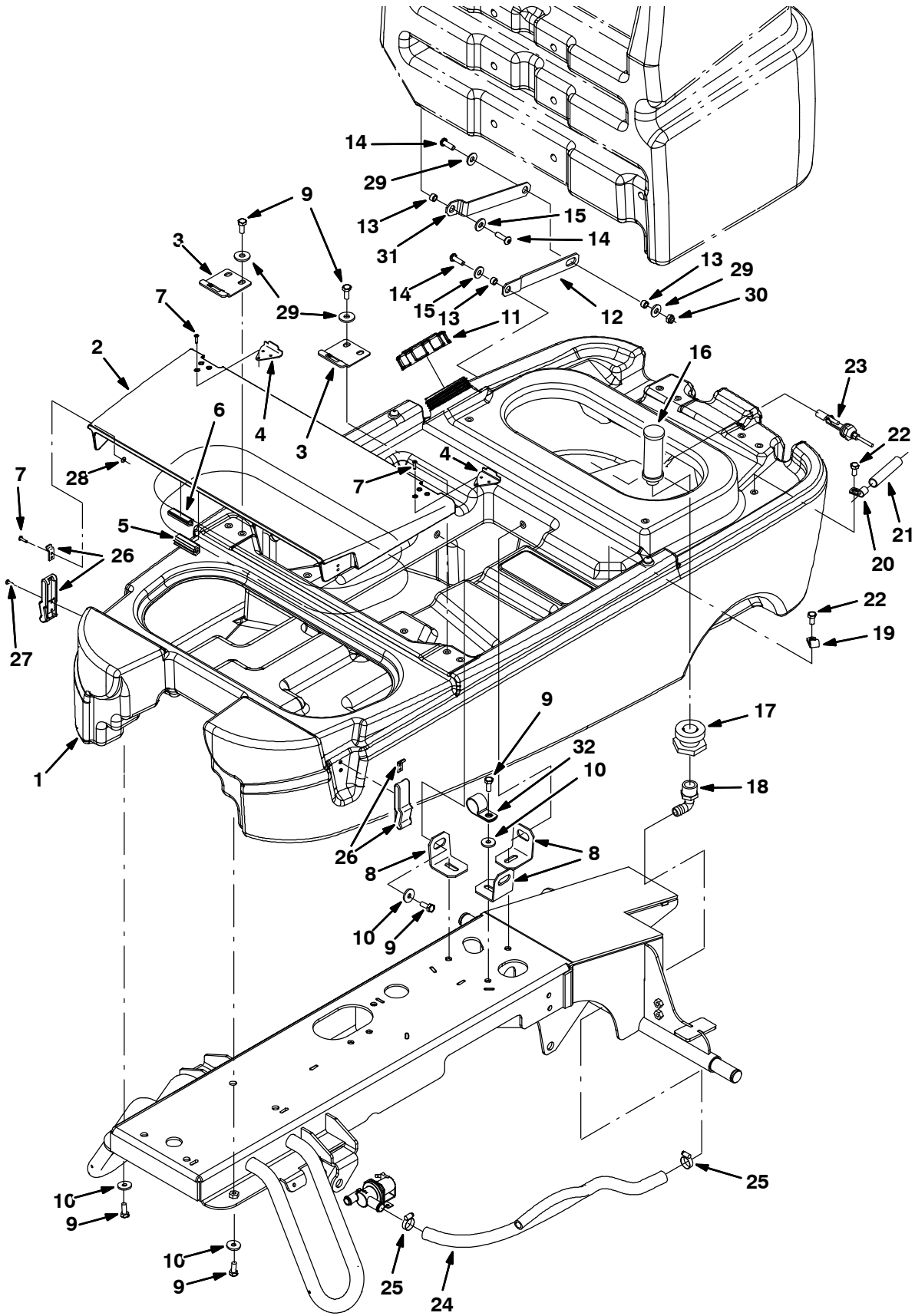

Fig. 25 – Solution Tank Group, Disk Scrub Head

Ref.	Part No.	Description	Qty.
1	9003147	Tank, Soltn, Disk, Hg, Afmkt, Ce[T7]	1
2	1012505	Cover, Tank, Soltn [T7]	1
3	1014850	Catch, Cover	2
4	1020292	Plate, Cover, Tab [T7]	2
5	1020727	Seal, Afmkt, Bulb, Clsd Cell, Adh, 8ft	1
6	1020719	Seal, Afmkt, Bulb, Clsd Cell, Adh, 8ft	1
7	1021677	Rivet, Blind, .156dx0.55x.38d, Ss	10
8	1014072	Bracket, Mtg, Tank	3
9	09740	Screw, Hex, M8 X 1.25 X 20, Ss	12
10	1017218	Washer, Flat, 0.321b 1.00d .12, Ss	8
11	1011885	Cap, Tank	1
12	1019013	Arm, Tank, Retaining	1
13	222516	Sleeve, P/M, 0.496d 0.318b 0.31l 430ss	5
14	223470	Screw, Btn, M8 X 1.25 X 25, Ss	3
15	1016435	Washer, Flat, 0.52b 0.75d .06, Stl, Blk	2
16	398770	Strainer, Soltn, 80mesh Cyl 1.3d 3.5l	1
17	377349	Fitting, Plstc, Pf12/Pf12, Bh	1
18	73468	Fitting, Plstc, E90, Bm10/Pm12	1
19	82829	Clamp, Cable, Stl, 0.63d X 0.75w, 1hole	2
20	67767	Clamp, Cable, Stl, 0.69d X 0.62w, 1h	1
21	1019879	Conduit, Nylon, .50d 3.0l	1
22	15675	Screw, Hex, M8 X 1.25 X 16, Ss	2
23	385685	Sensor, Level, Liquid, 14vdc 01a .62-11	1
24	1014825	Hose, Mold	1
25	54333	Clamp, Hose, Wormdrive, 0.31-0.88d, .31w	2
26	49800	Latch, Draw, Soft, Rbr W/ Keeper	2
27	607006	Screw, Trs, M4 X 0.70 X 12, Phl, Pl	4
28	1035394	Washer, Flat, 0.17b 0.38d .04, Ss	4
29	01685	Washer, Flat, 0.31 Ss	6
30	08713	Nut, Hex, Lock, M8 X 1.25, NI, Ss	1
31	1011853	Arm, Tank, Retaining	1
32	69234	Clamp, Cable, Stl, 1.00d X 0.75w, 1hole	1

Fig. 26 – Solution Tank Group, Cylindrical Scrub Head

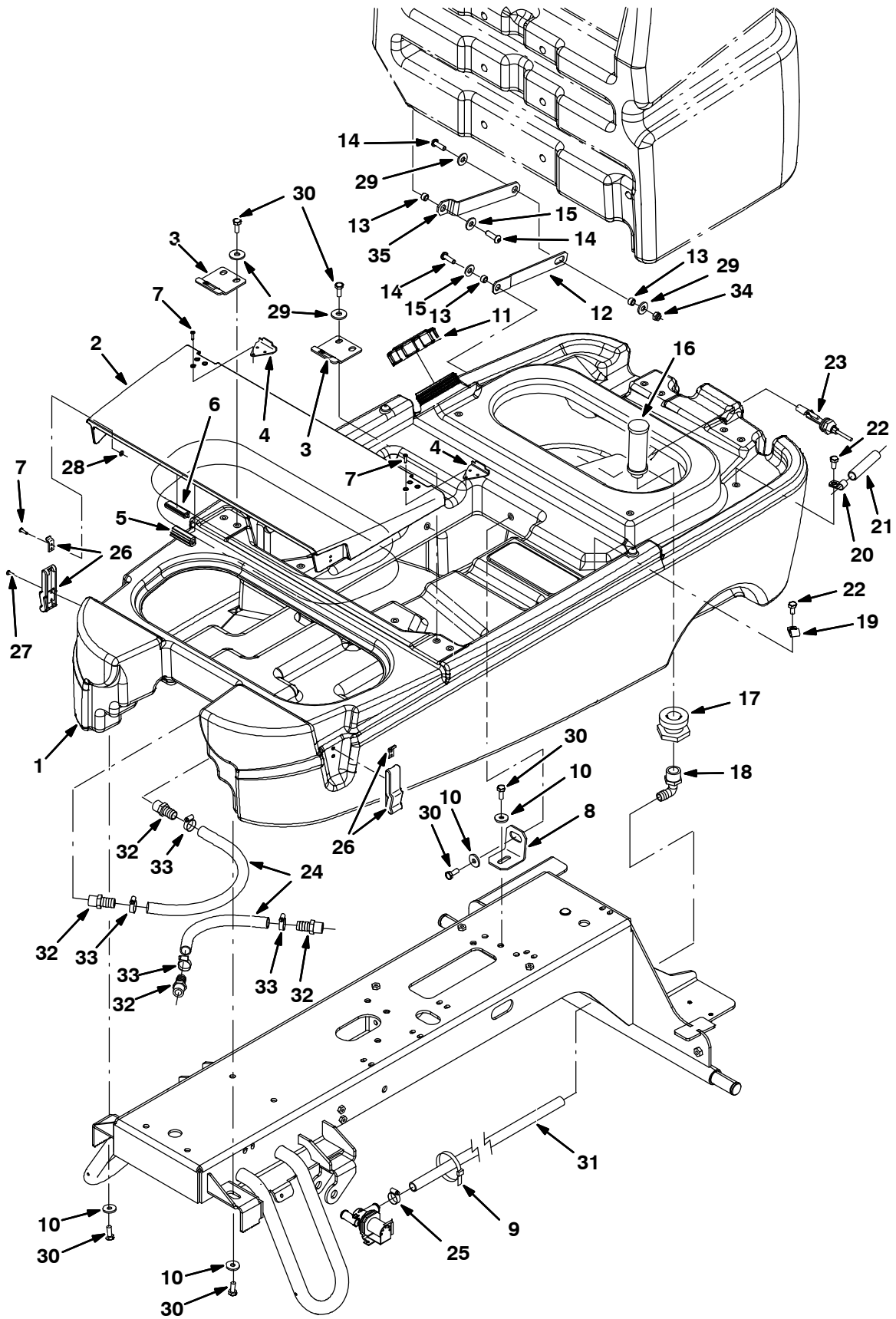

Fig. 26 – Solution Tank Group, Cylindrical Scrub Head

Ref.	Part No.	Description	Qty.
1	9003148	Tank, Soltn, Cylrcl, Hg, Afmkt, Ce[T7]	1
2	1012505	Cover, Tank, Soltn [T7]	1
3	1014850	Catch, Cover	2
4	1020292	Plate, Cover, Tab [T7]	2
5	1020727	Seal, Afmkt, Bulb, Clsd Cell, Adh, 8ft	1
6	1020719	Seal, Afmkt, Bulb, Clsd Cell, Adh, 8ft	1
7	1021677	Rivet, Blind, .156dx0.55x.38d, Ss	10
8	1014072	Bracket, Mtg, Tank	1
9	130773	Tie, Cable, Nyl, 11.0L, .14W, 3.0 Max. D	1
10	1017218	Washer, Flat, 0.321b 1.00d .12, Ss	4
11	1011885	Cap, Tank	1
12	1019013	Arm, Tank, Retaining	1
13	222516	Sleeve, P/M, 0.496d 0.318b 0.31l 430ss	5
14	223470	Screw, Btn, M8 X 1.25 X 25, Ss	3
15	1016435	Washer, Flat, 0.52b 0.75d .06, Stl, Blk	2
16	398770	Strainer, Soltn, 80mesh Cyl 1.3d 3.5l	1
17	377349	Fitting, Plstc, Pf12/Pf12, Bh	1
18	73468	Fitting, Plstc, E90, Bm10/Pm12	1
19	82829	Clamp, Cable, Stl, 0.63d X 0.75w, 1hole	2
20	67767	Clamp, Cable, Stl, 0.69d X 0.62w, 1h	1
21	1019879	Conduit, Nylon, .50d 3.0l	1
22	15675	Screw, Hex, M8 X 1.25 X 16, Ss	2
23	385685	Sensor, Level, Liquid, 14vdc 01a .62-11	1
24	1035355	Hose, Afmkt, Pvc, Clr, 0.62ld, 02Ft	2
25	63810	Clamp, Hose, Wormdrive, 0.56-1.06d, .56w	1
26	49800	Latch, Draw, Soft, Rbr W/ Keeper	2
27	607006	Screw, Trs, M4 X 0.70 X 12, Phl, Pl	4
28	1035394	Washer, Flat, 0.17b 0.38d .04, Ss	4
29	01685	Washer, Flat, 0.31 Ss	4
30	09740	Screw, Hex, M8 X 1.25 X 20, Ss	8
31	1015026	Hose, Afmkt, Pvc, Brd, 0.62id, 03ft, Clr	1
32	41440	Fitting, Plstc, Str, Bm10/Pm08	4
33	54333	Clamp, Hose, Wormdrive, 0.31-0.88D, .31W	4
34	08713	Nut, Hex, Lock, M8 X 1.25, NI, Ss	1
35	1011853	Arm, Tank, Retaining	1

Fig. 27 – Tanks Drain Group

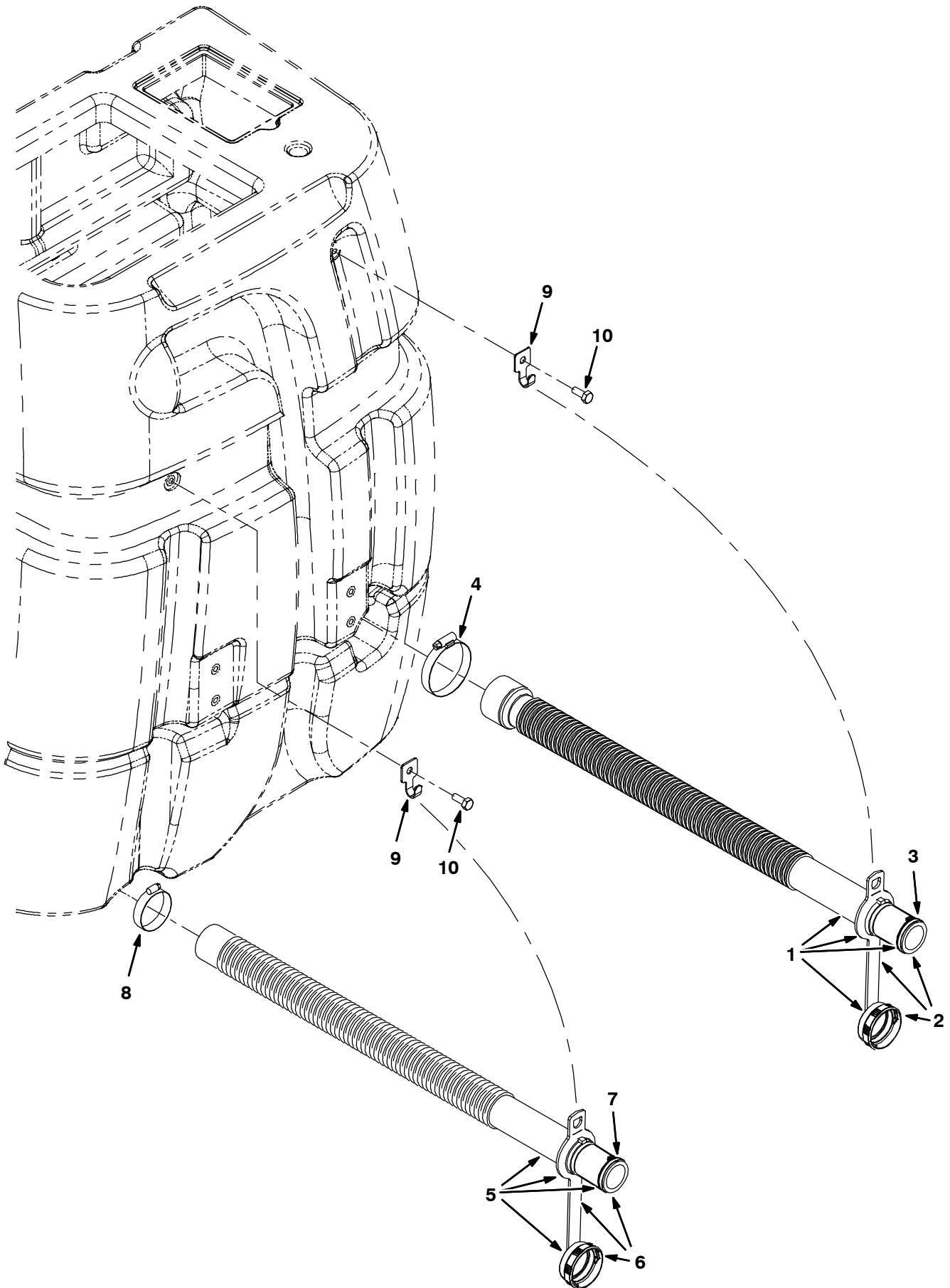

Fig. 27 – Tanks Drain Group

	Ref.	Part No.	Description	Qty.
▽	1	1014274	Hose Assy, Drain, 1.50id X 27.8l, Blk (Recovery Tank)	1
▲▽	2	1008639	Cap, Drain Assembly	1
▲▲	3	1008637	O Ring, 1.48" Id, 1.76" Od	1
	4	14432	Clamp, Hose, Wormdrive, 1.81–2.75d, .56w	1
▽	5	1014268	Hose Assy, Drain, 1.50id X 27.0l, Blk (Solution Tank)	1
▲▽	6	1008639	Cap, Drain Assembly	1
▲▲	7	1008637	O Ring, 1.48" Id, 1.76" Od	1
	8	79381	Clamp, Hose, Wormdrive, 1.25–2.00d, .50w	1
	9	222793	Clip, Hanger, Hose, .38d Hole, Ss	2
	10	09740	Screw, Hex, M8 X 1.25 X 20, Ss	2

Fig. 28 – Rear Squeegee Lift Group, Disk Scrub Head

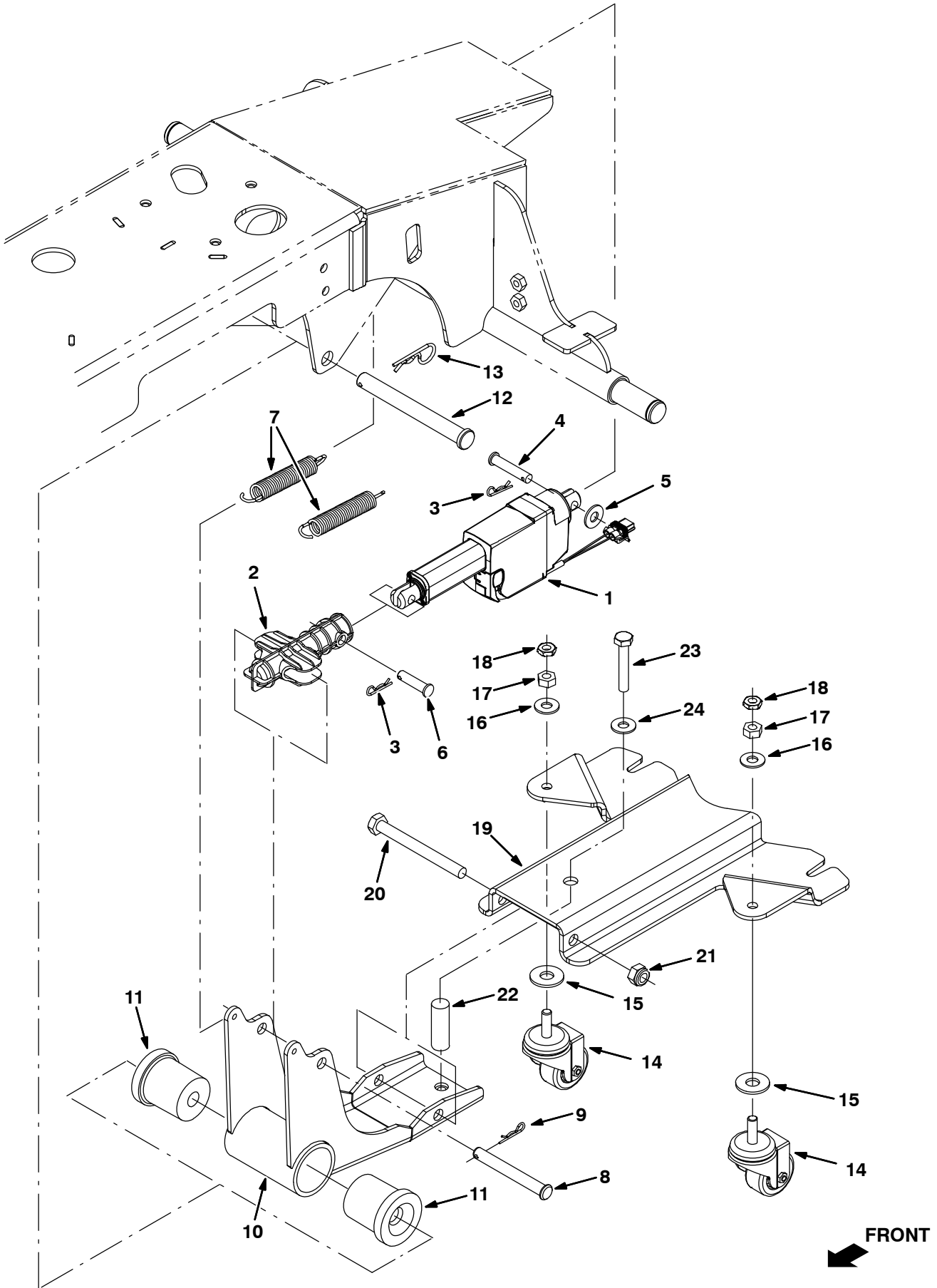

Fig. 28 – Rear Squeegee Lift Group, Disk Scrub Head

	Ref.	Part No.	Description	Qty.
▽	1	9010845	Actuator Kit, Replmt [T7/Ssr]	1
▲	2	1031028	Housing, Sqge, Spring, Actuator	1
	3	86866	Pin, Hair Cotter, 0.38 D .072 Wir	2
	4	94877	Pin, Clevis, 10d X 50l	1
	5	01686	Washer, Flat, 0.44b 1.00 .08, Ss	1
	6	1009356	Pin, Clevis , 10mm X 40l	2
	7	1016639	Spring, Extn, 0.75od X 0.11wir, 4.5l	2
	8	96184	Pin, Clevis, 12d X 100l, Pl	1
	9	86866	Pin, Cotter, Hair, 0.38d .072 Wir	1
	10	1031379	Arm Wldt, Sqge, Rear	1
	11	1013515	Bushing, Flex, Ure	2
	12	1010401	Pin, Clevis, 16d X 150l	1
	13	02942	Pin, Hair Cotter, 0.62 D .120 Wir	1
	14	1073476	Caster, Swivel, 50mmd, M10 X 30, Clr Pl	2
	15	41619	Washer, Flat, 0.56b 1.38d .11, Ss	2
	16	01686	Washer, Flat, 0.44b 1.00 .08, Ss	2
	17	07787	Nut, Hex, Std, M10 X 1.5, Ss	2
	18	32716	Nut, Hex, Jam, M10 X 1.5, Ss	2
	19	1018725	Channel, Arm, Lower Sqge	1
	20	12138	Screw, Hex, M12 X 1.75 X 120, 8.8	1
	21	09741	Nut, Hex, Lock, M12 X 1.75, NI, Ss	1
	22	1020182	Spring, Cmpr, 20mm D X 44mm L	1
	23	04417	Screw, Hex, M10 X 1.5 X 60, Ss	1
	24	01686	Washer, Flat, 0.44b 1.00 .08, Ss	1

Fig. 29 - Rear Squeegee Lift Group, Cylindrical Scrub Head

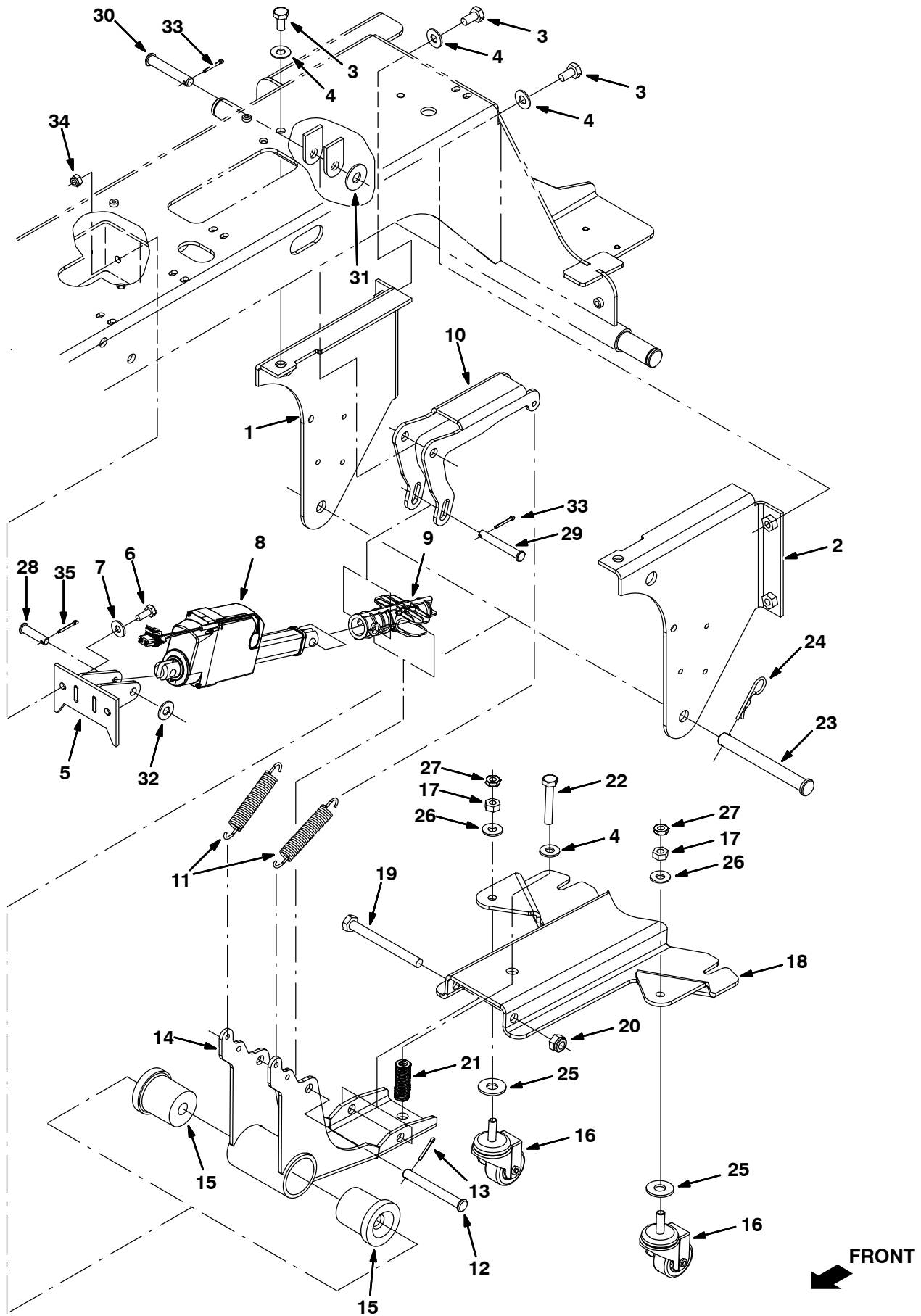

Fig. 29 – Rear Squeegee Lift Group, Cylindrical Scrub Head

Ref.	Part No.	Description	Qty.	
1	1028997	Support, Frame, Sqge	1	
2	1028998	Support, Frame, Sqge	1	
3	09291	Screw, Hex, M10 X 1.5 X 20, Ss	6	
4	01686	Washer, Flat, 0.44b 1.00d .08, Ss	7	
5	1029072	Bracket Wldt, Actuator	1	
6	09740	Screw, Hex, M8 X 1.25 X 20, Ss	2	
7	01685	Washer, Flat, 0.38b 0.88d .08, Ss	2	
▽	8	9010845	Actuator Kit, Replmt [T7/Ssr]	1
▲	9	1031028	Housing, Sqge, Spring, Actuator	1
10	1032539	Arm, Spring, Mtg	1	
11	1016639	Spring, Extn, 0.75od 0.11wir 04.5l	2	
12	1018483	Pin, Clevis, 12mmd X 100mml	1	
13	08182	Pin, Cotter, .125 X 1.00	1	
14	1032452	Arm Wldt, Sqge, Rear, Cylrcd	1	
15	1013515	Bushing, Flex, Ure	2	
16	1073476	Caster, Swivel, 50mmd, M10 X 30, Clr PI	2	
17	07787	Nut, Hex, Std, M10 X 1.50, Ss	2	
18	1018725	Channel, Arm, Lower Sqge	1	
19	12138	Screw, Hex, M12 X 1.75 X 120, 8.8	1	
20	09741	Nut, Hex, Lock, M12 X 1.75, NI, Ss	1	
21	1020182	Spring, Cmpr, 0.70od, 01.7l	1	
22	04417	Screw, Hex, M10 X 1.5 X 60, Ss	1	
23	1010401	Pin, Clevis, 16mmd X 150mml	1	
24	02942	Pin, Cotter, Hair, 0.62d .120 Wir	1	
25	41619	Washer, Flat, 0.56b 1.38d .11, Ss	2	
26	01686	Washer, Flat, 0.44b 1.00d .08, Ss	2	
27	32716	Nut, Hex, Jam, M10 X 1.5, Ss	2	
28	94877	Pin, Clevis, 10mmd X 050mml	1	
29	1032733	Pin, Clevis, 10mmd X 070mml, PI	1	
30	1032732	Pin, Clevis, 12mmd X 070mml, PI	1	
31	41619	Washer, Flat, 0.56b 1.38d .11, Ss	1	
32	01686	Washer, Flat, 0.44b 1.00d .08, Ss	2	
33	08182	Pin, Cotter, .125 X 1.00	2	
34	08713	Nut, Hex, Lock, M8 X 1.25, NI, Ss	2	
35	86866	Pin, Cotter, Hair, 0.38d .072 Wir	1	

Fig. 30 - Rear Squeegee Group, 650 mm

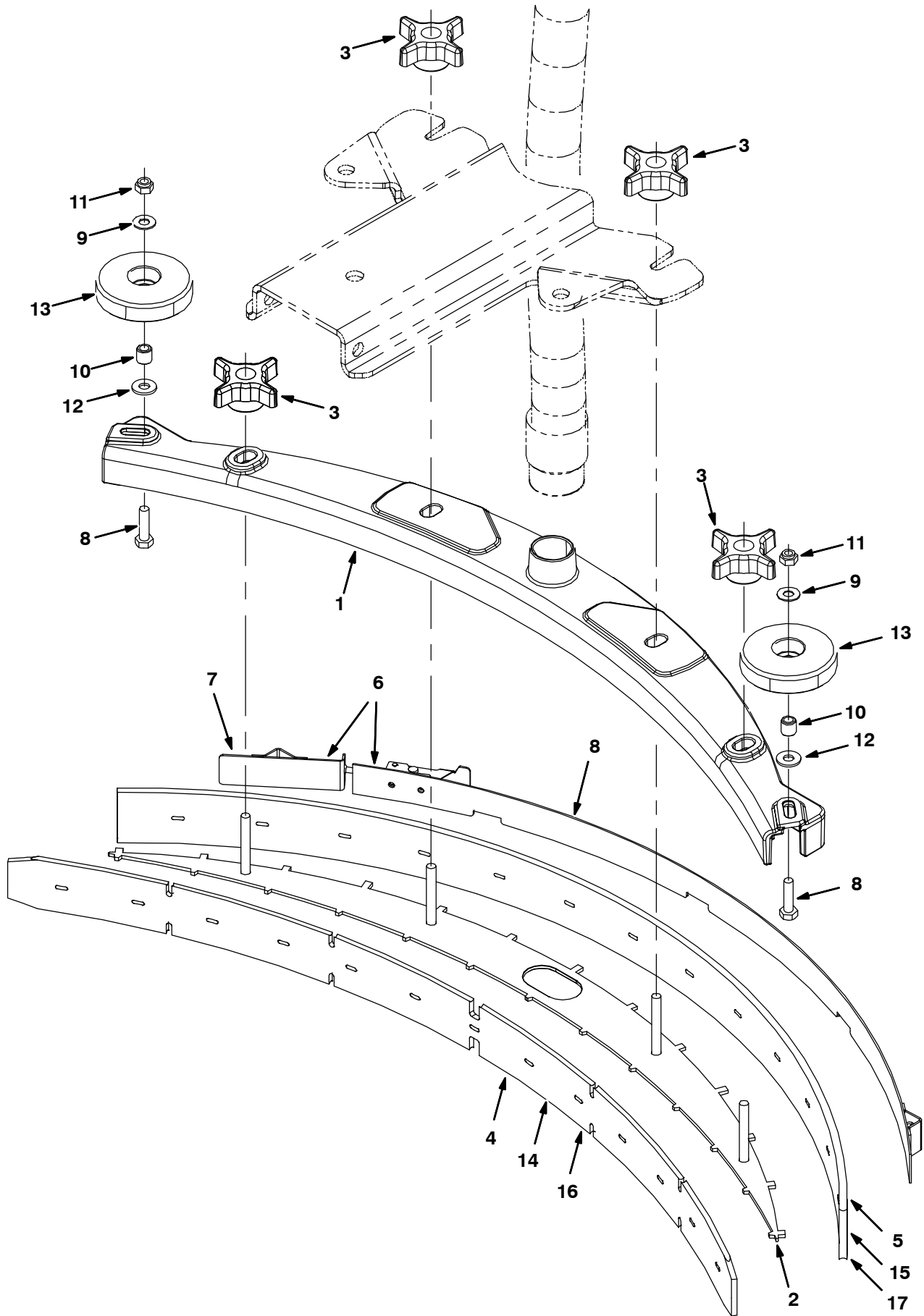

Fig. 30 – Rear Squeegee Group, 650 mm

	Ref.	Part No.	Description	Qty.
▽		9000139	Squeegee Assy Kit, 650mm, Ci [T7/Ssr]	1
▲	1	1001468	Frame, Sqge, 700mm	1
▲	2	1012934	Plate Wldt, Sqge, Retainer, 700mm	1
▲	3	1074204	Knob,Star,2.75d 4ear 1.1l M8x1.25,Thru,Y	4
▲	4	390943	Blade, Sqge, Front, 35.00l [Linx, 700mm]	1
▲	5	390942	Blade, Sqge, Rear, 37.50l Linatex[700mm]	1
▲▽	6	1245861	Strap Assy, Sqge, 700mm [T7/T7amr], Yl	1
▲▲	7	1012643	Strap Wldt, Sqge, Wedge, Ss [T3]	1
▲▲	8	1074410	Strap Assy, Sqge, 700mm [T7+]	1
▲	9	09011	Screw, Hex, M8 X 1.25 X 30, Ss	2
▲	10	140027	Washer, Flat, 0.35b 0.75d .04, Ss	2
▲	11	222460	Sleeve, P/M, 0.496d 0.318b 0.50l 430ss	2
▲	12	08713	Nut, Hex, Lock, M8 X 1.25, Ni, Ss	2
▲	13	01685	Washer, Flat, 0.38b 0.88d .08, Ss	2
▲	14	1010560	Wheel, Bmpr, 80d X 25w, Non-Marking	2
▽		391384	Squeegee Kit, 700mm, Ure	1
▲	15	391377	Blade, Sqge, Front, 35.00l Ure [700mm]	1
▲	16	391378	Blade, Sqge, Rear, 37.50l Pyu [700mm]	1
▽		391386	Squeegee Kit, 700mm, Gum	1
▲	17	390943	Blade, Sqge, Front, 35.00l [Linx, 700mm]	1
▲	18	390936	Blade, Sqge, Rear, 37.50l Gum [700mm]	1

Fig. 31 – Rear Squeegee Group, 800 mm

Ref.	Part No.	Description	Qty.
▽	9000145	Squeegee Assy Kit, 800mm, Ci [T7/Ssr]	1
▲	1 1012964	Frame, Sqge, 800mm	1
▲	2 1013395	Plate Wldt, Sqge, Retainer, 800mm	1
▲	3 1074204	Knob,Star,2.75d 4ear 1.1l M8x1.25,Thru,Y	4
▲	4 390923	Blade, Sqge, Front, 41.50l [Linx, 800mm]	1
▲	5 390922	Blade, Sqge, Rear, 44.00l Linatex[800mm]	1
▲	6 1074207	Strap Assy, Sqge, 800mm, Latch Yellow	1
▲	7 1012643	Strap Wldt, Sqge, Wedge, Ss [T3]	1
▲	8 09011	Screw, Hex, M8 X 1.25 X 30, Ss	2
▲	9 140027	Washer, Flat, 0.35b 0.75d .04, Ss	2
▲	10 222460	Sleeve, P/M, 0.496d 0.318b 0.50l 430ss	2
▲	11 08713	Nut, Hex, Lock, M8 X 1.25, Ni, Ss	2
▲	12 01685	Washer, Flat, 0.38b 0.88d .08, Ss	2
▲	13 1010560	Wheel, Bmpr, 80d X 25w, Non-Marking	2
▽	391383	Squeegee Kit, 800mm, Ure	1
▲	14 391379	Blade, Sqge, Front, 41.50l Ure [800mm]	1
▲	15 391380	Blade, Sqge, Rear, 44.0l Pyu [800mm]	1
▽	391385	Squeegee Kit, 800mm, Gum	1
▲	16 390923	Blade, Sqge, Front, 41.50l [Linx, 800mm]	1
▲	17 390934	Blade, Sqge, Rear, 44.00l Gum [800mm]	1

Fig. 32 – Circuit Board Group

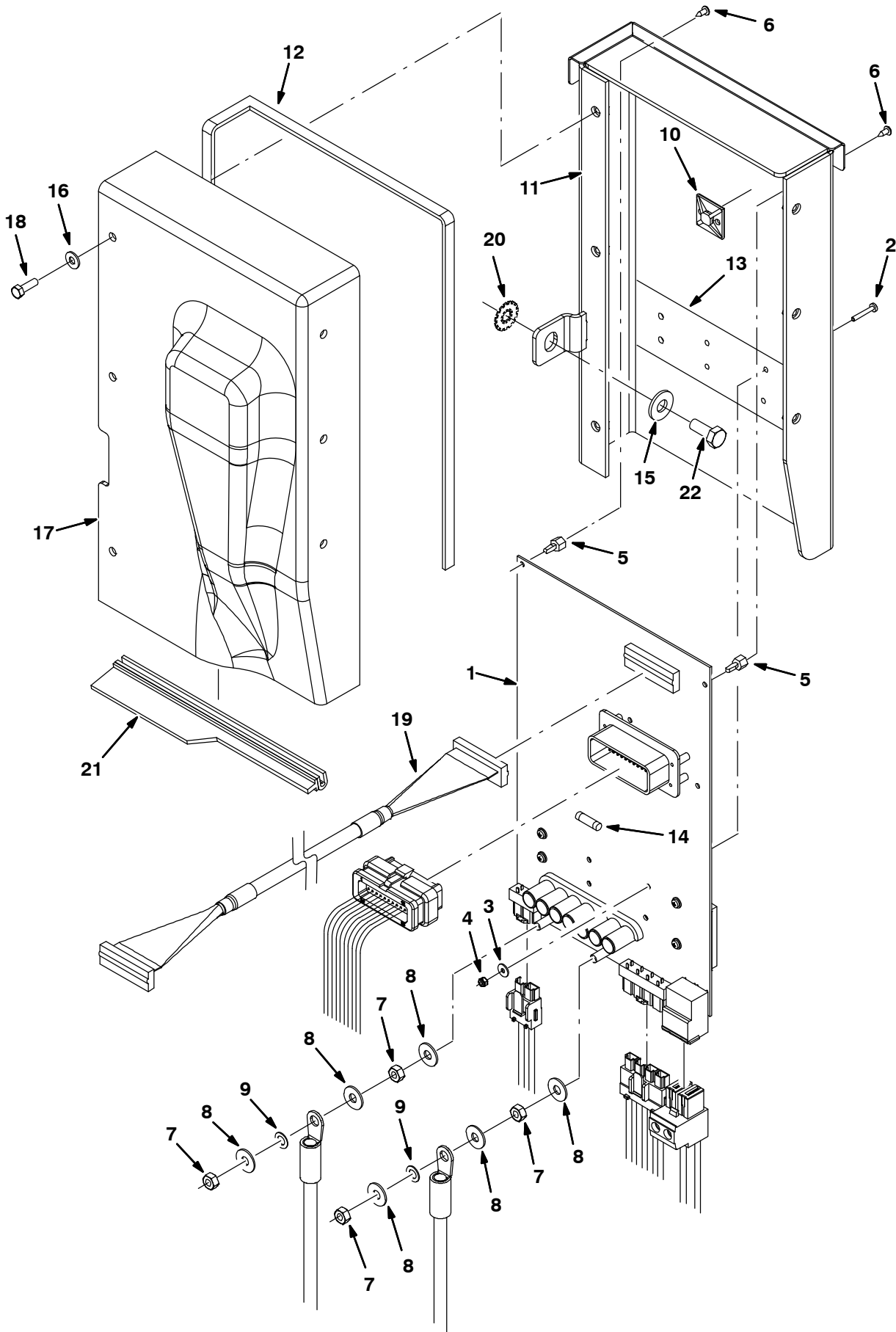

Fig. 32 – Circuit Board Group

	Ref.	Part No.	Description	Qty.
▽	1	9012711	Controller Kit, Replmt, Ci [T7 Disk]	1
▲	2	06922	Screw, Pan, M3 X 0.5 X 20, 4.8	4
▲	3	1019218	Washer, Flat, 0.14b 0.31d, Nyl	3
▲	4	579211	Nut, Hex, Lock, M3 X .5, Ss	3
▲	5	1016825	Support, Circuitboard	2
▲	6	3701.6	Screw, Pan, #06–32 X 0.38, Phl Ss Shtmtl	2
▲	7	07785	Nut, Hex, Std, M6 X 1.0, A2, Ss	4
▲	8	1057560	Washer, Flat, M6.4b, X 16d X 1 Ss	6
▲	9	32982	Washer, Lock, Int, 0.25	2
▲	10	55248	Mount, Cable Tie	1
▲	11	1017754	Panel, Wldt, Cntrl	1
▲	12	1020284	Seal, Afmkt, Rbr, Clsd, Adh, 03ft (C410217)	1
▲	13	1016816	Pad, Thermal, Heat Sink	1
▲	14	1030692	Vr, Fuse, 15a, Replmt	1
▽	1	9012712	Controller Kit, Replmt, Ci [T7 Cyl]	1
▲	2	06922	Screw, Pan, M3 X 0.5 X 20, 4.8	4
▲	3	1019218	Washer, Flat, 0.14b 0.31d, Nyl	3
▲	4	579211	Nut, Hex, Lock, M3 X .5, Ss	3
▲	5	1016825	Support, Circuitboard	2
▲	6	3701.6	Screw, Pan, #06–32 X 0.38, Phl Ss Shtmtl	2
▲	7	07785	Nut, Hex, Std, M6 X 1.0, A2, Ss	4
▲	8	1057560	Washer, Flat, M6.4b, X 16d X 1 Ss	6
▲	9	32982	Washer, Lock, Int, 0.25	2
▲	10	55248	Mount, Cable Tie	1
▲	11	1017754	Panel, Wldt, Cntrl	1
▲	12	1020284	Seal, Afmkt, Rbr, Clsd, Adh, 03ft (C410217)	1
▲	13	1016816	Pad, Thermal, Heat Sink	1
▲	14	1030692	Vr, Fuse, 15a, Replmt	1
	15	01685	Washer, Flat, 0.31 Ss	1
	16	76426	Washer, Sealing, 0.28b 0.75d Ss/Neo	6
	17	1036368	Cover, Panl, Ele, Afmkt, Na, Ce, Tj	1
	18	24199	Screw, Hex, M5 X 0.8 X 16, Ss	6
	19	1016865	Cable, Ribbon	1
	20	41141	Washer, Lock, Int–Ext, 0.31	1
	21	1019083	Seal, Cut	1
	22	09740	Screw, Hex, M8 X 1.25 X 20, Ss	1

Fig. 33 - Electrical Group

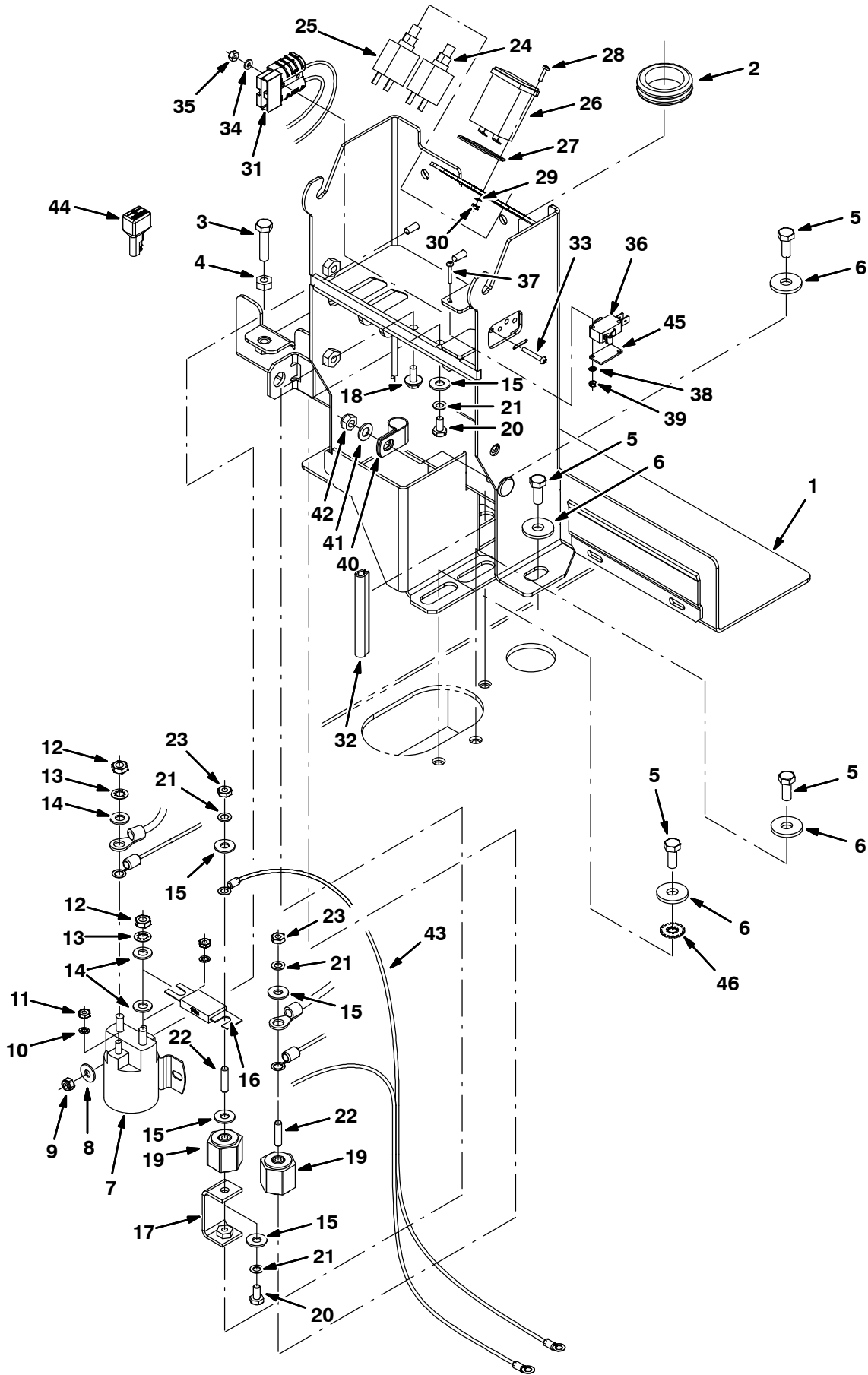

Fig. 33 – Electrical Group

Ref.	Part No.	Description	Qty.
1	1231547	② Support Wldt, Actuator [T7] (For Disk Scrub Head)	1
1	1062850	① Support Wldt, Actuator (For Disk Scrub Head) (Note: For machines built before S/N 04585 also order Grommet P/N 10632-13) (Replaced By 1231547)	1
1	1231548	② Support Wldt, Actuator [T7 Cyl] (For Cylindrical Scrub Head)	1
1	1021531	① Support Wldt, Actuator (For Cylindrical Scrub Head) (Replaced By 1231548)	1
2	10632-13	Grommet, Rbr, 1.50id, F/1.8h, .19 Matl	1
3	09023	Screw, Hex, M8 X 1.25 X 35, Ss, Fl	1
4	07786	Nut, Hex, Std, M8 X 1.25, Ss	1
5	09740	Screw, Hex, M8 X 1.25 X 20, Ss	5
6	1017218	Washer, Flat, 0.321b 1.00d .12, Ss	5
7	02424	Relay, 24vdc, 100a, Sp N/O [White]	1
8	01684	Washer, Flat, 0.25 Ss	2
9	08712	Nut, Hex, Lock, M6 X 1.0, Ss, NI	2
10	07514	Washer, Lock, Int, #10, Ss	2
11	01689	Nut, Hex, Std, #10-32, Ss	2
12	20170	Nut, Hex, Jam, .31-24	2
13	32984	Washer, Lock, Int, .31	2
14	39349	Washer, Flat, 0.31 Sae	3
15	32490	Washer, Flat, 0.25 Std	5
16	86379	Fuse, .88 X 3.2l 100a 125vac	1
17	1018546	Bracket, Stand-Off (For Disk Scrub Head)	1
18	1034731	Screw, Hex, M6 X 1.00 X 16, Ss, Sems	1
19	76062	Insulator, Panel & Switchboard	2
20	58670	Screw, Hex, .25-20 X 0.50, NI	2
21	32982	Washer, Lock, Int, 0.25	4
22	1017807	Rod, Thrld, Full, .25-20 01.0l	2
23	32520	Nut, Hex, Jam, .25-20	2
24	383720	Circuitbreaker, 5.0a	1
25	383722	Circuitbreaker, 15.0a	1
26	377433	Gauge, Hourmeter, 12-60vdc, Analog [10k]	1
27	222683	Gasket, Hourmeter	1
28	09146	Screw, Pan, M3 X 0.5 X 12, 4.8	2
29	39658	Washer, Lock, Int, #04	2
30	01754	Nut, Hex, Std, M3 X 0.5, 8	2
31	391915	Harness, Chrgr [T7] (Off-Board Charger Model w/out Iris Telemetry)	1
32	1020168	Molding, Afmkt, Trim, Pvc, .08-.11, 1ft	1
33	25005	Screw, Pan, #06-32 X 1.00, 1	2
34	19064	Washer, Flat, #06 (Off-Board Charger Model w/out Iris Telemetry)	2
35	75939	Nut, Hex, Lock, #06-32, NI (Off-Board Charger Model w/out Iris Telemetry)	2
36	600437	Switch, Snap Actn, 250vac 16a (Off-Board Charger Model w/out Iris Telemetry)	1
37	06922	Screw, Pan, M3 X 0.5 X 20, 4.8	2
38	39658	Washer, Lock, Int, #04 (Off-Board Charger Model w/out Iris Telemetry)	2
39	01754	Nut, Hex, Std, M3 X 0.5, 8 (Off-Board Charger Model w/out Iris Telemetry)	2
40	69234	Clamp, Cable, Stl, 1.00d X 0.62w, 1h	1
41	01685	Washer, Flat, 0.31 Ss	1
42	08713	Nut, Hex, Lock, M8 X 1.25, NI, Ss	1
43	391916	Harness, Power, [T7]	1
44	222290	Diode, Ele, Plug	2
45	601359	Plate, Backing, Switch (Off-Board Charger Model w/out Iris Telemetry)	1
46	41141	Washer, Lock, Int-Ext, 0.31	1

① Serial number (00001-12694)

② Serial number (12695-)

Fig. 34 – Electrical Schematic, Standard, FaST & ec-H2O Models (S/N 12695-)

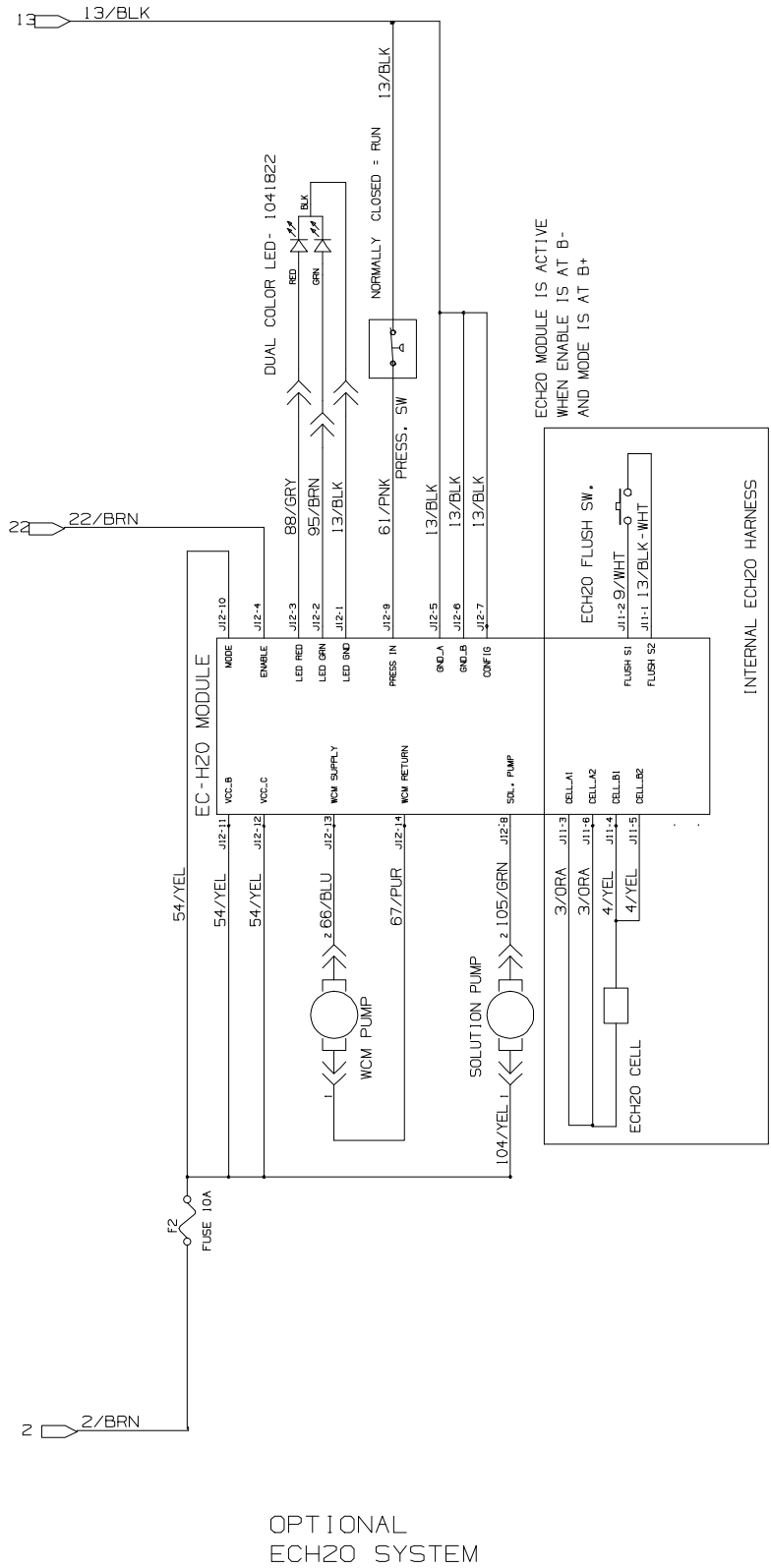

OPTIONAL
ECH2O SYSTEM

Fig. 34 – Electrical Schematic, Standard, FaST & ec-H2O Models (S/N 12695-)

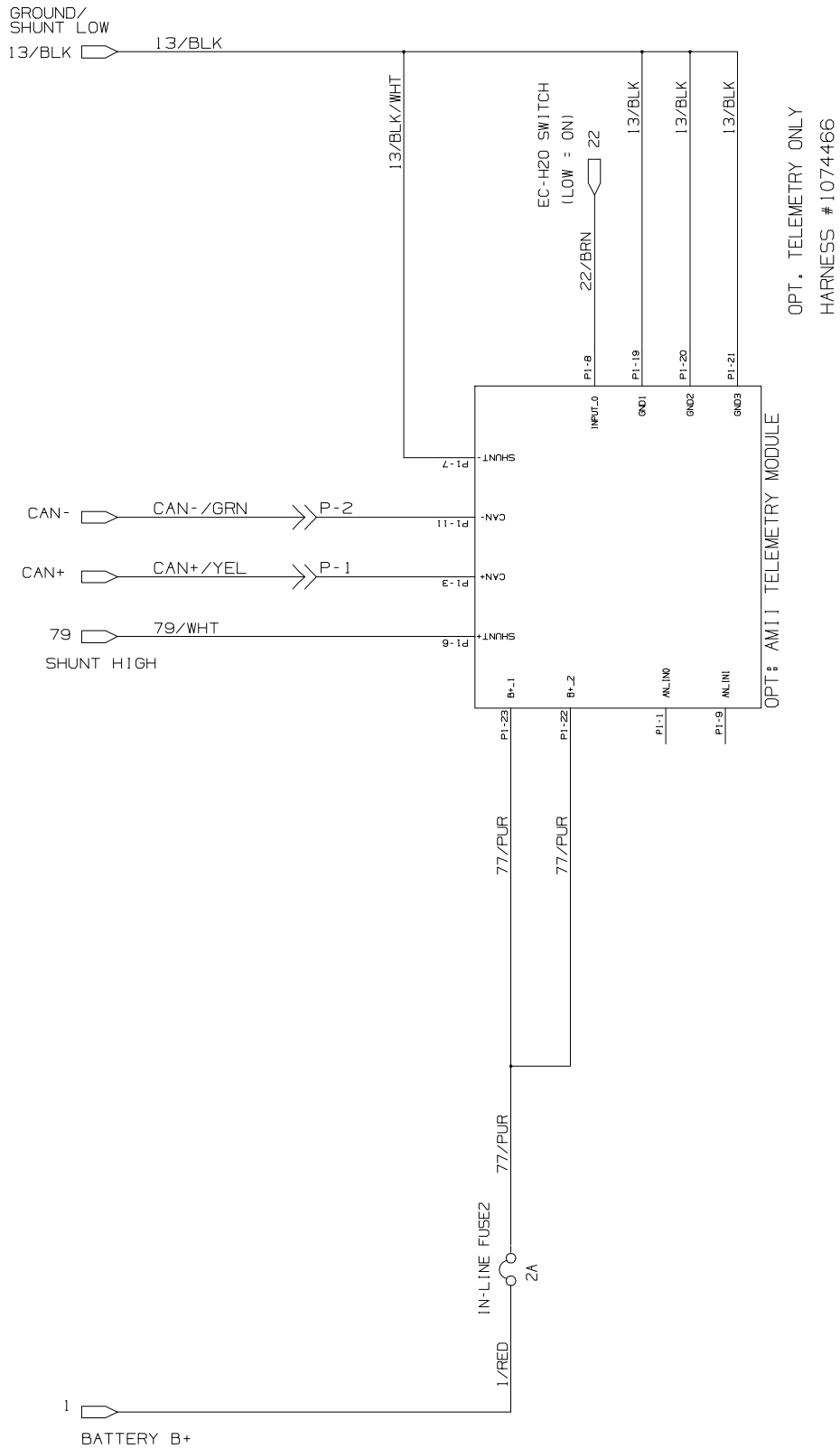

OPTIONAL :
TELEMETRY ONLY

Fig. 35 - Electrical Schematic, Standard, FaST & ec-H2O Models (S/N 11000-12694)

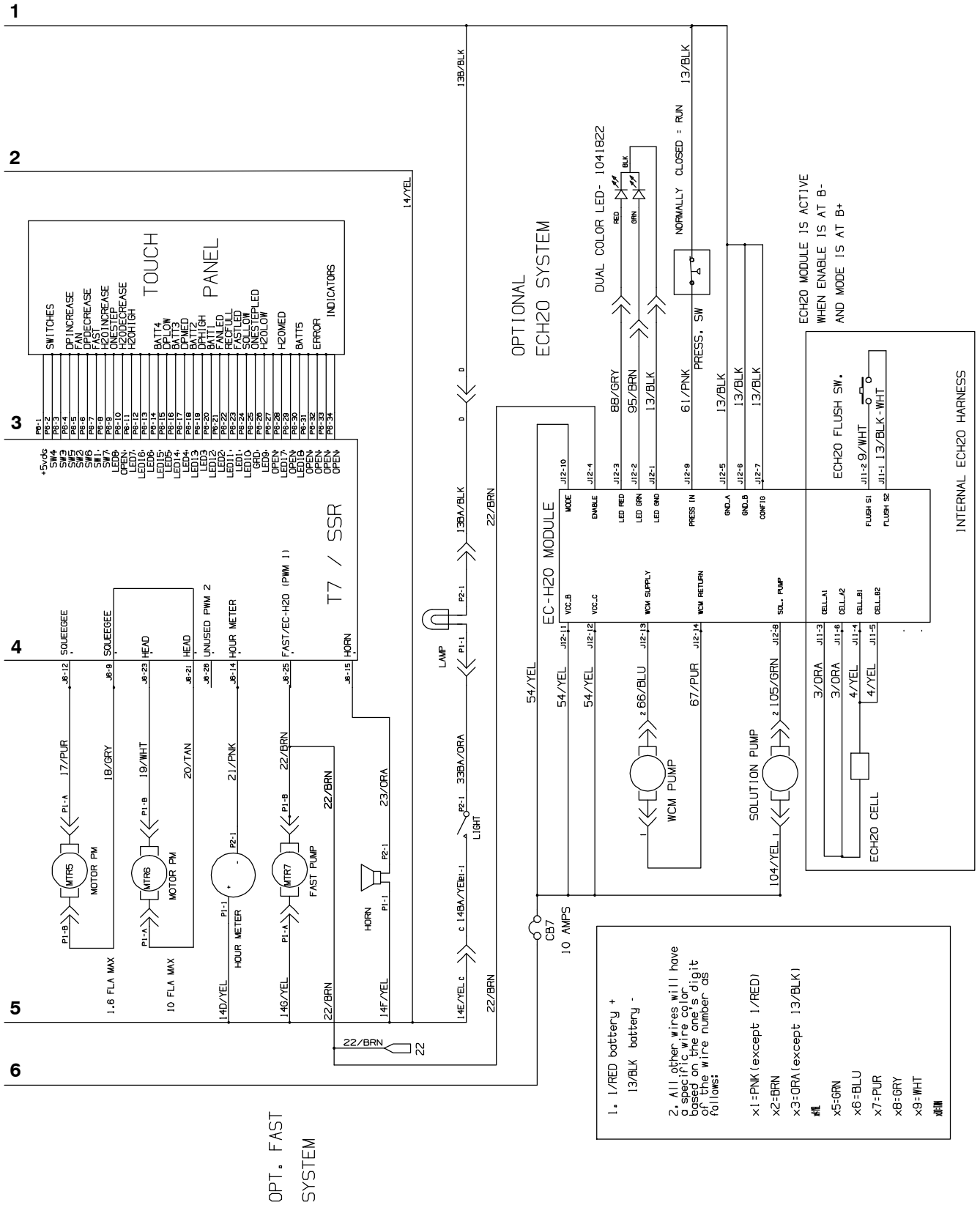
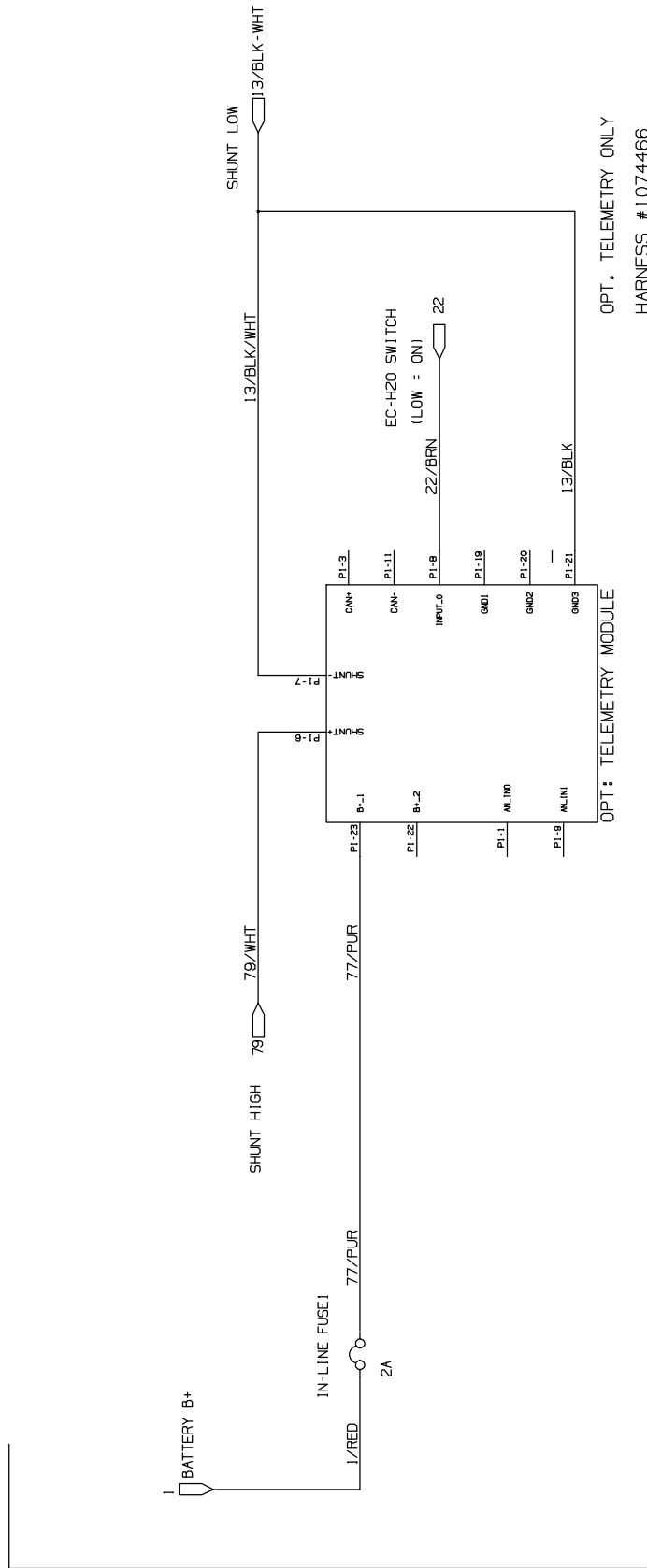

Fig. 35 – Electrical Schematic, Standard, FaST & ec-H2O Models (S/N 11000–12694)



OPTIONAL :
TELEMTRY ONLY

1074196_D

Fig. 36 – Electrical Schematic, Standard & FaST Model (S/N 10000–10999)

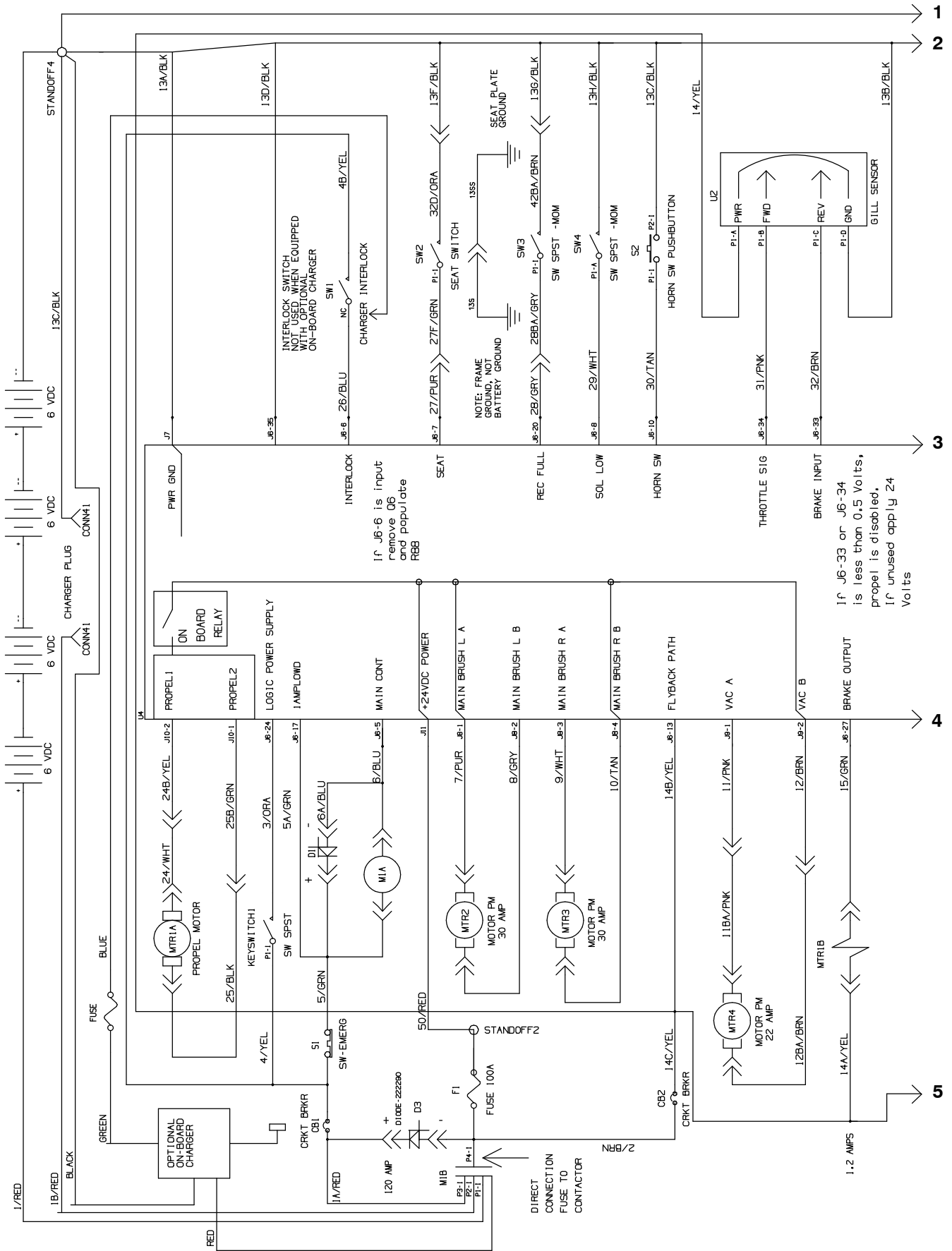

1053088

Fig. 36 – Electrical Schematic, Standard & FaST Model (S/N 10000–10999)

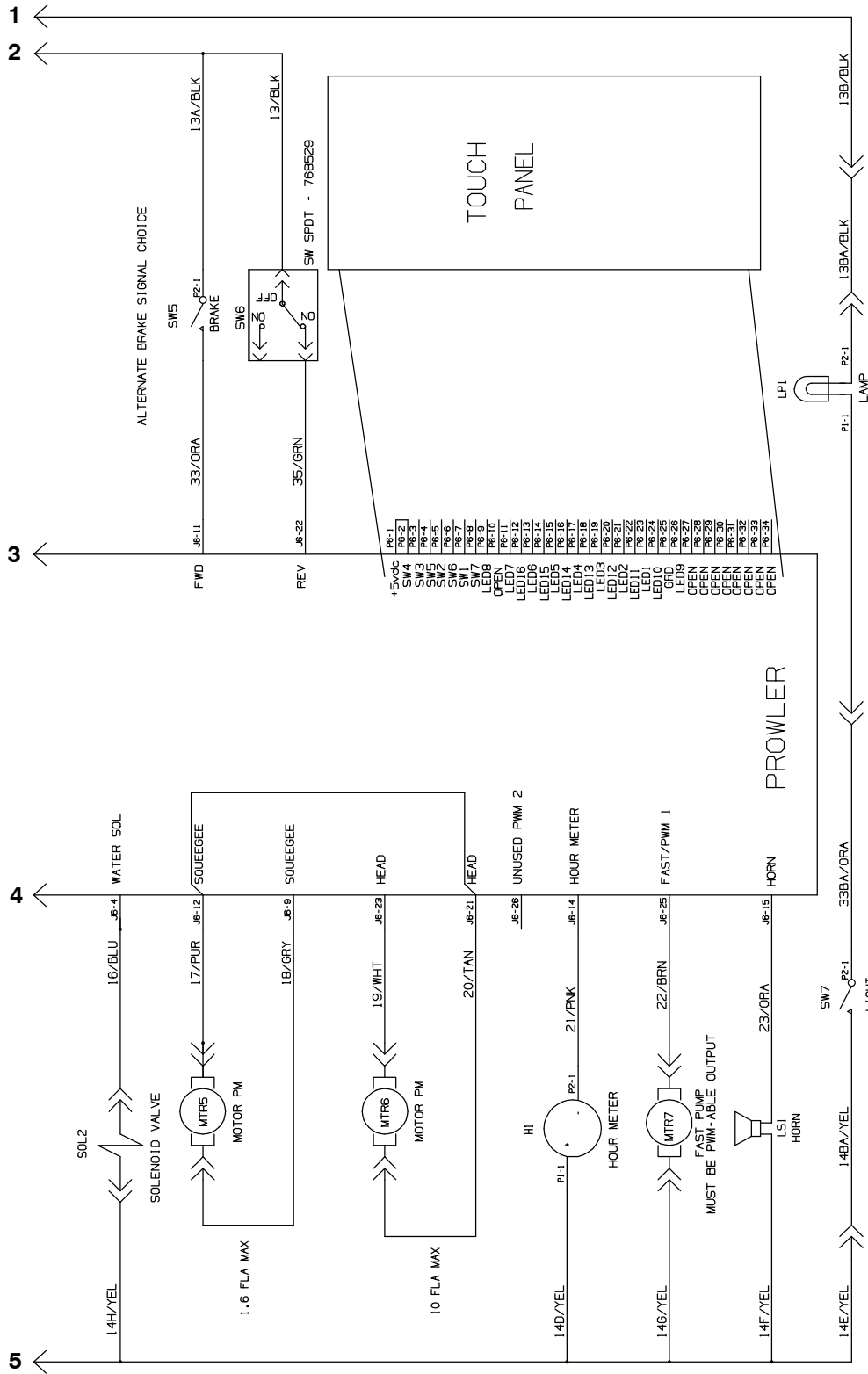

1. 1/RED and 13/BLK will remain as before.
2. All other wires will have a specific wire color based on the one's digit of the wire number as follows:
 - x1=PNK (except 1/RED)
 - x2=BRN
 - x3=ORA (except 13/BLK)
 - x4=YEL
 - x5=GRN
 - x6=BLU
 - x7=PUR
 - x8=GRY
 - x9=WHT
 - x10=TAN

Fig. 37 - Electrical Schematic, *ec-H2O* Model (S/N 10000-10999)

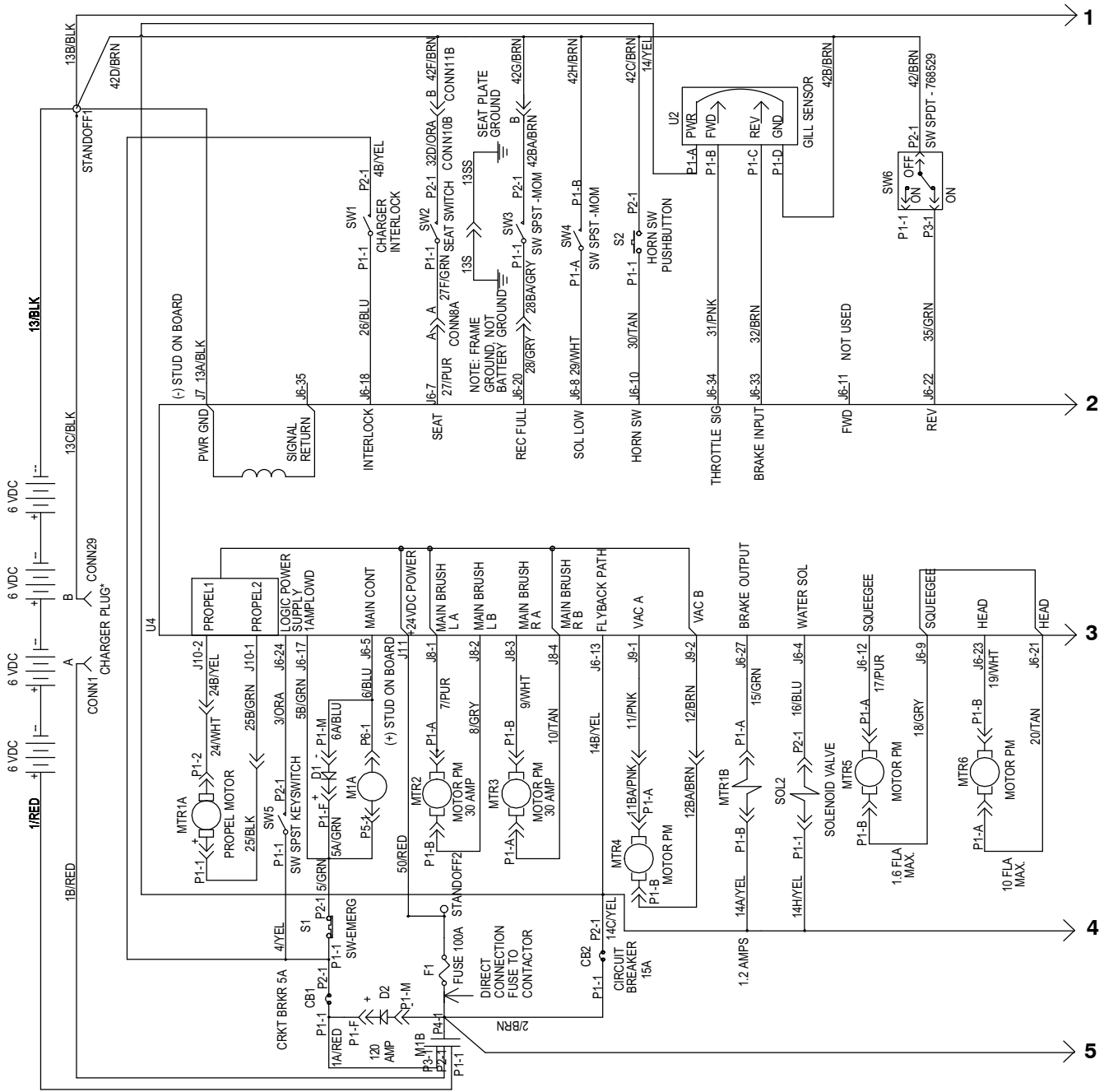

1054311

Fig. 37 – Electrical Schematic, ec-H2O Model (S/N 10000–10999)

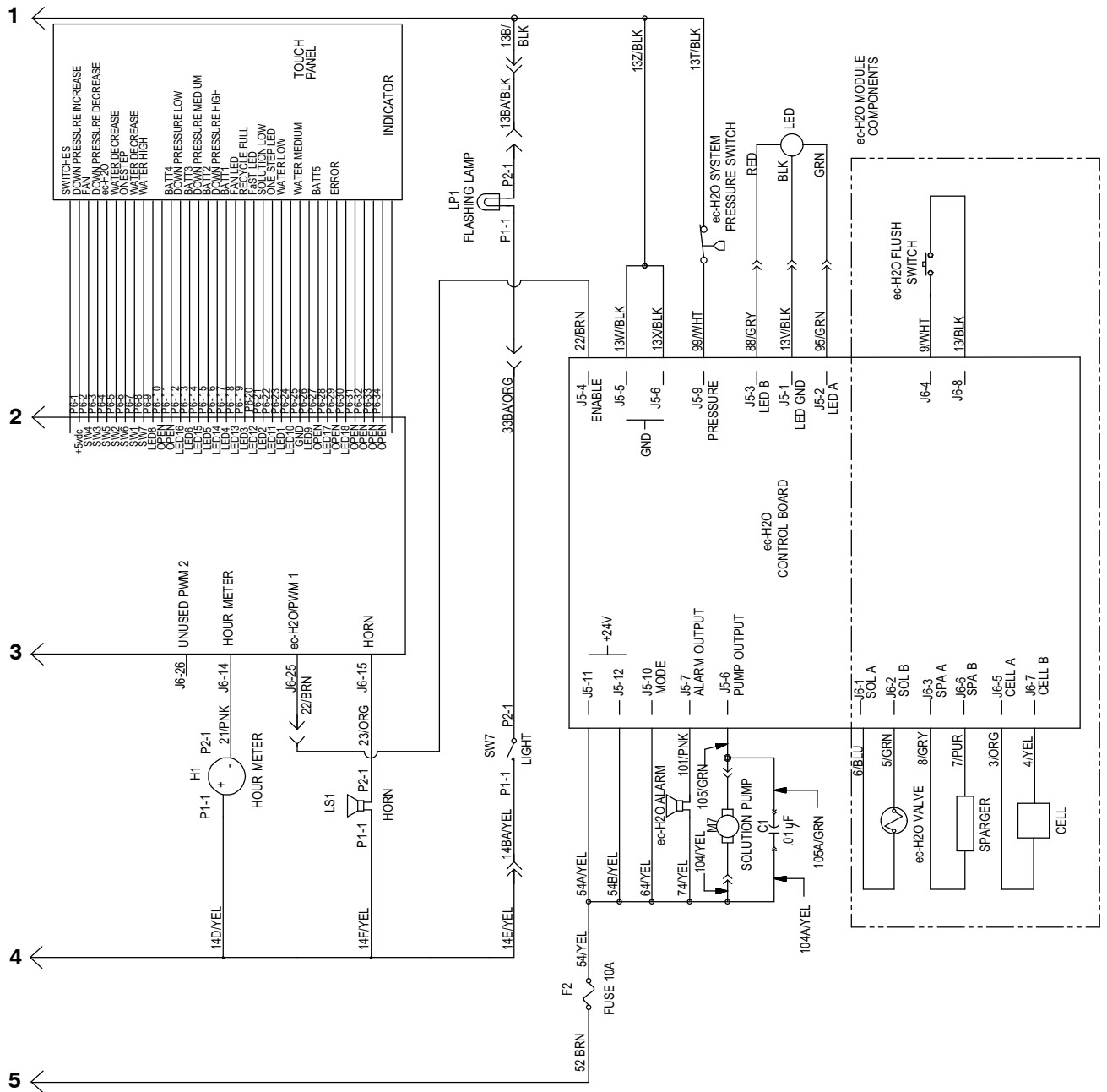
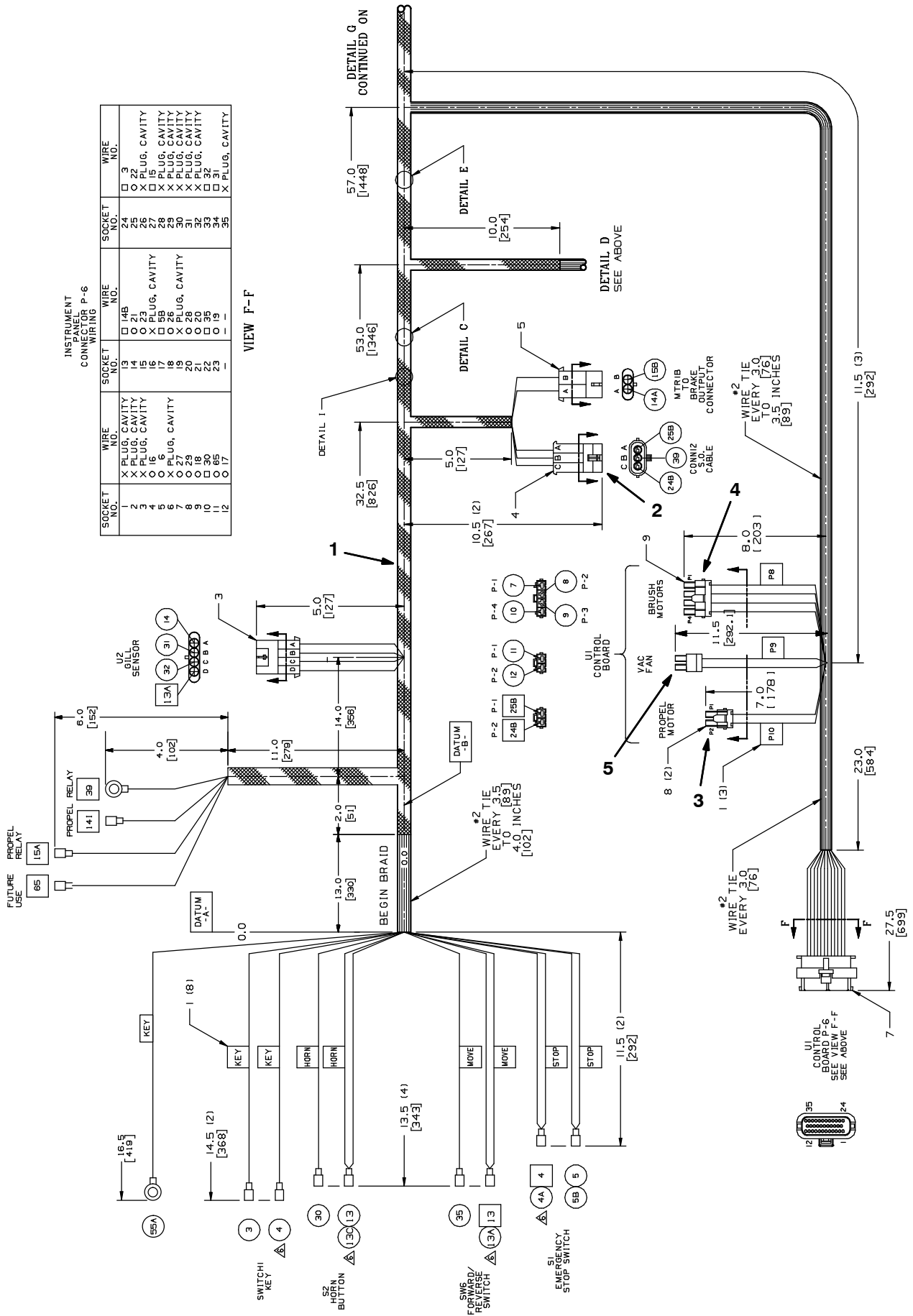
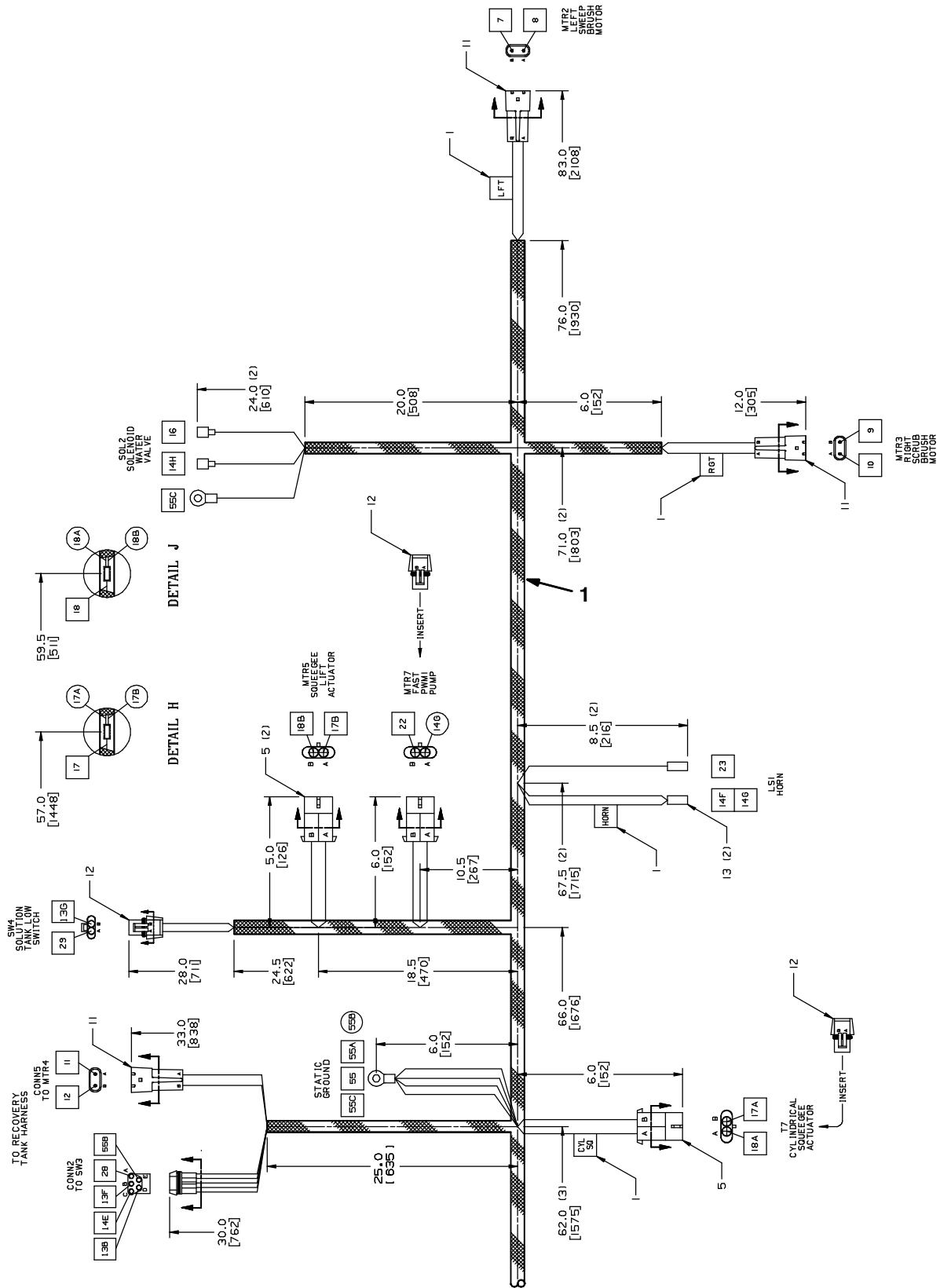

Fig. 38 - Wire Harnesses Group, Main (S/N 15418-)



1076634_01

Fig. 38 – Wire Harnesses Group, Main (S/N 15418-)



1076634_01

Ref.	Part No.	Description	Qty.
▽	1	1076634 [1] Harness, Main [T7, Emea]	1
▲	2	1047189 Connector, Mal, 3 Cav [Mp630]	1
▲	3	1076631 [1] Harness, Ele, Connector	1
▲	4	1051629 Connector, Fem, 4 Cav [Molex]	1
▲	5	1076630 [1] Harness, Ele [Vac Fan Euro Conn. Repl.]	1

[1] Serial number (15418-)

Fig. 39 – Wire Harness Group, Main (S/N 10000–15417)

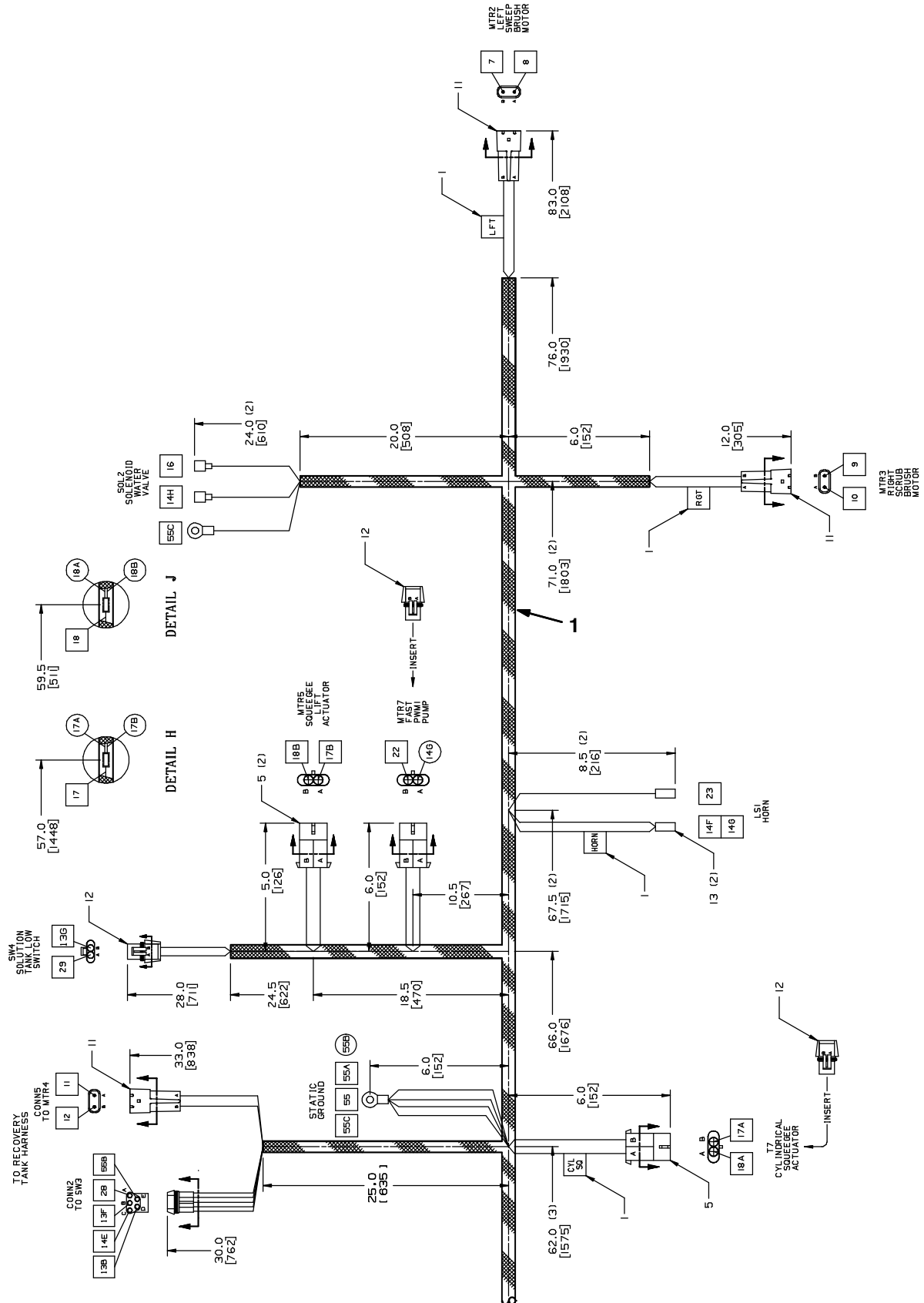

1073347

Ref.	Part No.	Description	Qty.
▽	1 1073347	1 [1] Harness, Main [T7] (Replaced by 9020706)	1
▲	2 1047189	Connector, Mal, 3 Cav [Mp630]	1
▲	3 1013835	1 [1] Connector Body, Fem, 2 Recept.[Molex]	2
▲	4 1051629	Connector, Fem, 4 Cav [Molex]	1

[1] Serial number (10000–15417)

Fig. 40 - Wire Harness Group, Tank

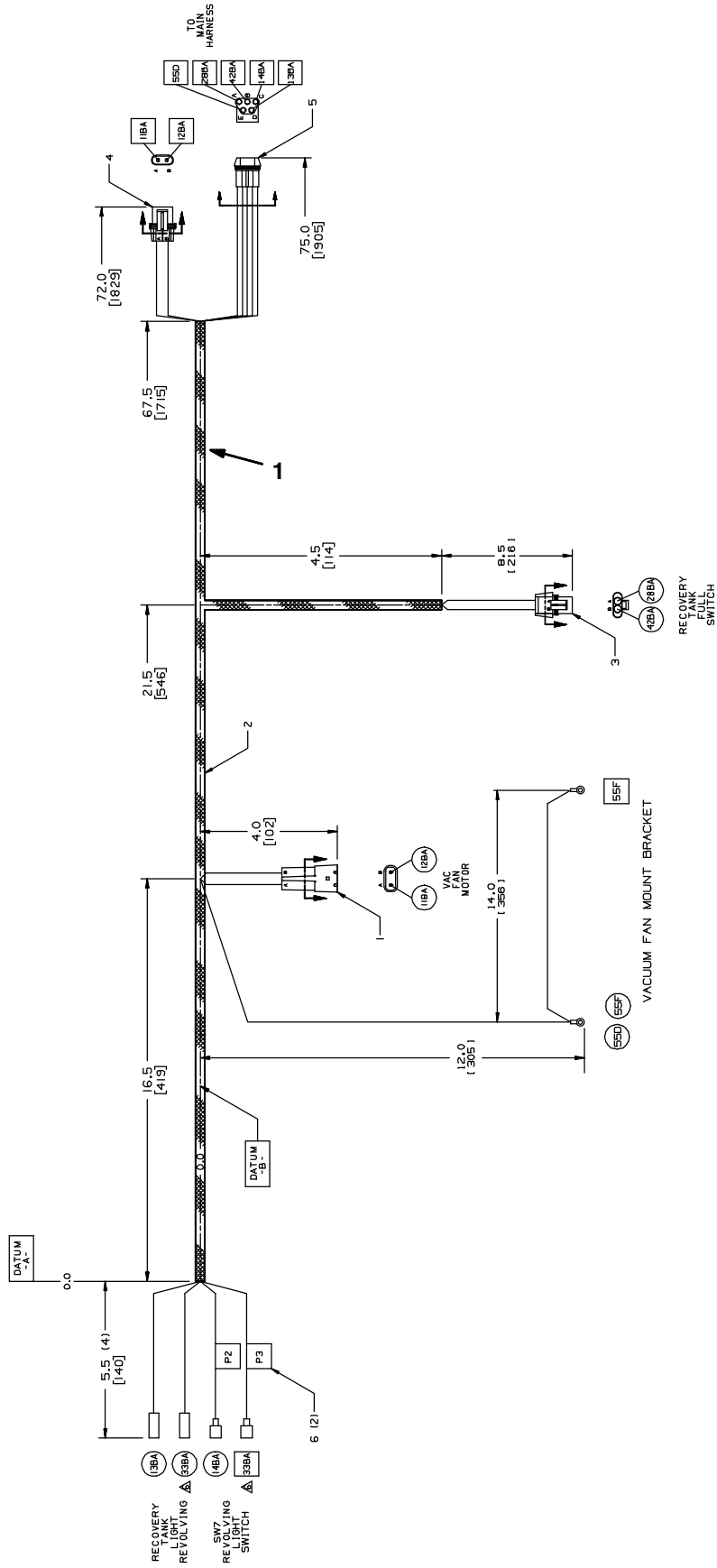

Ref.	Part No.	Description	Qty.
1	1073338	Harness, Tank [T7]	1

Fig. 41 – Wire Harnesses Group, ec-H2O NanoClean (S/N 11000-)

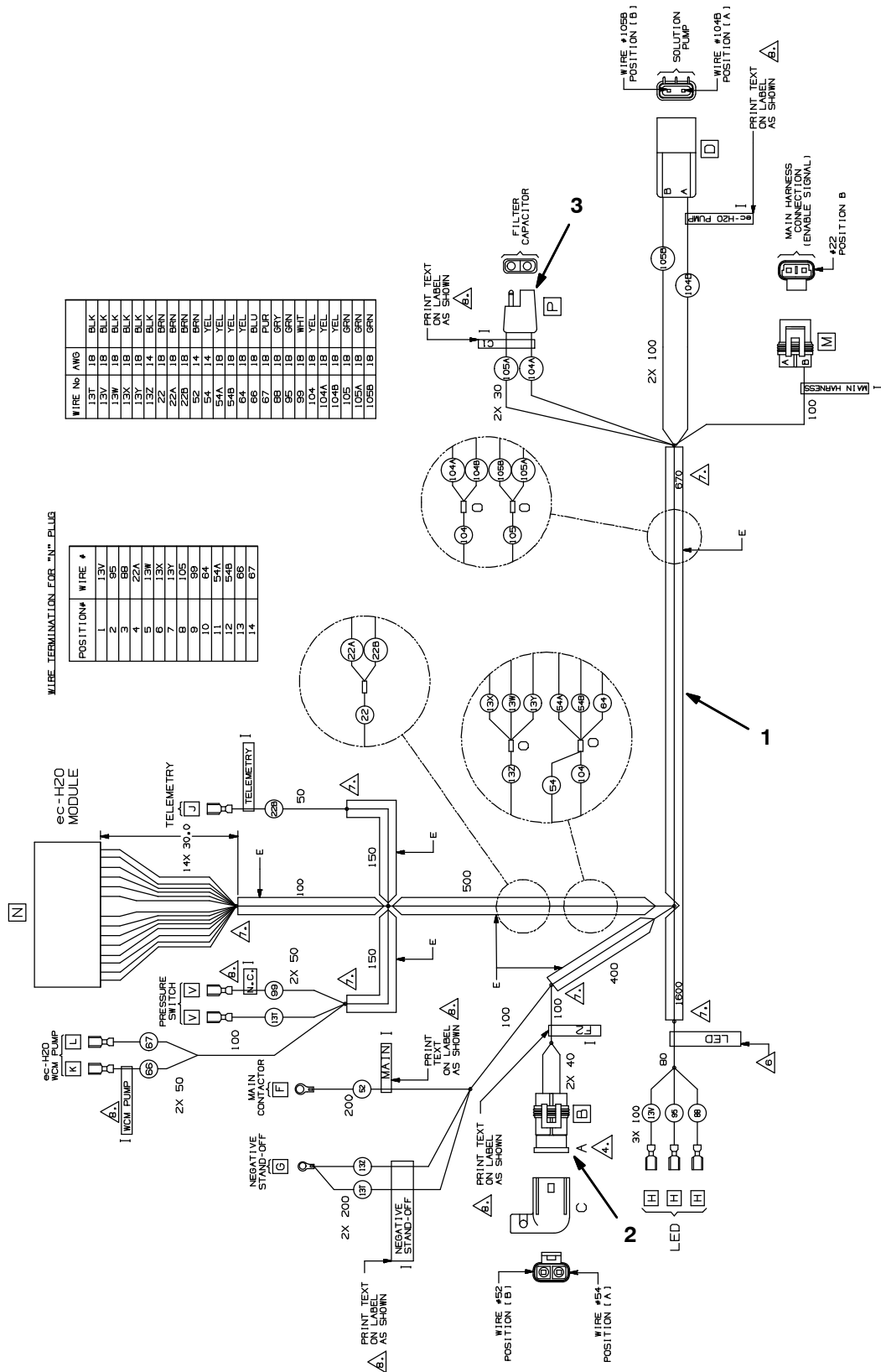

Ref.	Part No.	Description	Qty.
1	1074380	② Harness Assy, Wire [T7 Ec-H2o P3 Ce G2]	1
2	1047470	Fuse, Blade, 010a, 32vdc, Red	1
3	1040868	Capacitor, Plug [.01 Uf, 200v]	1

② Serial number (11000-)

Fig. 42 – Wire Harnesses Group, ec-H2O (S/N 10000–10999)

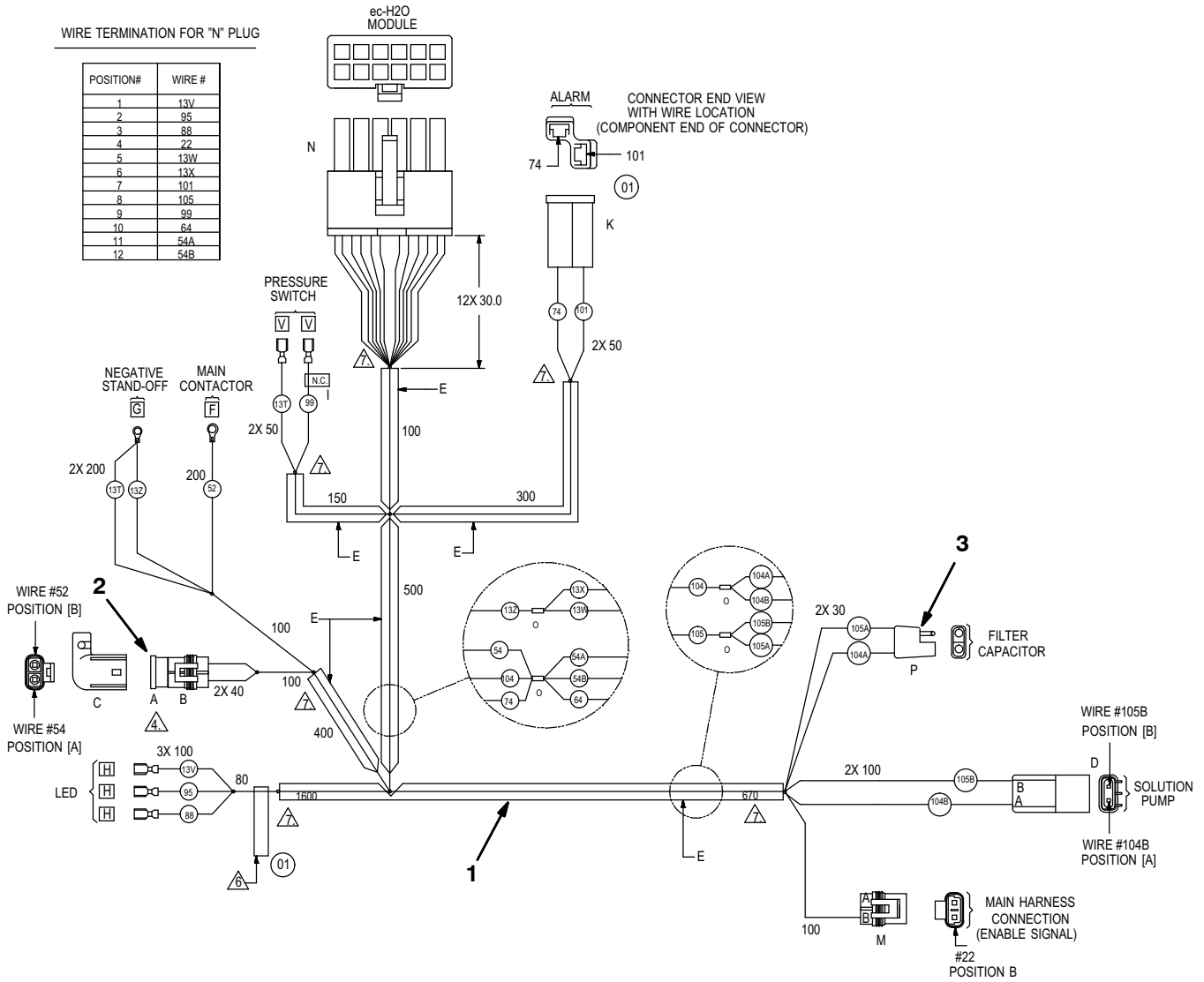

1050394

Ref.	Part No.	Description	Qty.
1	1051053	[1] Harness Assy, Wire [T7 Ec-H2o, P3 Ce]	1
2	1047470	Fuse, Blade, 010a, 32vdc, Red	1
3	1040868	Capacitor, Plug [.01 Uf, 200v]	1

[1] Serial number (10000–10999)

Fig. 43 – Wire Harnesses Group, *ec-H2O* NanoClean Main Control Board (S/N 11000-)

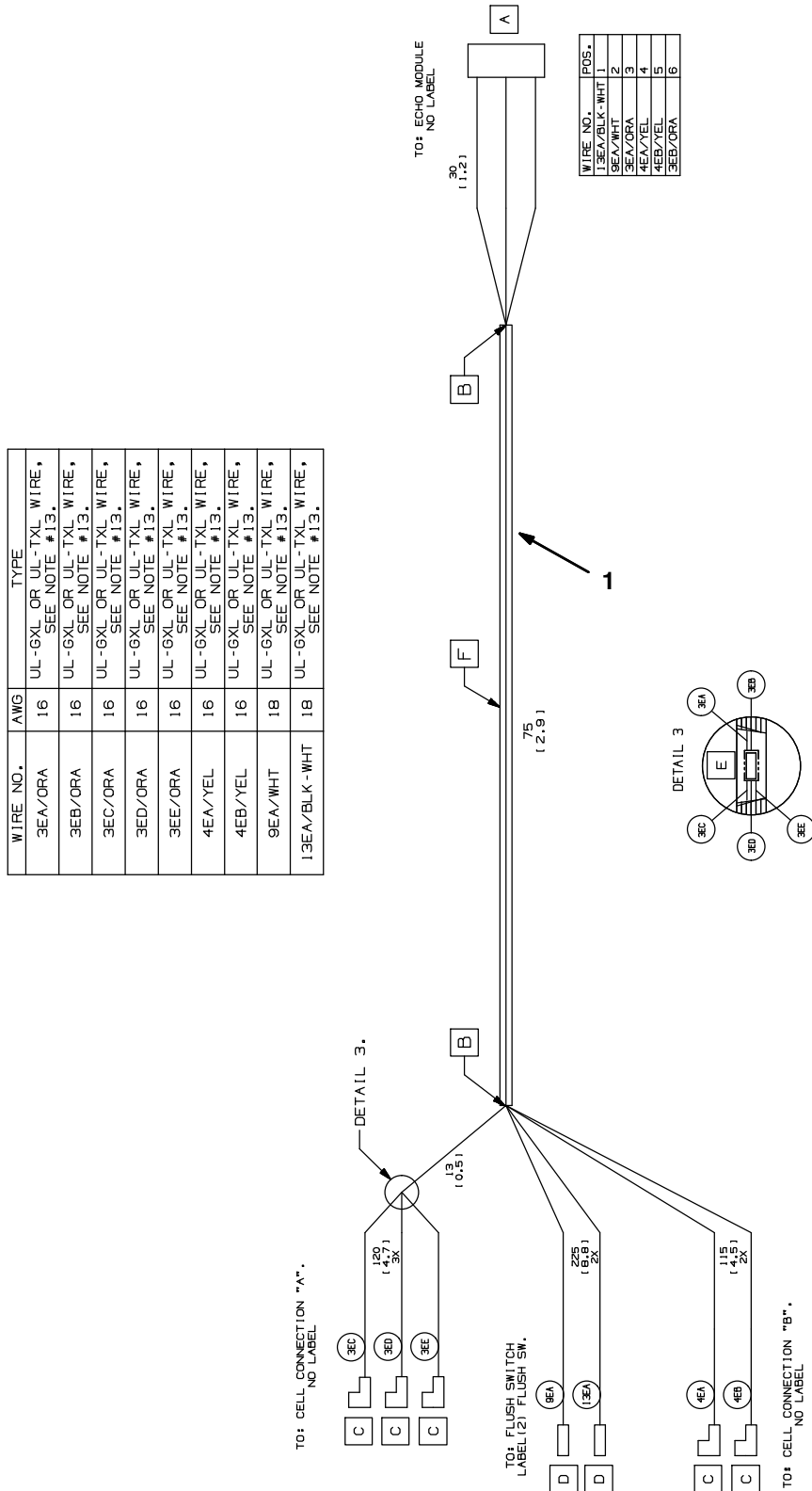

Ref.	Part No.	Description	Qty.
1	1073286	② Harness, Ele, Module B2 [Ec-H2o]	1

② Serial number (11000-)

Fig. 44 – Wire Harnesses Group, ec-H2O Main Control Board (S/N 10000–10999)

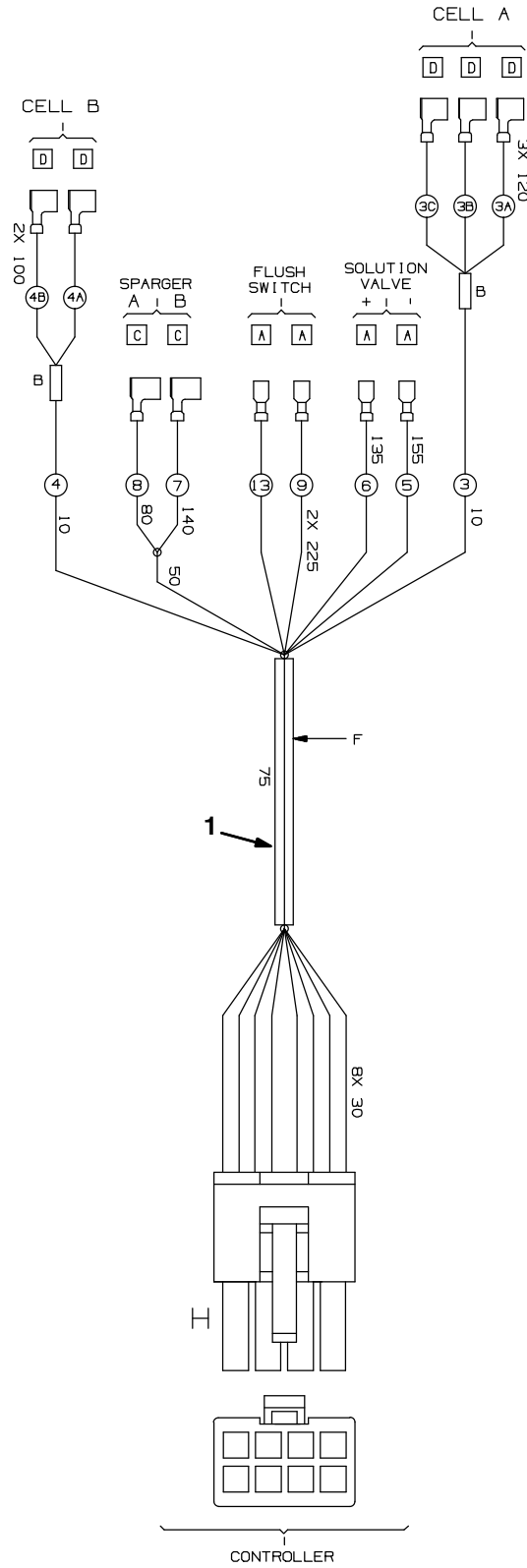

Ref.	Part No.	Description	Qty.
1	1049489	[1] Harness, Main,Controlboard[Ec-H2o 5cell]	1

[1] Serial number (10000–10999)

Fig. 45 - Wire Harnesses Group, Iris Telemetry

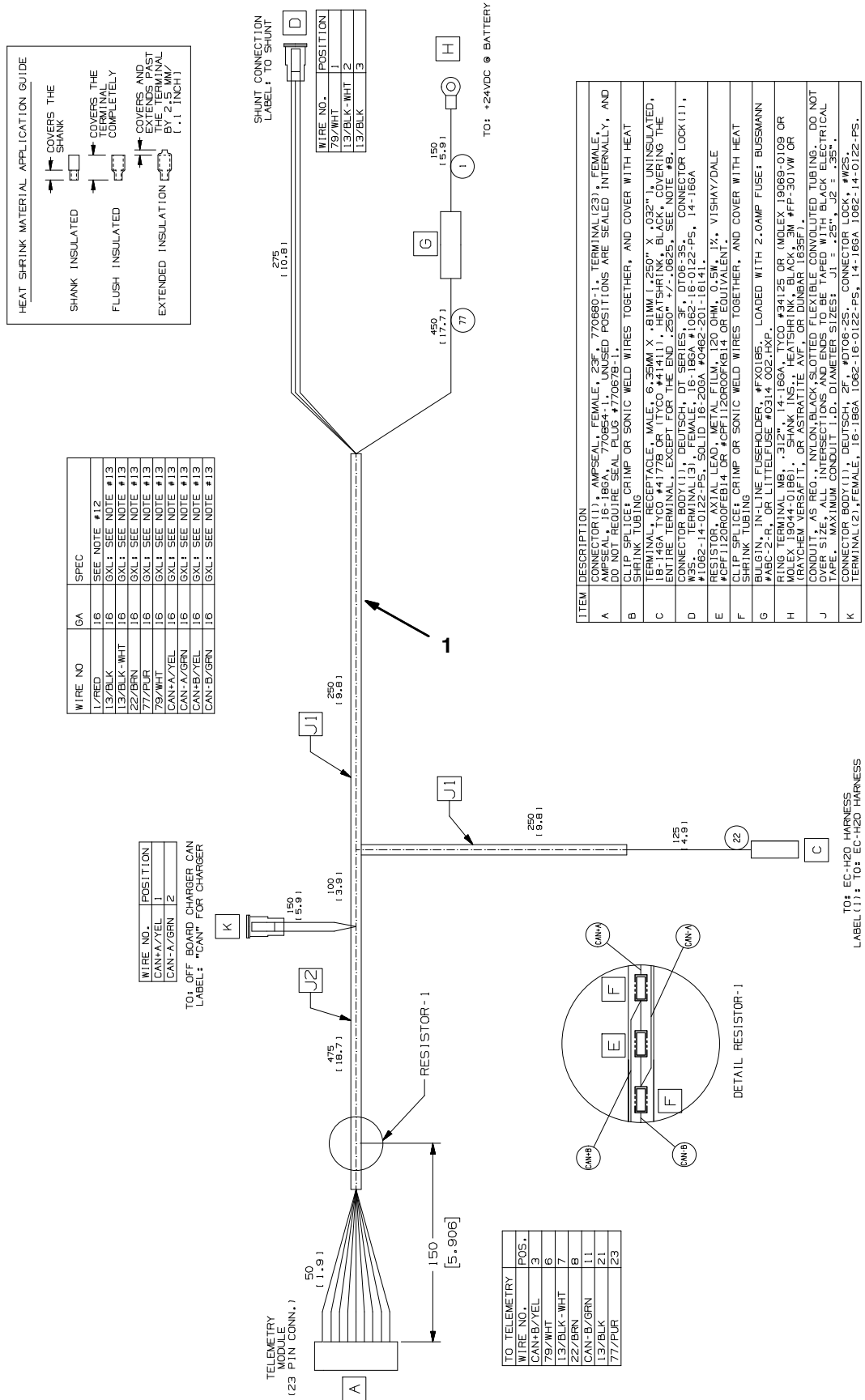

STANDARD PARTS

Fig. 45 – Wire Harnesses Group, Iris Telemetry

	Ref.	Part No.	Description	Qty.
▽	1	1074466	① Harness, Ele, Telem [T7]	1
▲		9009990	① Vr, Fuse, 002a, 250vdc, Cartridge	1

① Serial number (11000–)

Fig. 46 - Cable Assembly, Iris Telemetry

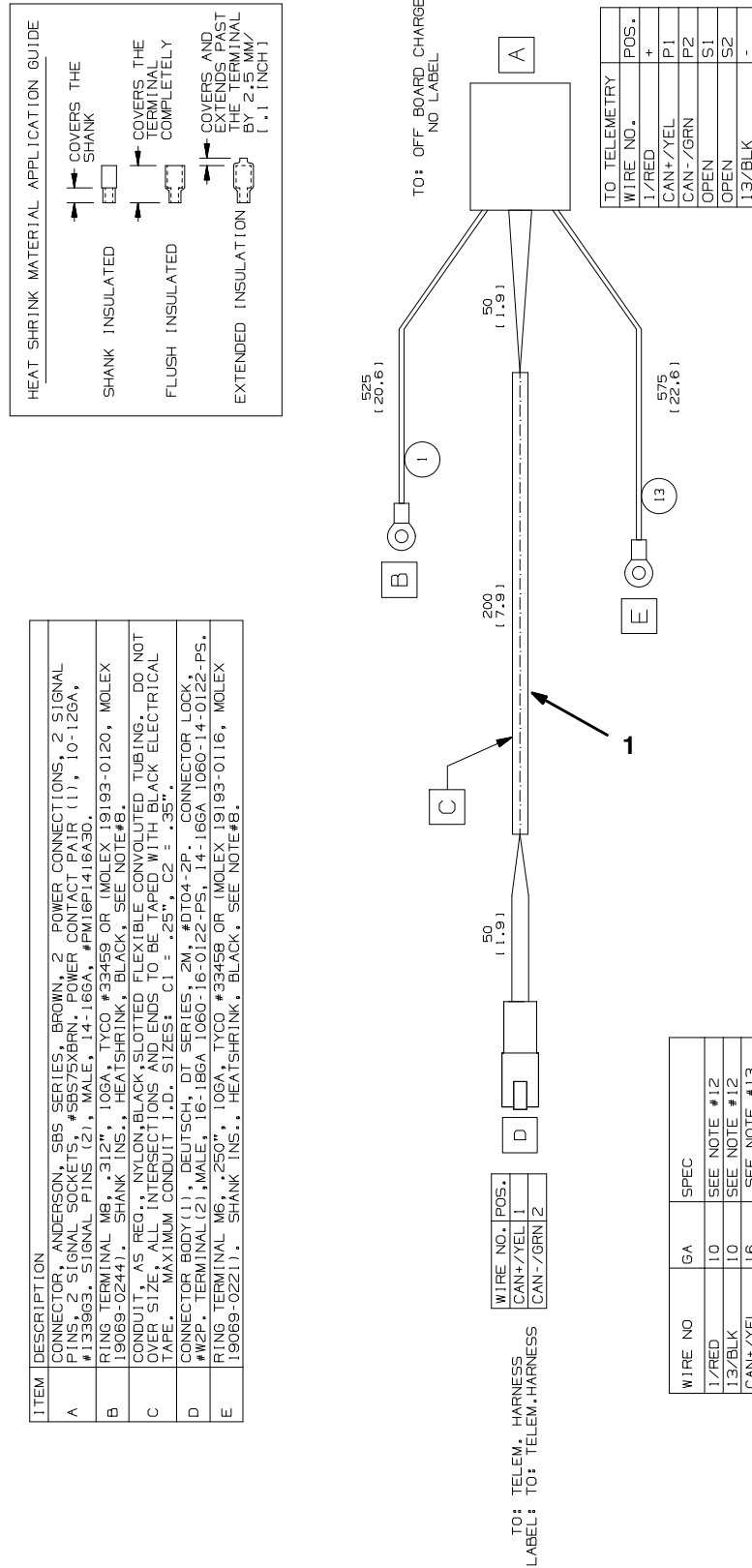

Ref.	Part No.	Description	Qty.
1	1075477	1 Cable, Assy, Telem [T7, Sbs-brn]	1

1 Serial number (12695-)

Fig. 47 – Label Group

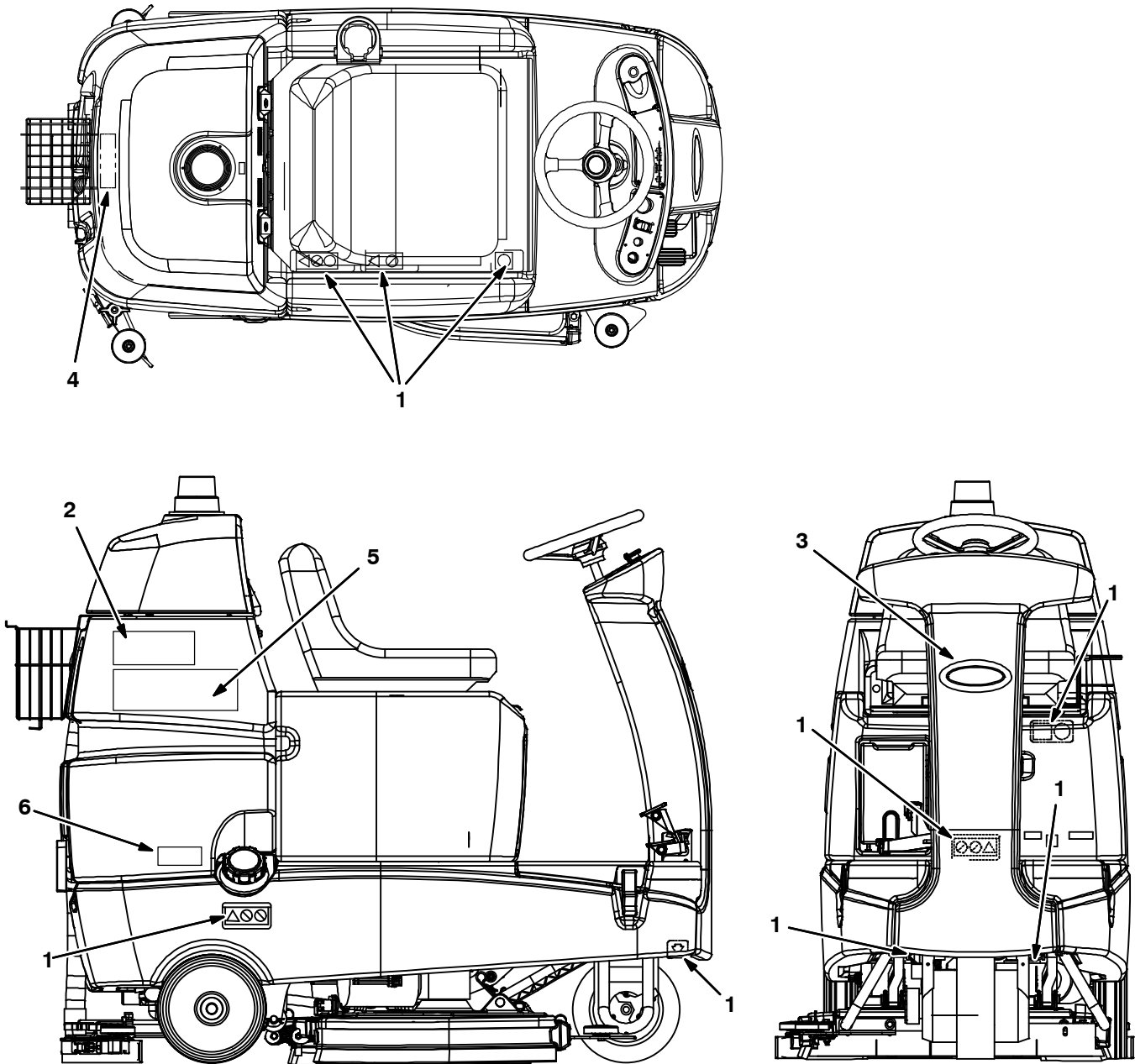

Ref.	Part No.	Description	Qty.
1	1019559	Label Set, Info/Hzrd, Ce	1
2	1074272	Label, Model [T7+]	2
2	1056545	Label, Model, Side [T7 Fast]	2
3	1213114	Label, Logo, 05.5l, Blk/Sil [Tennant]	1
4	1047747	Label, Logo, 06.9l, White, Hg, [Tennant]	1
5	1216520	② Label, Logo [Ech2o Nano]	2
5	1062813	① Label, Logo, 12.3l 4color [Ec-H2o]	2
5	1062814	Label, Logo, 06.1l White / TI [Fast]	2
6	1050003	Label [User, Attention, Ec-H2o]	1
6	391451	Label [Attention Fast Users, 5400s]	1

① Serial number (10000–10999)

② Serial number (11000–)

SECTION 3

Contents	Page
Fig. 1 – FaST Group, Disk Scrub Head	3-2
Fig. 2 – FaST Group, Cylindrical Scrub Head . . .	3-4
Fig. 3 – ec-H2O NanoClean Group, Disc Scrub Head (S/N 11000–)	3-6
Fig. 4 – ec-H2O Group, Disc Scrub Head (S/N 10000–10999)	3-8
Fig. 5 – ec-H2O NanoClean Group, Cylindrical Scrub Head (S/N 11000–)	3-10
Fig. 6 – ec-H2O Group, Cylindrical Scrub Head (S/N 10000–10999)	3-12
Fig. 7 – Iris Telemetry Group (S/N 11000 –)	3-14
Fig. 8 – Kit, Iris Telemetry Battery Manager	3-16
Fig. 9 – Battery Charger, On–Board (S/N 11773–)	3-18
Fig. 10 – Battery Charger, On–Board (S/N 10000 – 11772)	3-20
Fig. 11 – Battery and Charger Group 360Ah/5H	3-22
Fig. 12 – Battery and Charger Group 255Ah/5H	3-23
Fig. 13 – Battery and Charger Group 240Ah/5H	3-24
Fig. 14 – Battery and Charger Group 180Ah/5H	3-25
Fig. 15 – Battery and Charger Group 24V/275Ah/5H	3-26
Fig. 16 – Battery and Charger Group 24V/240Ah/5H	3-27
Fig. 17 – Battery and Charger Group 24V/300Ah/5H	3-28
Fig. 18 – Flashing Light Group	3-29
Fig. 19 – Documentation Group (Online Only) . .	3-30

Fig. 1 - FaST Group, Disk Scrub Head

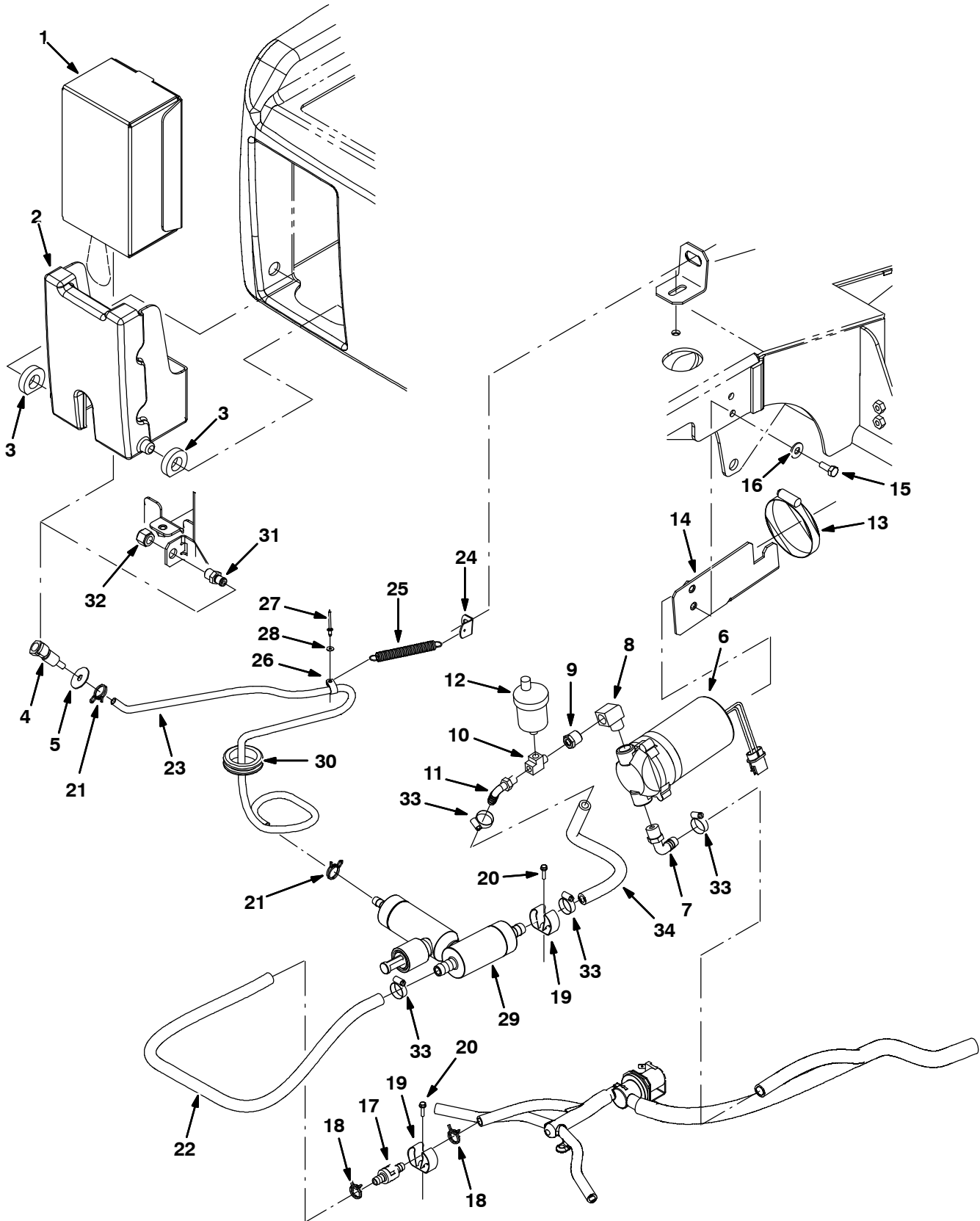

Fig. 1 – FaST Group, Disk Scrub Head

Ref.	Part No.	Description	Qty.	
1	NLA	Cleaner, Floor, Neutral [365 Fast 2x2]	1	
1	NLA	Detergent, Hd [Fast, 965, 2x2 L]	1	
2	1014420	Box, Holder Ce [Fast]	1	
3	1016553	Seal, Rbr	2	
4	1002898	Fitting, Plstc, Str, Bm04, Cplg, Fem	1	
5	30013	Washer, Flat, 0.31 Fender	1	
▽	6	1014282	Pump, Soltn, Ele, 24vdc	1
▲		9001240	Pump Kit, Head, Soltn	1
7	64778	Fitting, Plstc, E90, Bm08/Pm06	1	
8	24584	Fitting, Brs, E90, Pm06/Pf06 Special	1	
9	24698	Fitting, Brs, Str, Pf02/Pm06	1	
10	26426	Fitting, Brs, Tee, Pf02/Pm02/Pm02	1	
11	1005564	Fitting, Plstc, E90, Bm06/Pm02, Nyl	1	
12	1017386	Valve, Air Vent, Float Type	1	
13	43555	Clamp, Hose, Wormdrive, 1.62–3.50d, .56w	1	
14	1014617	Bracket, Pump, Soltn	1	
15	09740	Screw, Hex, M8 X 1.25 X 20, Ss	2	
16	01685	Washer, Flat, 0.31 Ss	2	
17	1015455	Valve, Check, Bm06/Bm06, 5psi	1	
18	607775	Clamp, Hose, Wire, .63 – .66, Blk	2	
19	573073	Clip, Grip, Hose, 1.00–1.38, Zn	1	
20	1016520	Screw, Hex, M4 X 0.7 16 Fmg, Ss	2	
21	613735	Clamp, Hose, Wir, .40 – .42, Yel	2	
22	1006400	Hose, Afmkt, Pvc, Brd 0.38id 3ft	1	
23	1006415	Hose, Afmkt, Pvc, Clr 0.25id 3ft	1	
24	18188	Bracket, Spring	1	
25	1018504	Spring, Extn, 0.50od X 0.04wir, 4.0l	1	
26	26395–2	Clamp, Cable, Stl, 0.38d X 0.38w, 1h	1	
27	56799	Rivet, Blind, .125d X 0.38 X .25d, Alm	1	
28	02892	Washer, Flat, 0.12b 0.38d .03, Stl, Pl	1	
29	9008885	Fast Kit, Injector, Ci[T7/Ssr/T16 Fast3] (See Breakdown)	1	
30	10632–13	Grommet, Rbr, 1.50id, F/ 1.8h, .19matl	1	
31	1002899	Fitting, Plstc, Str, Pm04, Cplg, Mal	1	
32	1005435	Fitting, Plstc, Pipe, Cap, Pf04	1	
33	54333	Clamp, Hose, Wormdrive, 0.31–0.88d, .31w	4	
34	1014974	Hose, Afmkt, Pvc, Brd 0.38id 2ft	1	

NLA = No Longer Available

Fig. 2 – FaST Group, Cylindrical Scrub Head

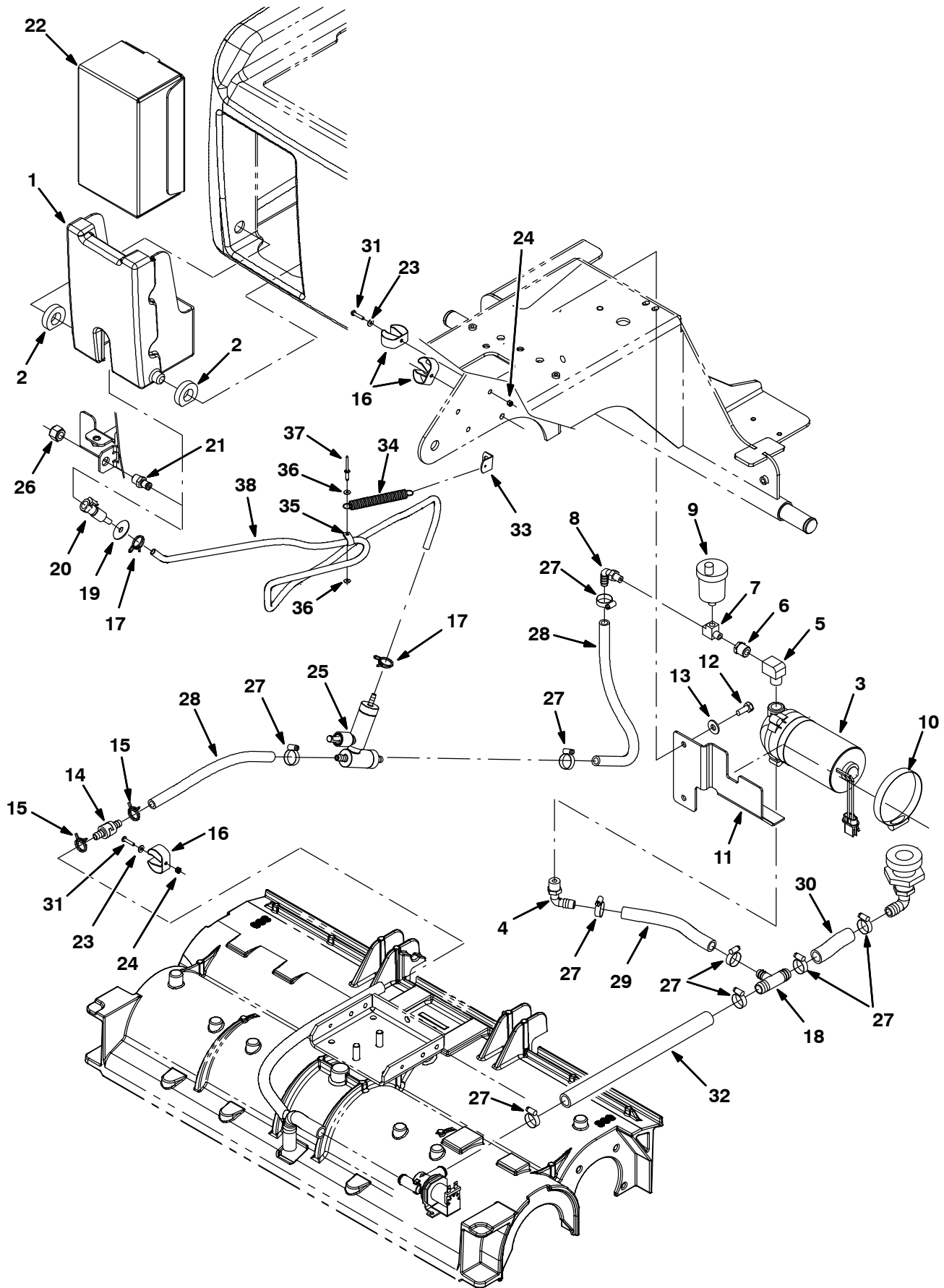

Fig. 2 – FaST Group, Cylindrical Scrub Head

Ref.	Part No.	Description	Qty.	
1	1014420	Box, Holder Ce [Fast]	1	
2	1016553	Seal, Rbr	2	
▽	3	1014282	Pump, Soltn, Ele, 24vdc	1
▲	9001240	Pump Kit, Head, Soltn	1	
4	64778	Fitting, Plstc, E90, Bm08/Pm06	1	
5	24584	Fitting, Brs, E90, Pm06/Pf06 Special	1	
6	24698	Fitting, Brs, Str, Pf02/Pm06	1	
7	26426	Fitting, Brs, Tee, Pf02/Pm02/Pm02	1	
8	1005564	Fitting, Plstc, E90, Bm06/Pm02, Nyl	1	
9	1017386	Valve, Air Vent, Float Type	1	
10	43555	Clamp, Hose, Wormdrive, 1.62–3.50d, .56w	1	
11	1029095	Bracket, Pump, Solution	1	
12	09740	Screw, Hex, M8 X 1.25 X 20, Ss	2	
13	01685	Washer, Flat, 0.31, Ss	2	
14	1015455	Valve, Check, Bm06/Bm06, 5psi	1	
15	607775	Clamp, Hose, Wir, .63 – .66, Blk	2	
16	573073	Clip, Grip, Hose, 1.00–1.38, Zn	3	
17	613735	Clamp, Hose, Wir, .40 – .42, Yel	2	
18	1015486	Fitting, Plstc, Tee, Bm08/Bm10/Bm10, Br	1	
19	30013	Washer, Flat, 0.31, Fendr	1	
20	1002898	Fitting, Plstc, Str, Bm04, Cplg, Fem	1	
21	1002899	Fitting, Plstc, Str, Pm04, Cplg, Mal	1	
22	NLA	Cleaner, Floor, Neutral [365 Fast 2x2]	1	
22	NLA	Detergent, Hd [Fast, 965, 2x2 L]	1	
23	140011	Washer, Flat, 0.21b 0.45d .03, Ss	3	
24	33932	Nut, Hex, Lock, M4 X 0.70, NI, Ss	3	
25	9008885	Fast Kit, Injector, Ci[T7/Ssr/T16 Fast3] (See Breakdown)	1	
26	1005435	Fitting, Plstc, Pipe, Cap, Pf04	1	
27	54333	Clamp, Hose, Wormdrive, 0.31–0.88d, .31w	9	
28	1014971	Hose, Afmkt, Pvc, Brd, 0.38id, 01ft, Clr	3	
29	1011403	Hose, Afmkt, Pvc, Brd, 0.50id, 01ft, Clr	1	
30	1015033	Hose, Afmkt, Pvc, Brd 0.62id 01ft	1	
31	607006	Screw, Trs, M4 X 0.70 X 12, Phl, PI	3	
32	1015026	Hose, Afmkt, Pvc, Brd 0.62id 03ft	1	
33	18188	Bracket, Spring	1	
34	1018504	Spring, Extn, 0.50od X 0.04wir, 4.0l	1	
35	26395–2	Clamp, Cable, Stl, 0.38d X 0.38w, 1h	1	
36	02892	Washer, Flat, 0.12b 0.38d .03, Stl, PI	2	
37	1021677	Rivet, Blind, .154d X 0.55 X .38d, Ss	1	
38	1014985	Hose, Afmkt, Pvc, Clr 0.25id 08ft	1	

NLA = No Longer Available

Fig. 3 – ec-H2O NanoClean Group, Disc Scrub Head (S/N 11000-)

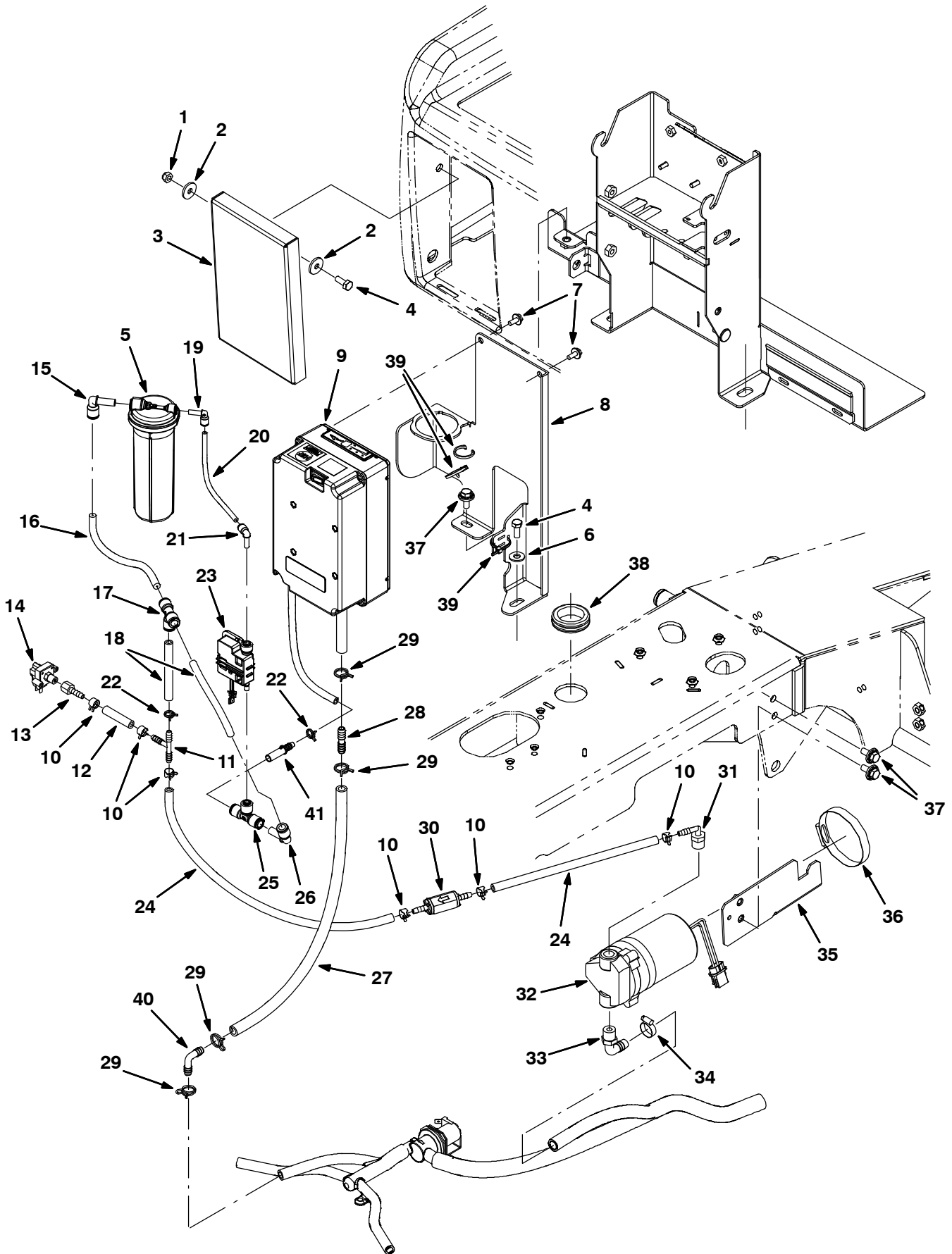

Fig. 3 – ec-H2O NanoClean Group, Disc Scrub Head (S/N 11000–)

Ref.	Part No.	Description	Qty.	
1	08713	Nut, Hex, Lock, M8 X 1.25, NI, Ss	2	
2	1017218	Washer, Flat, 0.32b 1.00d .12, Ss	4	
3	1051138	Bracket, Cover, Fast Opng [T7 Ec-H2o]	1	
4	09740	Screw, Hex, M8 X 1.25 X 20, Ss	3	
5	9013646	② Cartridge, Ec-H2o Nanoclean Wcm, 270ml	1	
6	01685	Washer, Flat, 0.38b 0.88d .08, Ss	1	
7	1034731	Screw, Hex, M6 X 1.00 X 16, Ss, Sems	2	
8	1216192	② Bracket, Module, Ec-H20 [T7]	1	
9	9021553	⑤ Module Kit, Replmt [Ec-H2o, B 02] (See Breakdowns)	1	
9	9020643	④ Module Kit, Replmt [Ec-H2o, B 02](See Breakdowns) (Replaced By 9021553)	1	
9	9011810	③ Module Kit, Replmt [Ec-H2o, B 02] (See Breakdowns) (Replaced By 9021553)	1	
10	603654	② Clamp, Hose, Ear, .44d [Ctb]	6	
11	150713	Fitting, Plstc, Tee, Bm04/Bm04/Bm04	1	
12	575523000	Hose, Pvc, Brd, 0.25id 0.44od 043.5l,Clr	1	
13	150520	Fitting, Brs, Str, Bm04/Pf02	1	
14	1044415	Switch, Press, 20psi, Pm02	1	
15	1215186	② Fitting, Plstc, E90, Qf06/Qm06	1	
16	9014146	② Hose, Afmkt, Pvc, 0.06id .38od, 05ft	1	
17	1212573	② Fitting, Plstc, Tee, Qf06/Qf06/Qf06	1	
18	1014987	② Hose, Afmkt, Pvc, Clr, 0.25id, 01ft	1	
19	1214339	② Fitting, Plstc, E90, Qfo4/Qm04	1	
20	9014147	② Hose, Afmkt, Pvc, 0.06id .25od, 05ft	1	
21	1214339	② Fitting, Plstc, E90, Qfo4/Qm04	1	
22	613735	Clamp, Hose, Wir, .40 – .42, Yel	2	
23	1216973	② Pump Assy, Dispenser	1	
24	9014210	② Hose, Afmkt, Pvc, Brd .25id .44od, 05ft	1	
25	1212855	② Fitting, Plstc, Tee, Qf04/Qf06/Qf06	1	
26	1215186	② Fitting, Plstc, E90, Qf06/Qm06	1	
27	1006400	② Hose, Afmkt, Pvc, Brd, 0.38id, 03ft, Clr	1	
28	20950	② Fitting, Plstc, Str, Bm06/Bm06	1	
29	607775	② Clamp, Hose, Wir, .63 – .66, Blk	4	
30	1216879	② Valve, Check, 0005psi Bm04/Bm04	1	
31	150417	② Fitting, Plstc, E90, Bm04/Pm06	1	
▽	32	1042592	Pump, Soltn, Ele, 24vdc, 35psi [Ce]	1
▲	1020021	Connector, Cap, Superseal 1.5, Replmt	1	
33	64778	Fitting, Plstc, E90, Bm08/Pm06	1	
34	54333	Clamp, Hose, Wormdrive, 0.31–0.88d, .31w	1	
35	1014617	Bracket, Pump, Soltn	1	
36	43555	Clamp, Hose, Wormdrive, 2.50–3.50d, .50w	1	
37	1020341	Screw, Hex, M8 X 1.25 X 20, Ss, Sems	3	
38	10632–13	Grommet, Rbr, 1.50id, F/1.8h, .19 Matl	1	
39	130773	② Tie, Cable, Nyl, 11.0l, .14w, 3.0 Max. D	3	
40	20951	Fitting, Plstc, E90, Bm06/Bm06	1	
41	1212857	Fitting, Plstc, Str, Qm06/Bm04	1	

② Serial number (11000–)

③ Serial number (11000–16185)

④ Serial number (16186–AUG2022)

⑤ Serial number (SEP2022–)

Fig. 4 – ec-H2O Group, Disc Scrub Head (S/N 10000–10999)

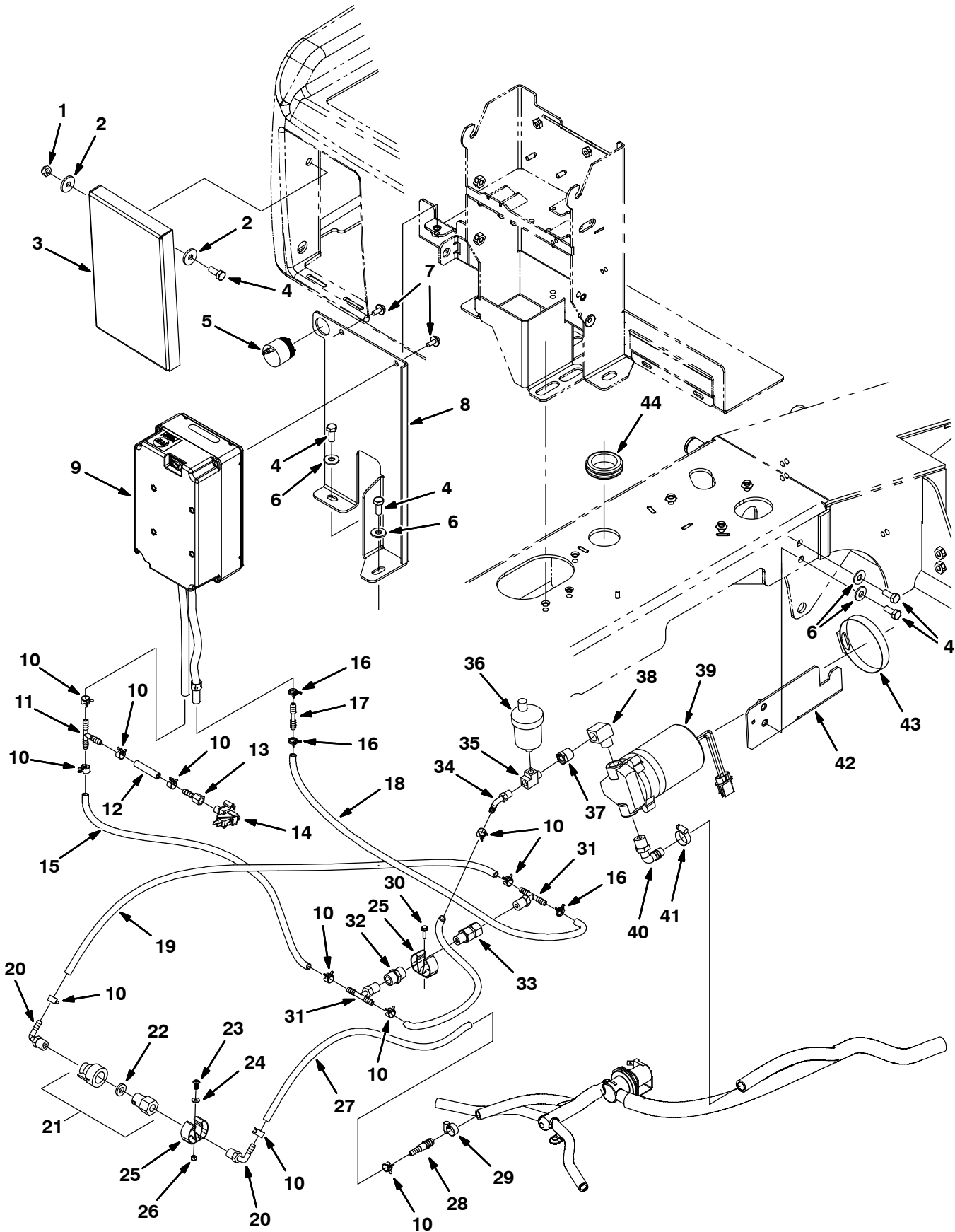

Fig. 4 – ec-H2O Group, Disc Scrub Head (S/N 10000–10999)

Ref.	Part No.	Description	Qty.	
1	08713	Nut, Hex, Lock, M8 X 1.25, NI, Ss	2	
2	1017218	Washer, Flat, 0.32b 1.00d .12, Ss	4	
3	1051138	Bracket, Cover, Fast Opng [T7 Ec-H2o]	1	
4	09740	① Screw, Hex, M8 X 1.25 X 20, Ss	6	
5	1052726	① Alarm, 9–48vdc, 95 Db(A) [Ec-H20]	1	
6	01685	① Washer, Flat, 0.38b 0.88d .08, Ss	4	
7	1034731	Screw, Hex, M6 X 1.00 X 16, Ss, Sems	2	
8	1050052	① Bracket, Module, Ec-H2o [T7]	1	
9	9007970	① Module Kit, Replmt [Ec-H2o] (See Breakdown)	1	
10	603654	① Clamp, Hose, Ear, .44d [Ctb]	11	
11	150713	Fitting, Plstc, Tee, Bm04/Bm04/Bm04	1	
12	575523000	Hose, Pvc, Brd, 0.25id 0.44od 043.5l,Clr	1	
13	150520	Fitting, Brs, Str, Bm04/Pf02	1	
14	1044415	Switch, Press, 20psi, Pm02	1	
15	575523000	Hose, Pvc, Brd, 0.25id 0.44od 043.5l,Clr	1	
16	613735	① Clamp, Hose, Wir, .40 – .42, Yel	3	
17	1052705	① Fitting, Plstc, Str, Bm04/Bm04	1	
18	1006415	① Hose, Afmkt, Pvc, Clr, 0.25id, 03ft	1	
19	575523000	① Hose, Pvc, Brd, 0.25id 0.44od 043.5l,Clr	1	
20	1011170	① Fitting, Plstc, E90, Bm04/Pm04, Nyl	2	
▽	21	1043866	① Fitting Assy, Qdc, Pf04	1
▲	22	1047655	① Washer, Flat, 0.40b 0.75d .12 [Viton]	1
	23	607006	① Screw, Trs, M4 X 0.70 X 12, Phl, Pl	1
	24	140011	① Washer, Flat, 0.21b 0.45d .03, Ss	1
	25	1014295	① Clip, Grip, Hose, 0.75–1.12, Stl,Blk Vyl	3
	26	33932	① Nut, Hex, Lock, M4 X 0.70, NI, Ss	1
	27	575523000	① Hose, Pvc, Brd, 0.25id 0.44od 043.5l,Clr	1
	28	1039557	① Fitting, Plstc, Str, Bm04/Bm06	1
	29	43844	① Clamp, Hose, Wormdrive, 0.25–0.62d, .31w	1
	30	1016520	① Screw, Hex, M4 X 0.70 X 16, Fmg, Ss	2
	31	607306	① Fitting, Plstc, Tee, Bm04/Bm04/Pm04, Br	2
	32	150302	① Fitting, Brs, Str, Pf04/Pf04	1
	33	1044790	① Valve, Check, 0025psi Pm04/Pf04	1
	34	1037595	① Fitting, Plstc, E90, Bm04/Pm02, Nyl	1
	35	26426	① Fitting, Brs, Tee, Pf02/Pf02/Pm02, Run	1
	36	1017386	① Valve, Vent, Air, Float Type	1
	37	24698	① Fitting, Brs, Str, Pf02/Pm06	1
	38	24584	① Fitting, Brs, E90, Pf06/Pm06, Spcl	1
▽	39	1042592	Pump, Soltn, Ele, 24vdc, 35psi [Ce]	1
▲		1020021	Connector, Cap, Superseal 1.5, Replmt	1
	40	64778	Fitting, Plstc, E90, Bm08/Pm06	1
	41	54333	Clamp, Hose, Wormdrive, 0.31–0.88d, .31w	1
	42	1014617	Bracket, Pump, Soltn	1
	43	43555	Clamp, Hose, Wormdrive, 2.50–3.50d, .50w	1
	44	10632–13	Grommet, Rbr, 1.50id, F/1.8h, .19 Matl	1

① Serial number (10000–10999)

Fig. 5 - *ec-H2O* NanoClean Group, Cylindrical Scrub Head (S/N 11000-)

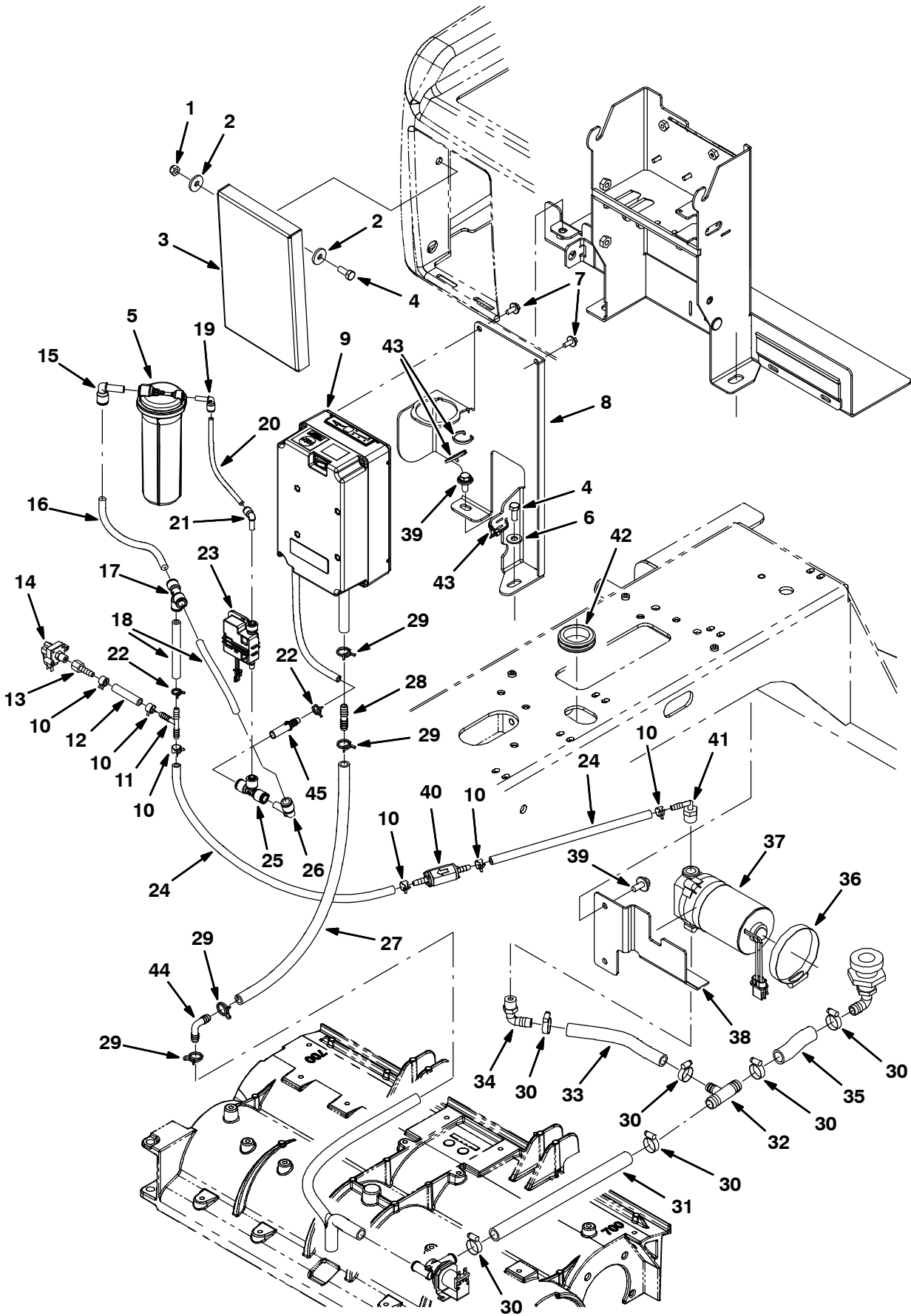

Fig. 5 – ec-H2O NanoClean Group, Cylindrical Scrub Head (S/N 11000–)

Ref.	Part No.	Description	Qty.	
1	08713	Nut, Hex, Lock, M8 X 1.25, NI, Ss	2	
2	1017218	Washer, Flat, 0.32b 1.00d .12, Ss	4	
3	1051138	Bracket, Cover, Fast Opng [T7 Ec-H2o]	1	
4	09740	[2] Screw, Hex, M8 X 1.25 X 20, Ss	3	
5	9013646	[2] Cartridge, Ec-H2o Nanoclean Wcm, 270ml	1	
6	01685	[2] Washer, Flat, 0.38b 0.88d .08, Ss	1	
7	1034731	Screw, Hex, M6 X 1.00 X 16, Ss, Sems	2	
8	1216192	[2] Bracket, Module, Ec-H20 [T7]	1	
9	9021553	[5] Module Kit, Replmt [Ec-H2o, B 02] (See Breakdowns)	1	
9	9020643	[4] Module Kit, Replmt [Ec-H2o, B 02](See Breakdowns) (Replaced By 9021553)	1	
9	9011810	[3] Module Kit, Replmt [Ec-H2o, B 02] (See Breakdowns) (Replaced By 9021553)	1	
10	603654	[2] Clamp, Hose, Ear, .44d [Ctb]	5	
11	150713	Fitting, Plstc, Tee, Bm04/Bm04/Bm04	1	
12	575523000	Hose, Pvc, Brd, 0.25id 0.44od 043.5l,Clr	1	
13	150520	Fitting, Brs, Str, Bm04/Pf02	1	
14	1044415	Switch, Press, 20psi, Pm02	1	
15	1215186	[2] Fitting, Plstc, E90, Qf06/Qm06	1	
16	9014146	[2] Hose, Afmkt, Pvc, 0.06id .38od, 05ft	1	
17	1212573	[2] Fitting, Plstc, Tee, Qf06/Qf06/Qf06	1	
18	1014987	[2] Hose, Afmkt, Pvc, Clr, 0.25id, 01ft	1	
19	1214339	[2] Fitting, Plstc, E90, Qfo4/Qm04	1	
20	9014147	[2] Hose, Afmkt, Pvc, 0.06id .25od, 05ft	1	
21	1214339	[2] Fitting, Plstc, E90, Qfo4/Qm04	1	
22	613735	Clamp, Hose, Wir, .40 – .42, Yel	2	
23	1216973	[2] Pump Assy, Dispenser	1	
24	9014210	[2] Hose , Afmkt, Pvc, Brd .25id .44od, 05ft	1	
25	1212855	[2] Fitting, Plstc, Tee, Qf04/Qf06/Qf06	1	
26	1215186	[2] Fitting, Plstc, E90, Qf06/Qm06	1	
27	1006400	[2] Hose, Afmkt, Pvc, Brd, 0.38id, 03ft, Clr	1	
28	20950	[2] Fitting, Plstc, Str, Bm06/Bm06	1	
29	607775	[2] Clamp, Hose, Wir, .63 – .66, Blk	4	
30	54333	Clamp, Hose, Wormdrive, 0.31–0.88d, .31w	6	
31	1015026	Hose, Afmkt, Pvc, Brd, 0.62id, 03ft, Clr	1	
32	1015486	Fitting, Plstc, Tee, Bm08/Bm10/Bm10, Br	1	
33	1031304	Hose, Pump (376716)	1	
34	64778	Fitting, Plstc, E90, Bm08/Pm06	1	
35	1031738	Hose, Pvc, Brd, 0.62id 0.88od [C460117]	1	
36	43555	Clamp, Hose, Wormdrive, 2.50–3.50d, .50w	1	
▽	37	1042592	Pump, Soltn, Ele, 24vdc, 35psi [Ce]	1
▲		1020021	Connector, Cap, Superseal 1.5, Replmt	1
38	1029095	Bracket, Pump, Soltn	1	
39	1020341	Screw, Hex, M8 X 1.25 X 20, Ss, Sems	3	
40	1216879	[2] Valve, Check, 0005psi Bm04/Bm04	1	
41	150417	[2] Fitting, Plstc, E90, Bm04/Pm06	1	
42	10632–13	Grommet, Rbr, 1.50id, F/1.8h, .19 Matl	1	
43	130773	[2] Tie, Cable, Nyl, 11.0l, .14w, 3.0 Max. D	3	
44	20951	[2] Fitting, Plstc, E90, Bm06/Bm06	1	
45	1212857	Fitting, Plstc, Str, Qm06/Bm04	1	

[2] Serial number (11000–)

[3] Serial number (11000– 16185)

[4] Serial number (16186–AUG2022)

[5] Serial number (SEP2022–)

Fig. 6 – ec-H2O Group, Cylindrical Scrub Head (S/N 10000–10999)

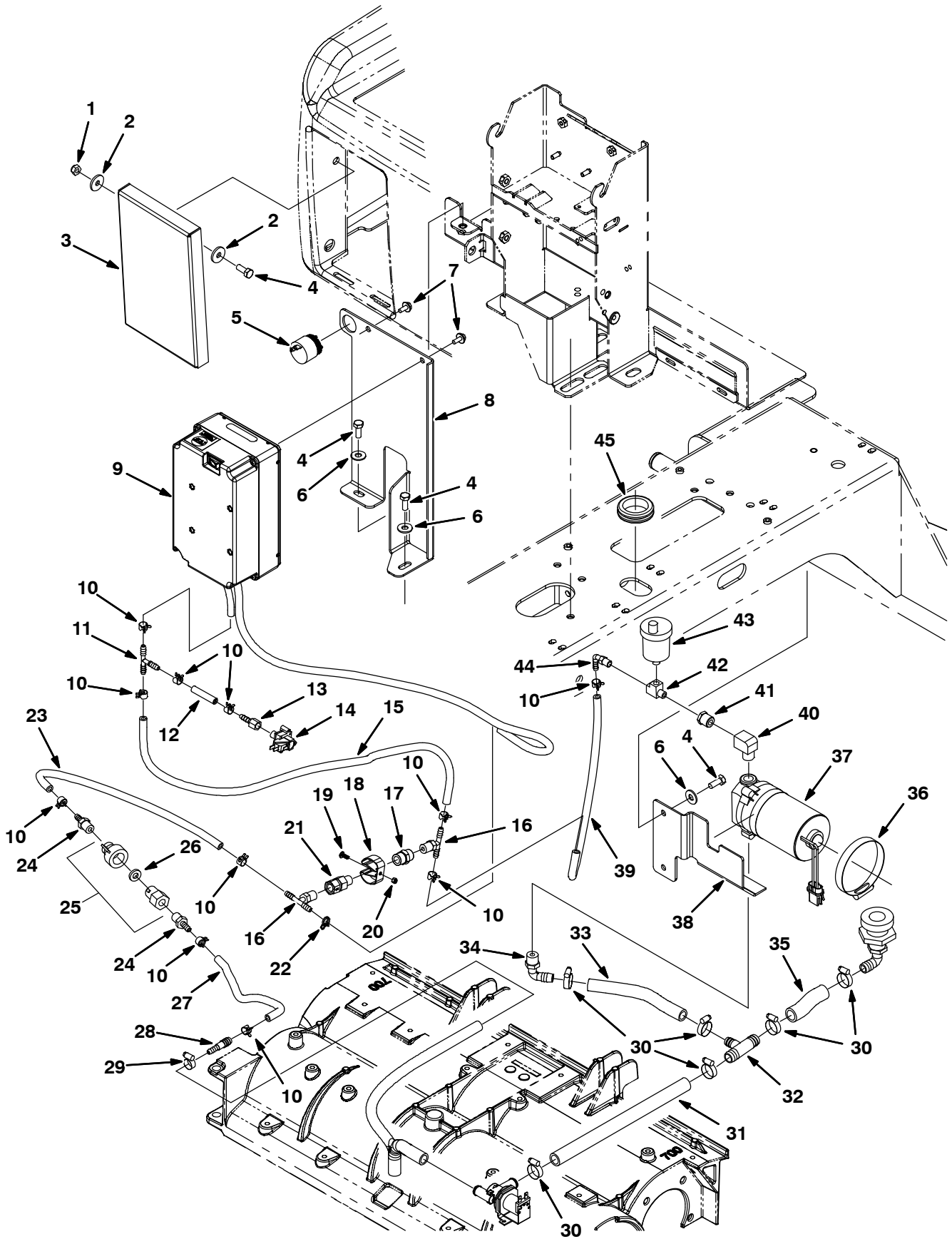

Fig. 6 – ec-H2O Group, Cylindrical Scrub Head (S/N 10000–10999)

Ref.	Part No.	Description	Qty.
1	08713	Nut, Hex, Lock, M8 X 1.25, NI, Ss	2
2	1017218	Washer, Flat, 0.32b 1.00d .12, Ss	4
3	1051138	Bracket, Cover, Fast Opng [T7 Ec-H2o]	1
4	09740	① Screw, Hex, M8 X 1.25 X 20, Ss	6
5	1052726	① Alarm, 9–48vdc, 95 Db(A) [Ec-H20]	1
6	01685	① Washer, Flat, 0.38b 0.88d .08, Ss	4
7	1034731	Screw, Hex, M6 X 1.00 X 16, Ss, Sems	2
8	1050052	① Bracket, Module, Ec-H2o [T7]	1
9	9007970	① Module Kit, Replmt [Ec-H2o] (See Breakdown)	1
10	603654	① Clamp, Hose, Ear, .44d [Ctb]	11
11	150713	Fitting, Plstc, Tee, Bm04/Bm04/Bm04	1
12	575523000	Hose, Pvc, Brd, 0.25id 0.44od 043.5l,Clr	1
13	150520	Fitting, Brs, Str, Bm04/Pf02	1
14	1044415	Switch, Press, 20psi, Pm02	1
15	575523000	Hose, Pvc, Brd, 0.25id 0.44od 043.5l,Clr	1
16	607306	① Fitting, Plstc, Tee, Bm04/Bm04/Pm04, Br	2
17	150302	① Fitting, Brs, Str, Pf04/Pf04	1
18	1014295	① Clip, Grip, Hose, 0.75–1.12, Stl,Blk Vyl	1
19	607006	① Screw, Trs, M4 X 0.70 X 12, Phl, PI	1
20	33932	① Nut, Hex, Lock, M4 X 0.70, NI, Ss	1
21	1044790	① Valve, Check, 0025psi Pm04/Pf04	1
22	613735	① Clamp, Hose, Wir, .40 – .42, Yel	1
23	575523000	① Hose, Pvc, Brd, 0.25id 0.44od 043.5l,Clr	1
24	50901	① Fitting, Plstc, Str, Bm04/Pm04	1
▽	25	① Fitting Assy, Qdc, Pf04	1
▲	26	① Washer, Flat, 0.40b 0.75d .12 [Viton]	1
	27	① Hose, Pvc, Brd, 0.25id 0.44od 043.5l,Clr	1
	28	① Fitting, Plstc, Str, Bm04/Bm06	1
	29	① Clamp, Hose, Wormdrive, 0.25–0.62d, .31w	1
	30	① Clamp, Hose, Wormdrive, 0.31–0.88d, .31w	6
	31	Hose, Afmkt, Pvc, Brd, 0.62id, 03ft, Clr	1
	32	Fitting, Plstc, Tee, Bm08/Bm10/Bm10, Br	1
	33	Hose, Pump (376716)	1
	34	Fitting, Plstc, E90, Bm08/Pm06	1
	35	Hose, Pvc, Brd, 0.62id 0.88od [C460117]	1
	36	Clamp, Hose, Wormdrive, 2.50–3.50d, .50w	1
▽	37	① Pump, Soltn, Ele, 24vdc, 35psi [Ce]	1
▲		① Connector, Cap, Superseal 1.5, Replmt	1
	38	① Bracket, Pump, Soltn	1
	39	① Hose, Pvc, Brd, 0.25id 0.44od 043.5l,Clr	1
	40	① Fitting, Brs, E90, Pf06/Pm06, Spcl	1
	41	① Fitting, Brs, Str, Pf02/Pm06	1
	42	① Fitting, Brs, Tee, Pf02/Pf02/Pm02, Run	1
	43	① Valve, Vent, Air, Float Type	1
	44	① Fitting, Plstc, E90, Bm04/Pm02, Nyl	1
	45	① Grommet, Rbr, 1.50id, F/1.8h, .19 Matl	1

① Serial number (10000–10999)

Fig. 7 - Iris Telemetry Group (S/N 11000 -)

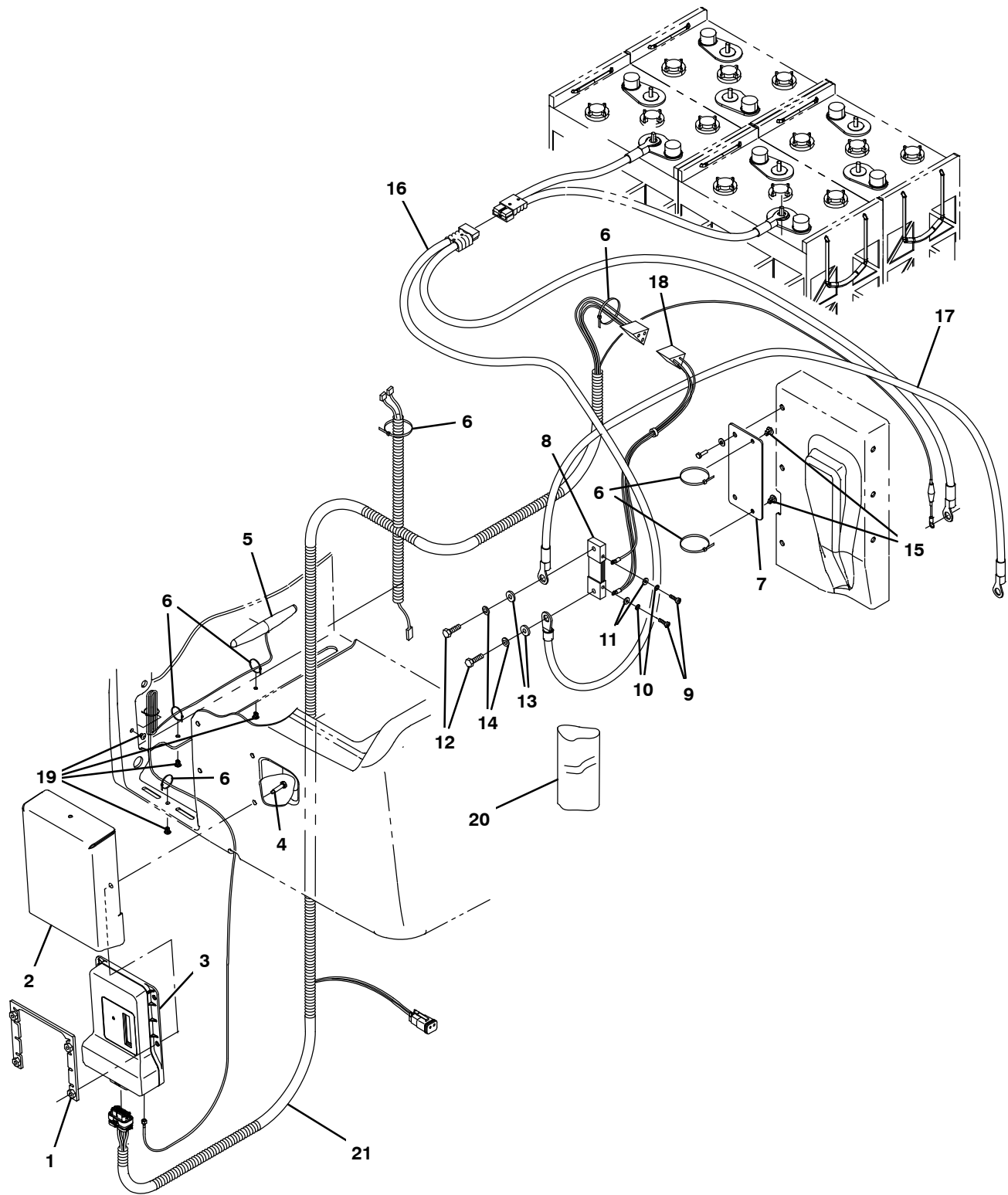

Fig. 7 – Iris Telemetry Group (S/N 11000 –)

Ref.	Part No.	Description	Qty.
1	1218315	① Guard Wldt, Controlbox	1
2	1216835	① Cover, Guard	1
3	9010086	① Control Box Assy Kit, Replmt, Telem[Intl]	1
4	1036892	① Screw, Hex, M6 X 1.00 X 25, 9.8, Sems	4
5	1247522	③ Antenna, Telem [4g, 72"]	1
5	1070659	② Antenna, Telem, 70 In [Gprs] (Replaced By 1247522)	1
6	130773	① Tie, Cable, Nyl, 11.0l, .14w, 3.0 Max. D	15
7	1215943	① Bracket, Shunt	1
8	1217304	① Shunt [Empro, 250amp/50mv, Metric]	1
9	391403	① Screw, Pan, Phl, M4 X 0.70 X 8, Ss	2
10	02938	① Washer, Lock, Int, 08, Ss	2
11	41578	① Washer, Flat, 06, Ss	2
12	15675	① Screw, Hex, M8 X 1.25 X 16, Ss	2
13	01685	① Washer, Flat, 0.38b 0.88d .08, Ss	2
14	43952	① Washer, Lock, Int, 0.31, Ss	2
15	1202868	① Clip, Tie, 0.25D, Plstc	2
▽	16	1074648 ① Cable Assy, 04ga M8 Ring / M8 Ring, 175a	1
▲		605387 ① Connector, Anderson, 050a, Red [W/O Con]	1
	17	1074649 ① Cable, 04ga 13.8l Blk M6 Ring / M8 Ring	1
	18	1074595 ① Harness, Ele [Telem, Shunt]	1
	19	1202868 ① Clip, Tie, 0.25d, Plstc	4
	20	1217818 ① Heatshrink [1.5" Dia., 7.0" Sections]	1
▽	21	1074466 ① Harness, Ele, [Telem, T7]	1
▲		9009990 ① Fuse, 002a, 250vdc, Cartridge	1

① Serial number (11000–)

② Serial number (11000– 15894)

③ Serial number (15895–)

Fig. 8 - Kit, Iris Telemetry Battery Manager

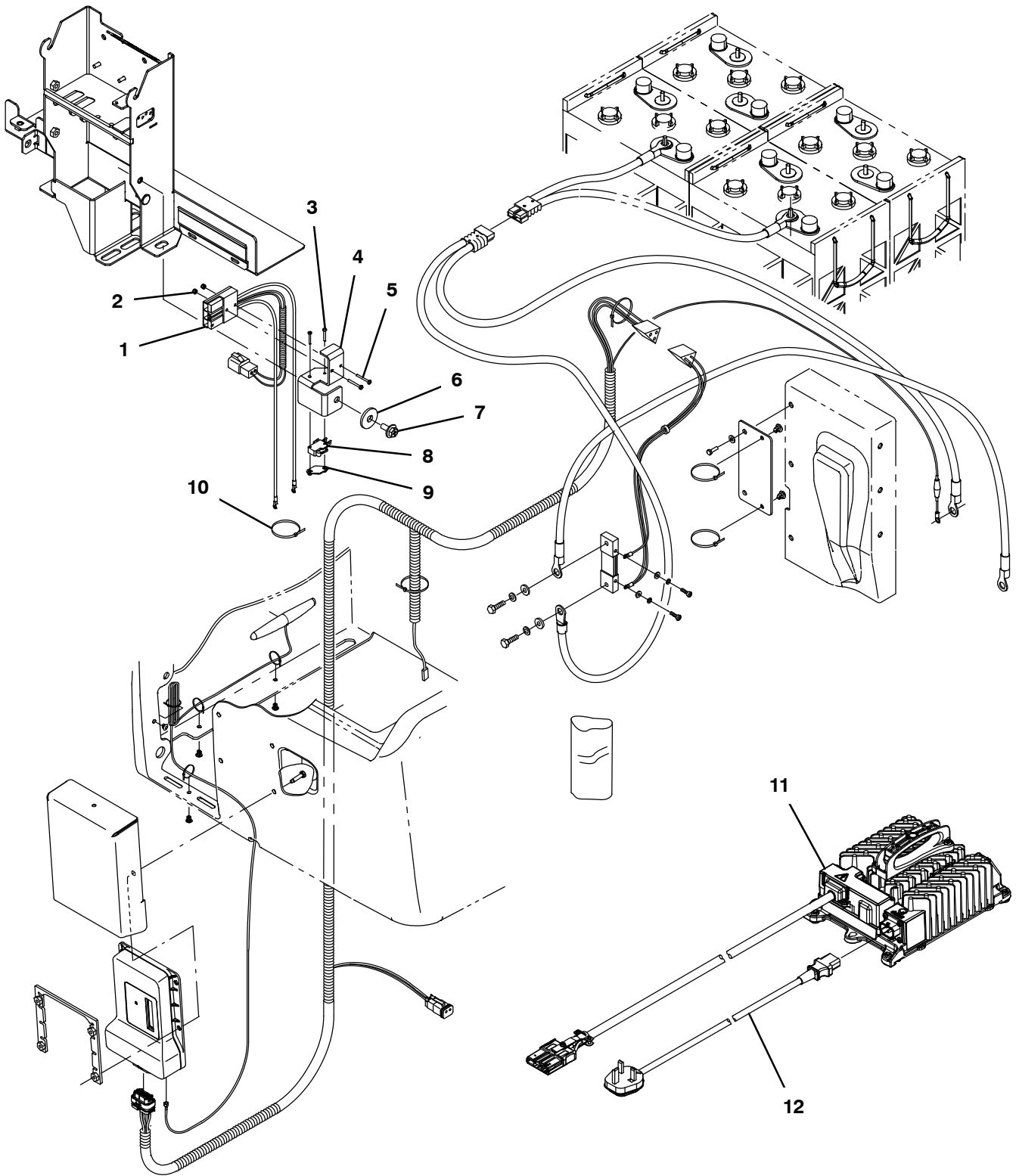

Fig. 8 – Kit, Iris Telemetry Battery Manager

Ref.	Part No.	Description	Qty.
▽	9015933	① Harness Kit, Amii, Ci [T7 Emea] (Kit Needed to Add Battery Manager Functionality to Iris Telemetry Models)	1
▲	1 1075477	② Cable, Assy, Telem [T7, Sbs-Brn]	1
▲	2 579211	② Nut, Hex, Lock, M3 X 0.50, NI, Ss	2
▲	3 06922	② Screw, Pan, Phl, M3 X 0.50 X 20, 4.8	2
▲	4 1230748	② Bracket, Switch, Charger [T7,Tnv]	1
▲	5 06923	② Screw, Pan, Phl, M3 X 0.50 X 25, 4.8	2
▲	6 1017218	② Washer, Flat, 0.32b 1.00d .12, Ss	1
▲	7 1034731	② Screw, Hex, M6 X 1.00 X 16, Sems, Ss	1
▲	8 611005	② Switch, Rlr, 16a, Micro	1
▲	9 995585	② Plate, Thread, Switch	1
▲	10 130773	② Tie, Cable, Nyl, 11.0l, .14w, 3.0 Max. D	5
▲	11 1230312	② Charger, 24vdc, 650w,100-240vac[Off Brd] (Note: Does Not Include Cord) (Models With Iris Battery Manager Functionality Only)	1
	12 1043746	② Cable, Charger Eu, Bc5 Bc7 (Europe) (Not Included In Kit – Use Cord From Current Off-Board Charger)	1
	12 1041716	② Cable, Charger Uk, Bc5 Bc7 (Uk) (Not Included In Kit – Use Cord From Current Off-Board Charger)	1

① Serial number (11000-)

② Serial number (12695-)

Fig. 9 - Battery Charger, On-Board (S/N 11773-)

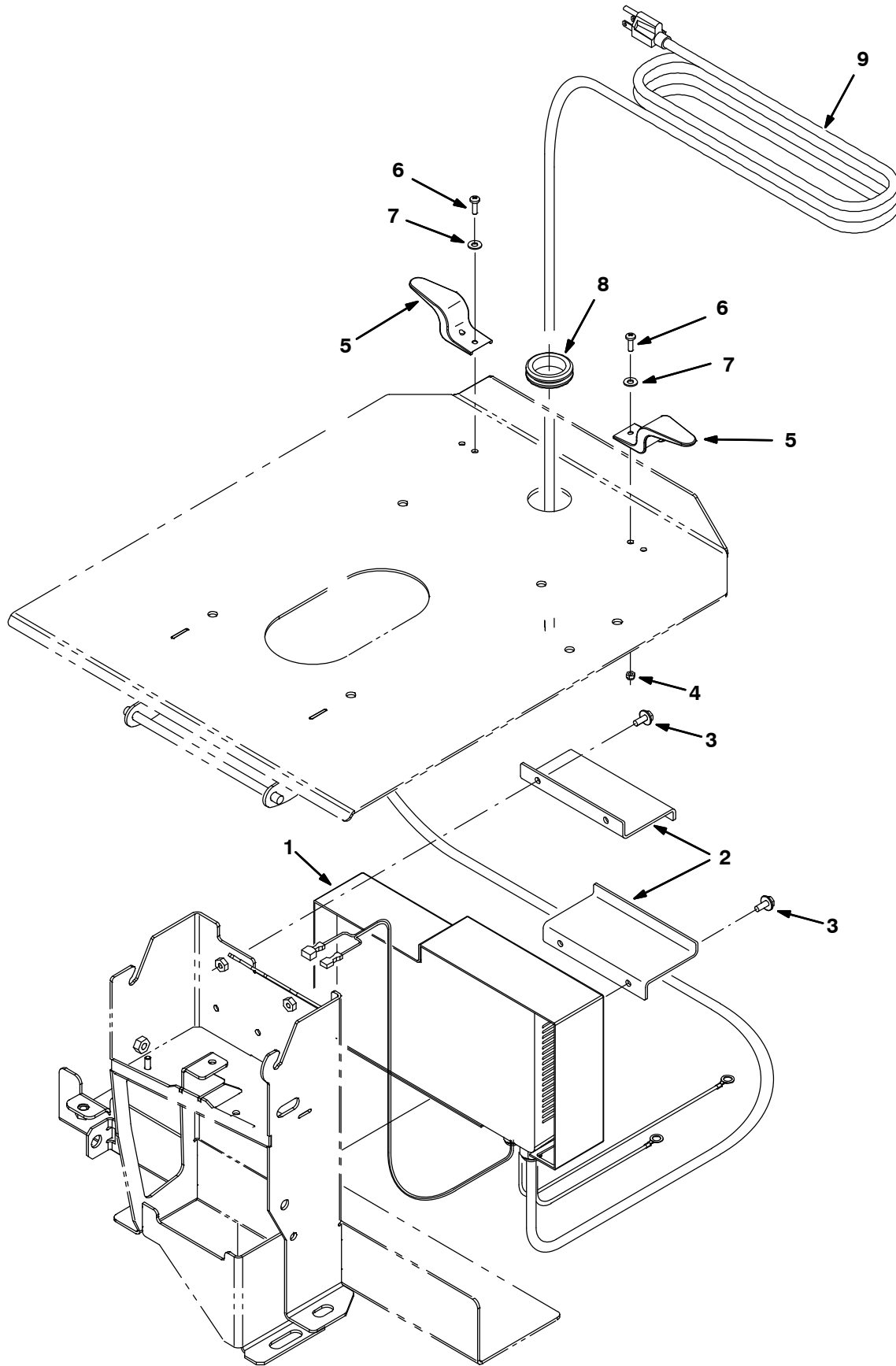

Fig. 9 – Battery Charger, On-Board (S/N 11773–)

Ref.	Part No.	Description	Qty.
1	1250061	☐ Charger, 24vdc 25a 230vac (T7)	1
2	1031180	☐ Bracket, Chrgr	2
3	1034731	☐ Screw, Hex, M6 X 1.00 X 16, Ss, Sems	4
4	06549	☐ Nut, Hex, Lock, M5 X 0.80, NI	4
5	230920.BK	☐ Hook, Cord, Blk [Boss]	2
6	06933	☐ Screw, Pan, M5 X 0.80 X 16, 4.8	4
7	01684	☐ Washer, Flat, 0.27b 0.69d .05, Ss	4
8	10632-13	☐ Grommet, Rbr, 1.50id, F/1.8h, .19 Matl	1
9	1032849	☐ Cord, Power, Blk [4.5meter, Ce]	1
9	1032820	☐ Cord, Power, Blk [4.5meter, Uk]	1

☐ Serial number (11773–)

Fig. 10 – Battery Charger, On-Board (S/N 10000 – 11772)

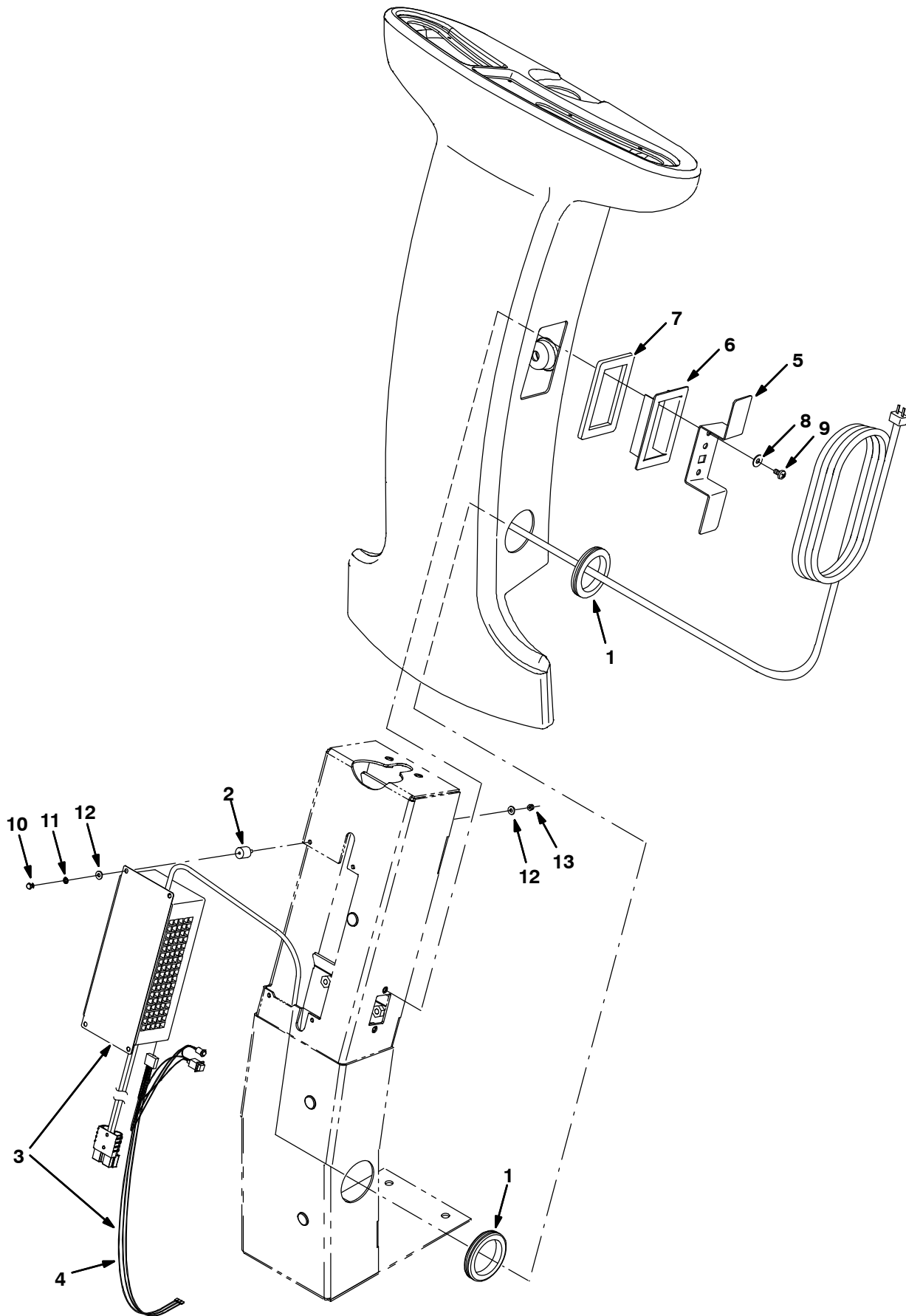

Fig. 10 – Battery Charger, On-Board (S/N 10000 – 11772)

Ref.	Part No.	Description	Qty.
1	10632-19	☐ Grommet, Rbr, 2.13id, F/2.5h, .12 Matl	2
2	1037762	☐ Isolator, Vib, 15mmd, M4 H, M4 Stud	4
▽	3	☐ 1032388* Charger, 24vdc, 20a 230vac 50/60hz	1
▲	4	☐ 1033516* Harness Assy, Light, Chrgr, Tnv [T7]	1
▽	3	☐ 1033793* Charger, 24vdc 20a 230vac [Uk]	1
▲	4	☐ 1033516* Harness Assy, Light, Chrgr, Tnv [T7]	1
	5	☐ 1033415 Bracket, Cord, Chrgr, Tnv	1
	6	☐ 1033417 Bracket, Cord, Chrgr, Tnv [T7]	1
	7	☐ 1033419 Seal, Ure, 0.24, 03.3w 04.5l Adh, Tnv	1
	8	☐ 01684 Washer, Flat, 0.27b 0.69d .05, Ss	2
	9	☐ 74027 Screw, Pan, M6 X 1.0 X 12, Ss, NI	2
	10	☐ 21237 Screw, Hex, M4 X 0.7 X 6, 8.8	4
	11	☐ 32978 Washer, Lock, Int, 08	4
	12	☐ 19065 Washer, Flat, 08	8
	13	☐ 02850 Nut, Hex, Lock, M4 X 0.70, NI	4

☐ Serial number (10000-11772)

* NOTE: OBSOLETE PLEASE CONTACT LOCAL SERVICE REPRESENTATIVE.

Fig. 11 – Battery and Charger Group 360Ah/5H

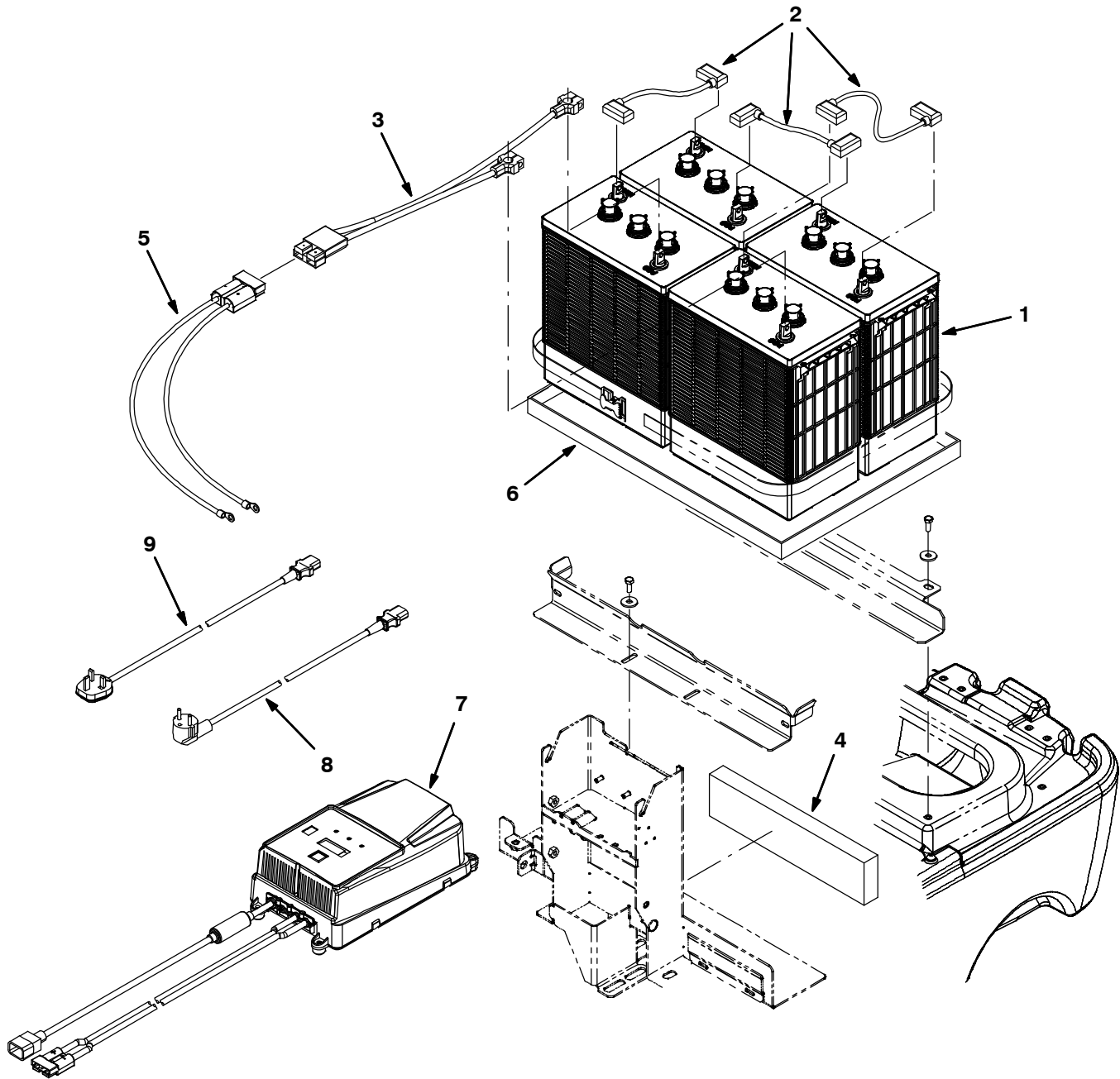

Ref.	Part No.	Description	Qty.
▽	9014959	Battery Kit Wet Monoblocs 4x6v/295ah/5h	1
▲	1 1070586	Battery, Wet, 06vdc 0360ah, W/o Carton	4
▲	2 1075160	Cable, Battery, 19 Mm2 029l Blk, 2clamp	3
▲	3 994890	Cable Assy, Battery, 25mm2, 2clamp, 175a	1
▲	4 630375	Spacer, Battery, Foam, 1.25 X 3.3 X 13.7	3
	5 994889	Cable Assy, 04ga 6.5ring /8.5ring, 175a	1
	6 994209	Tray, Battery, 615x425x30	1
▽	7 1071789	Charger, 24vdc 035a Wet Sb050r 230vac	1
▲	8 1043746	Cable, Charger Eu, Bc5 & Bc7	1
	9 1041716	Cable, Charger Uk, Bc5 & Bc7	1
	996275	Charger [On-Board, Eu/Uk]	1

NOTE: Models equipped with SPE on-board charger, located near battery compartment, are limited to a specific battery dimension. Battery selection: 1070586 – 360Ah Wet & 994229 – 240Ah Gel.

**Fig. 12 – Battery and Charger Group 255Ah/5H
(For Aftermarket Only)**

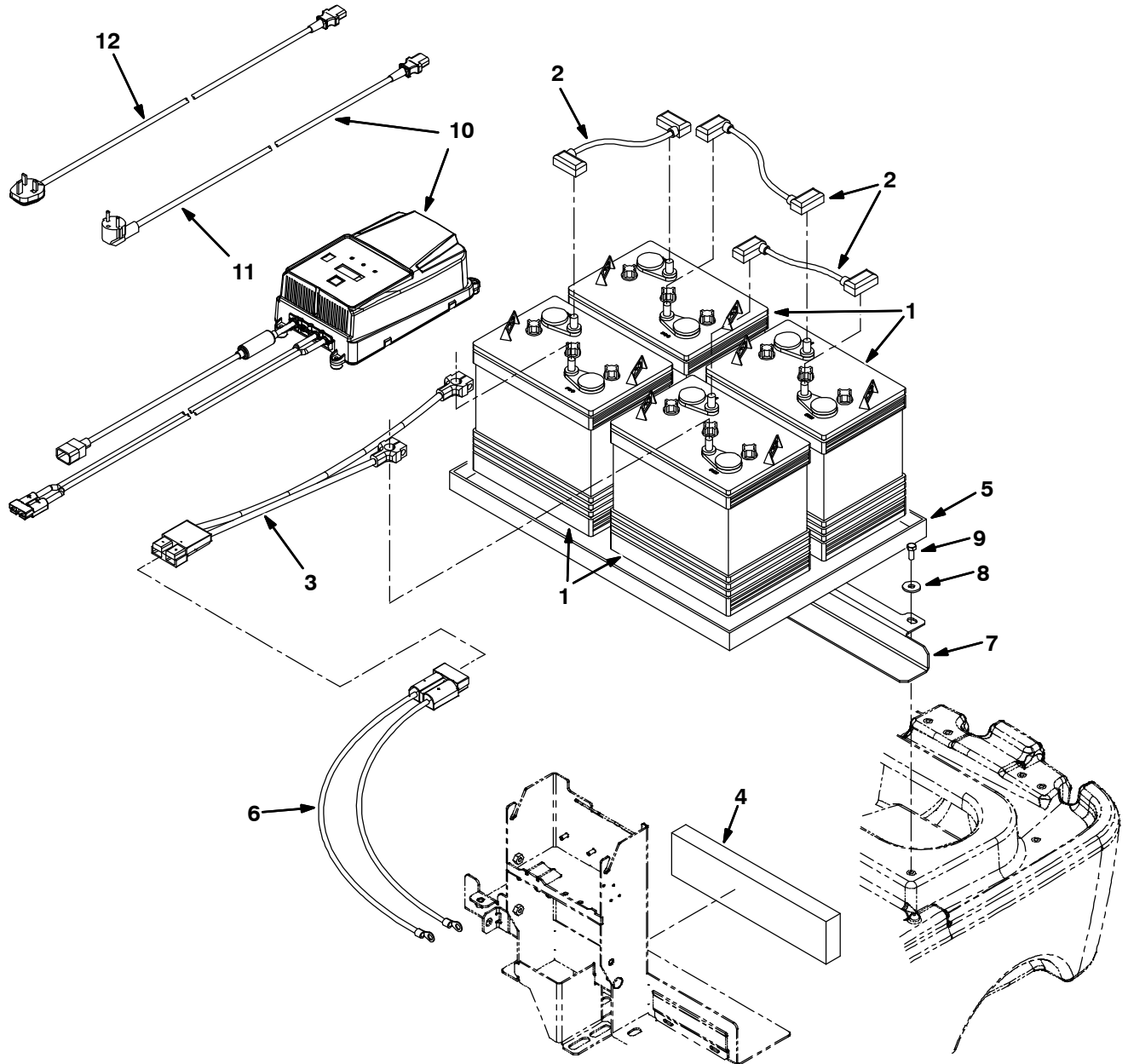

Ref.	Part No.	Description	Qty.
▽	994857	Battery Kit A T7 255ah/5h	1
▲	1 1041457	Battery, 6v/255ah5h [J305ghut]	4
▲	2 1075160	Cable, Battery, 19 Mm2 029l Blk, 2clamp	3
▲	3 994890	Wire Assy Connector Batt Sb175r	1
▲	4 630375	Spacer, Battery Foam	3
▲	5 994209	Tray, Battery, 615x425x30	1
	6 994889	Wire Assy Connector Sb175r	1
	7 1010771	Angle, Sppt, Battery	1
	8 1017218	Washer, Flat, 0.321b 1.00d .12, Ss	2
	9 09740	Screw, Hex, M8 X 1.25 X 20, Ss	2
▽	10 1071789	Charger, 24vdc 035a Wet Sb050r 230vac	1
▲	11 1043746	Cable, Charger Eu, Bc5 & Bc7	1
	12 1041716	Cable, Charger Uk, Bc5 & Bc7	1

NOTE: Models equipped with SPE on-board charger, located near battery compartment, are limited to a specific battery dimension. Battery selection: 1070586 – 360Ah Wet & 994229 – 240Ah Gel.

Fig. 13 – Battery and Charger Group 240Ah/5H

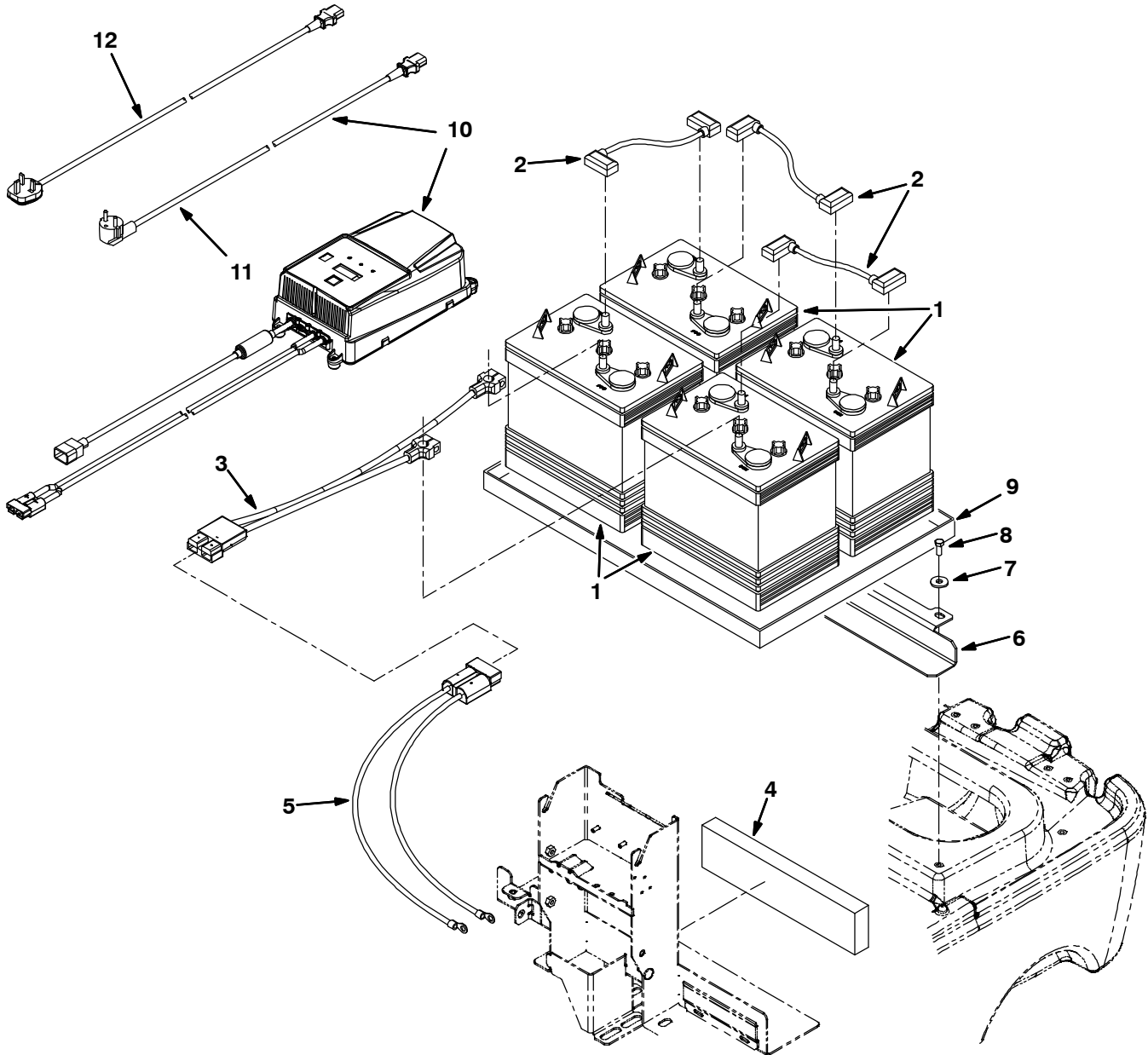

Ref.	Part No.	Description	Qty.
▽	994267	Battery Kit Mf Monoblocs 4x6v/240ah/5h	1
▲	1 994229	Battery, 6v / 240ah5h[Mf][Gf06240v]	4
▲	2 1075160	Cable, Battery, 19 Mm2 029l Blk, 2clamp	3
▲	3 994890	Wire Assy Connector Batt Sb175r	1
▲	4 630375	Spacer, Battery Foam	3
	5 994889	Wire Assy Connector Sb175r	1
	6 1010771	Angle, Sppt, Battery	1
	7 1017218	Washer, Flat, 0.321b 1.00d .12, Ss	2
	8 09740	Screw, Hex, M8 X 1.25 X 20, Ss	2
	9 994209	Tray, Battery, 615x425x30	1
▽	10 1071788	Charger, 24vdc 035a Gel Sb050r 230vac	1
▲	11 1043746	Cable, Charger Eu, Bc5 & Bc7	1
	12 1041716	Cable, Charger Uk, Bc5 & Bc7	1
	996275	Charger [On-Board, Eu/Uk]	1

NOTE: Models equipped with SPE on-board charger, located near battery compartment, are limited to a specific battery dimension. Battery selection: 1070586 – 360Ah Wet & 994229 – 240Ah Gel.

Fig. 14 – Battery and Charger Group 180Ah/5H

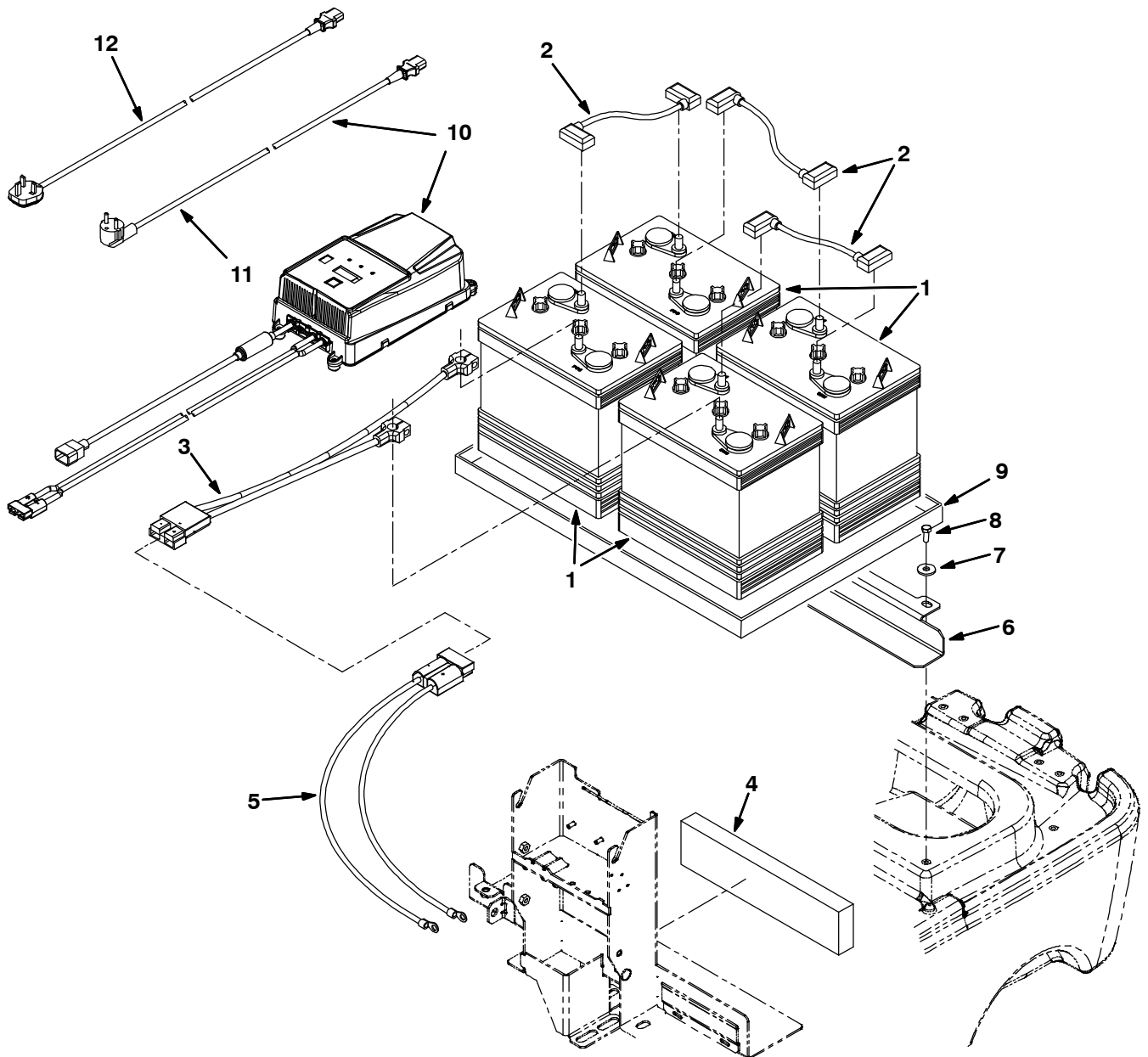

Ref.	Part No.	Description	Qty.
▽	9011231	Battery Kit, Mf [Monoblocs 4*6v/180ah/5h	1
▲	1 994203	Battery, 06vdc 0180ah [5h, Gf06180]	4
▲	2 1075160	Cable, Battery, 19 Mm2 029l Blk, 2clamp	3
▲	3 994890	Wire Assy Connector Batt Sb175r	1
▲	4 630375	Spacer, Battery Foam	5
	5 994889	Wire Assy Connector Sb175r	1
	6 1010771	Angle, Sppt, Battery	1
	7 1017218	Washer, Flat, 0.321b 1.00d .12, Ss	2
	8 09740	Screw, Hex, M8 X 1.25 X 20, Ss	2
	9 994209	Tray, Battery, 615x425x30	1
▽	10 1071786	Charger, 24vdc 025a Gel Sb050r 230vac	1
▲	11 1043746	Cable, Charger Eu, Bc5 & Bc7	1
	12 1041716	Cable, Charger Uk, Bc5 & Bc7	1

NOTE: Models equipped with SPE on-board charger, located near battery compartment, are limited to a specific battery dimension. Battery selection: 1070586 – 360Ah Wet & 994229 – 240Ah Gel.

Fig. 15 – Battery and Charger Group 24V/275Ah/5H

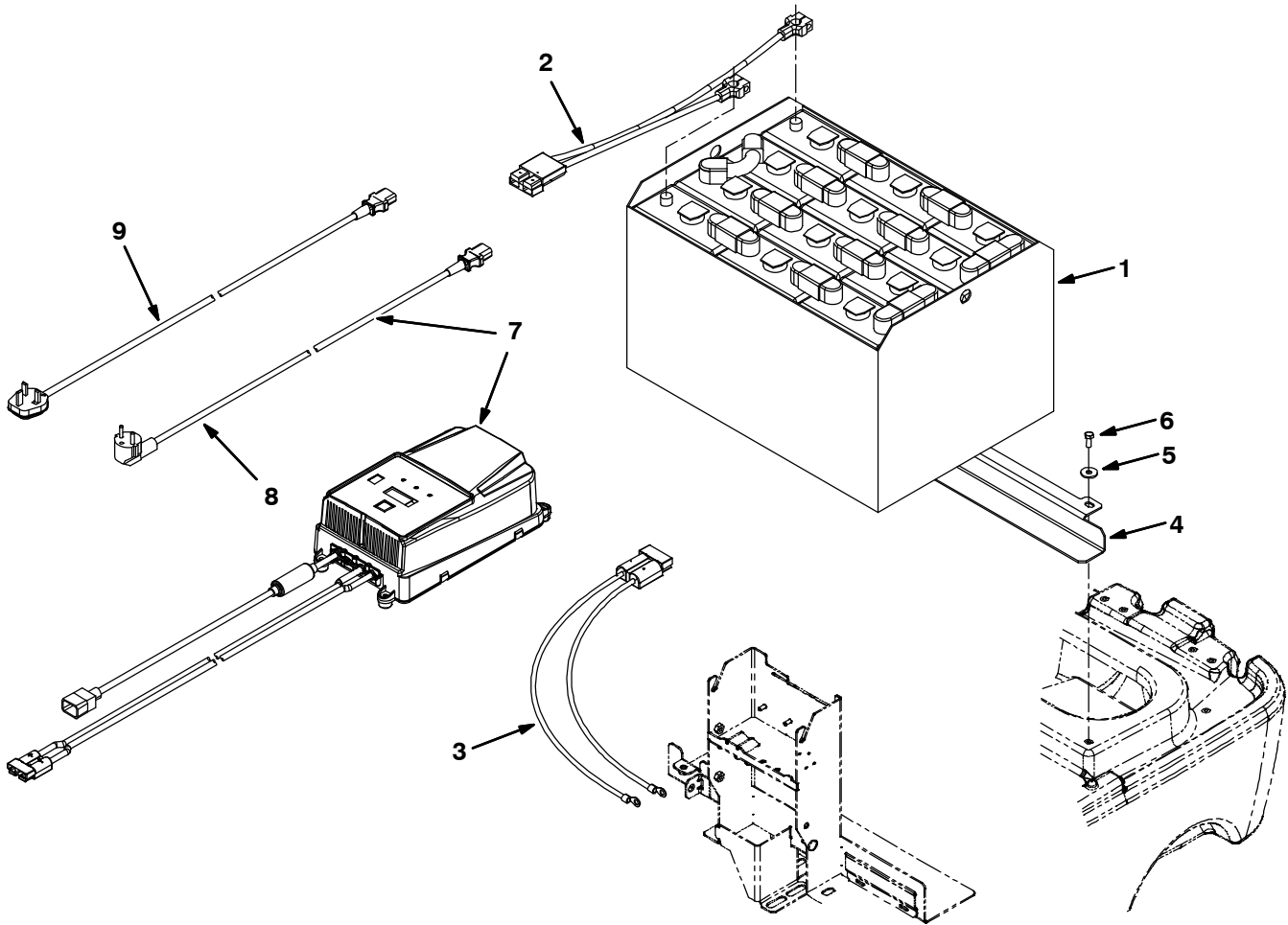

	Ref.	Part No.	Description	Qty.
▽		994858	Battery Kit Gel 24v/275ah5h	1
▲▽	1	994321	Battery Mf 24v/275ah/5h (5pzv275)	1
▲▲	2	0606010	Connector Anderson S175 Red	1
	3	994889	Wire Assy Connector Sb175r	1
	4	1010771	Angle, Sppt, Battery	1
	5	1017218	Washer, Flat, 0.321b 1.00d .12, Ss	2
	6	09740	Screw, Hex, M8 X 1.25 X 20, Ss	2
▽	7	1071788	Charger, 24vdc 035a Gel Sb050r 230vac	1
▲	8	1043746	Cable, Charger Eu, Bc5 & Bc7	1
	9	1041716	Cable, Charger Uk, Bc5 & Bc7	1

NOTE: Models equipped with SPE on-board charger, located near battery compartment, are limited to a specific battery dimension. Battery selection: 1070586 – 360Ah Wet & 994229 – 240Ah Gel.

Fig. 16 – Battery and Charger Group 24V/240Ah/5H

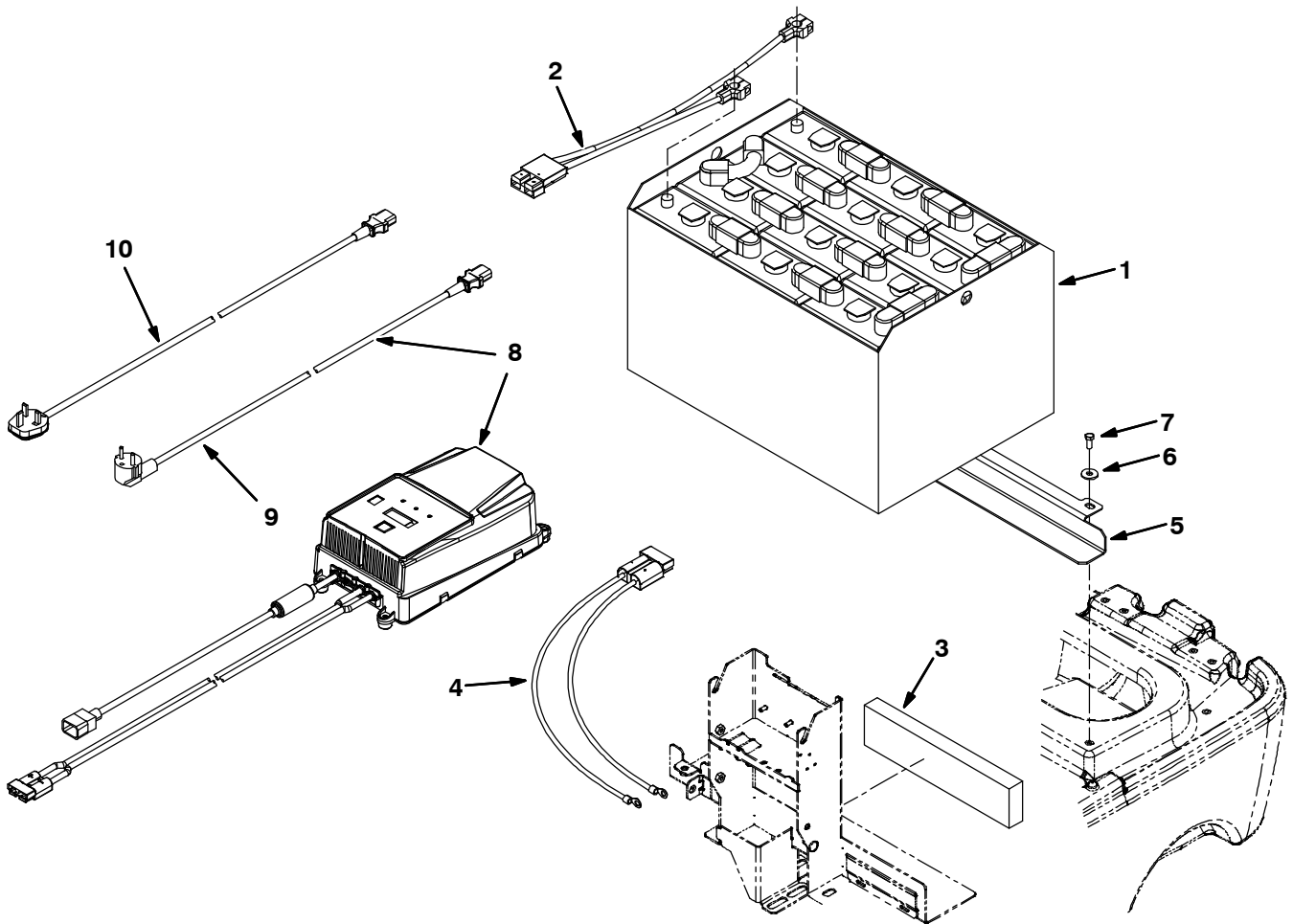

Ref.	Part No.	Description	Qty.
▽	994859	Battery Kit Traction 24v/240ah5h	1
▲▽	1 1041465	Battery, 24vdc 0240ah [5h, 4pzs240]	1
▲▲	2 0606010	Connector Anderson S175 Red	1
▲	3 630375	Spacer, Battery Foam	3
	4 994889	Wire Assy Connector Sb175r	1
	5 1010771	Angle, Sppt, Battery	1
	6 1017218	Washer, Flat, 0.321b 1.00d .12, Ss	2
	7 09740	Screw, Hex, M8 X 1.25 X 20, Ss	2
▽	8 1071789	Charger, 24vdc 035a Wet Sb050r 230vac	1
▲	9 1043746	Cable, Charger Eu, Bc5 & Bc7	1
	10 1041716	Cable, Charger Uk, Bc5 & Bc7	1

NOTE: Models equipped with SPE on-board charger, located near battery compartment, are limited to a specific battery dimension. Battery selection: 1070586 – 360Ah Wet & 994229 – 240Ah Gel.

Fig. 17 – Battery and Charger Group 24V/300Ah/5H

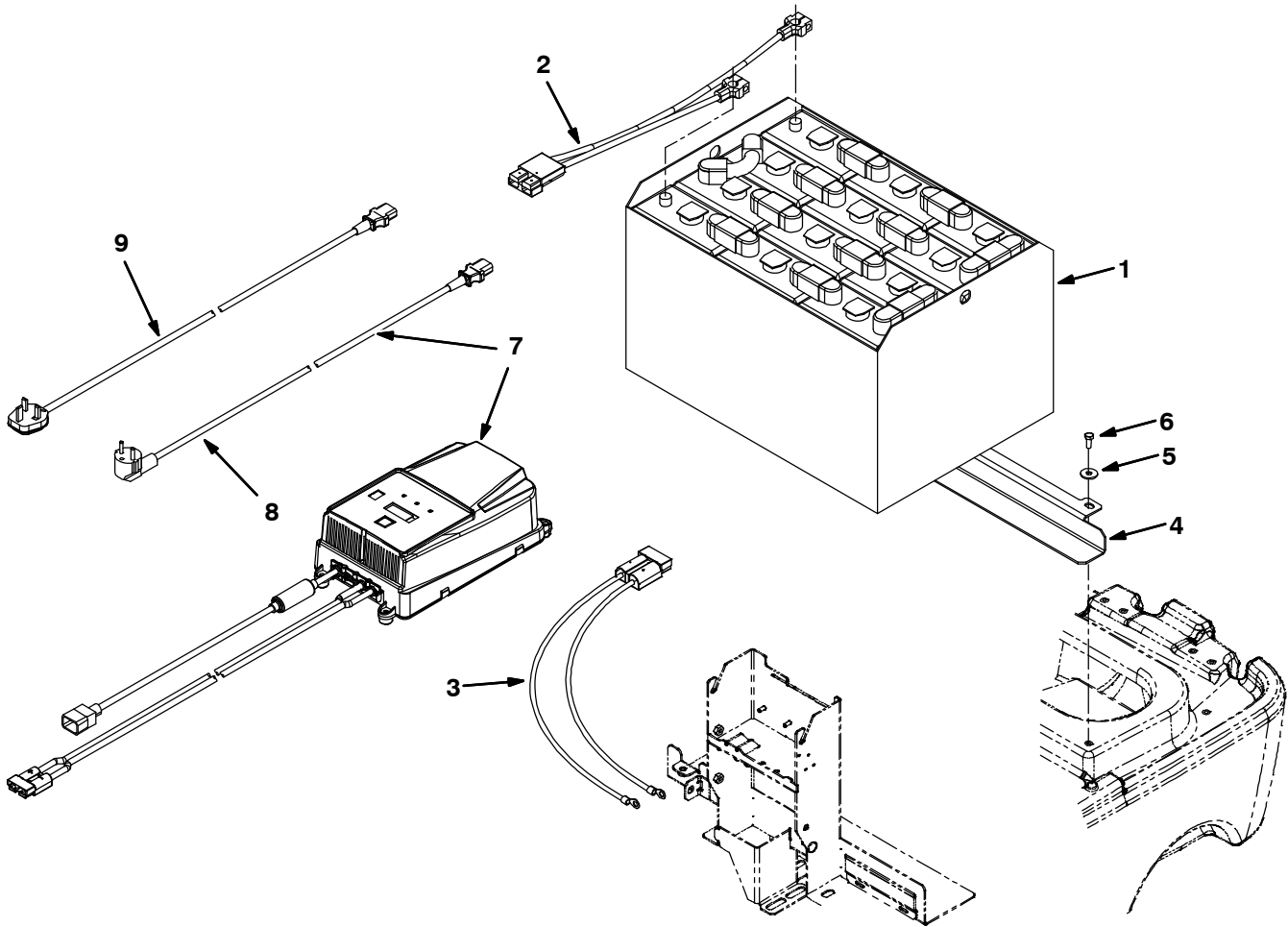

Ref.	Part No.	Description	Qty.
▽	994860	Battery Kit Traction 24v/300ah5h	1
▲▽	1 1262301	② Battery, 24vdc 300ah [5pg250l]	1
	1 1041466	① Battery 24v/300ah/5h (11cd300) (No Longer Available)	1
▲▲	2 0606010	Connector Anderson S175 Red	1
	3 994889	Wire Assy Connector Sb175r	1
	4 1010771	Angle, Sppt, Battery	1
	5 1017218	Washer, Flat, 0.321b 1.00d .12, Ss	2
	6 09740	Screw, Hex, M8 X 1.25 X 20, Ss	2
▽	7 1071791	Charger, 24vdc 040a Wet Sb050r 230vac	1
▲	8 1043746	Cable, Charger Eu, Bc5 & Bc7	1
	9 1041716	Cable, Charger Uk, Bc5 & Bc7	1

① Serial number (10000–18643)

② Serial number (18644–)

NOTE: Models equipped with SPE on-board charger, located near battery compartment, are limited to a specific battery dimension. Battery selection: 1070586 – 360Ah Wet & 994229 – 240Ah Gel.

Fig. 18 – Flashing Light Group

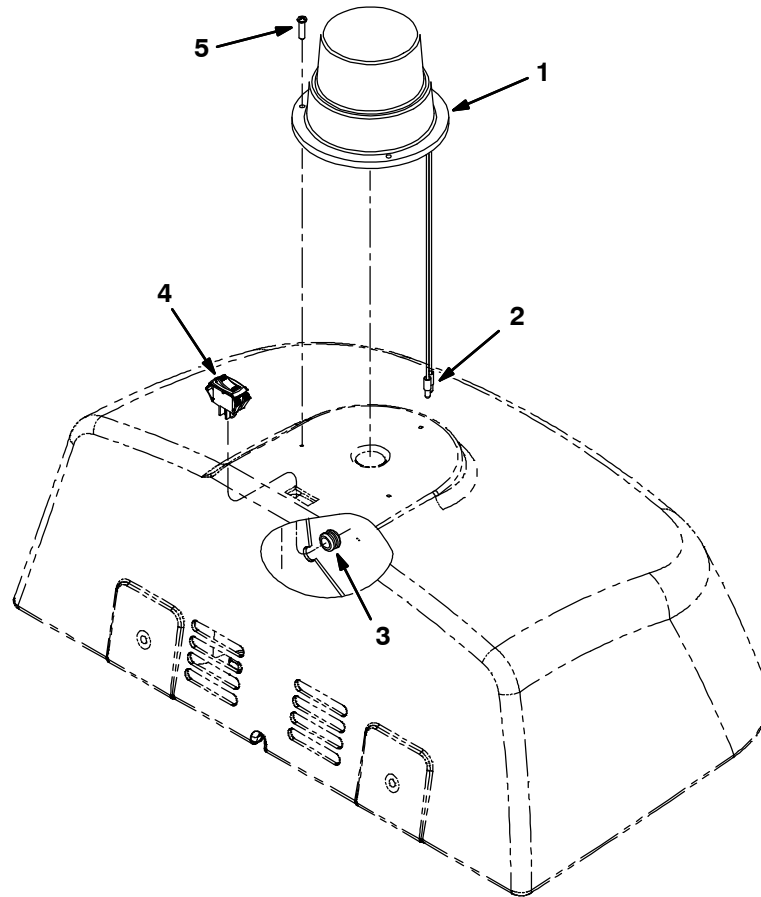

Ref.	Part No.	Description	Qty.
1	1018791	Light, Flsh (Does Not Include Terminals – Need to Order Qty 2 of #55272)	1
2	55272	Terminal, Bullet, Mal, .157d, 12ga	2
3	10632-12	Grommet, Rbr, 0.38id, F/ 0.5h, .12matl	1
4	130717	Switch, Rocker, 250vac 15a Spst On/Off	1
5	360943	Screw, Pan, #10-14 X 0.75, F/Plstc	3

Fig. 19 – Documentation Group (Online Only)

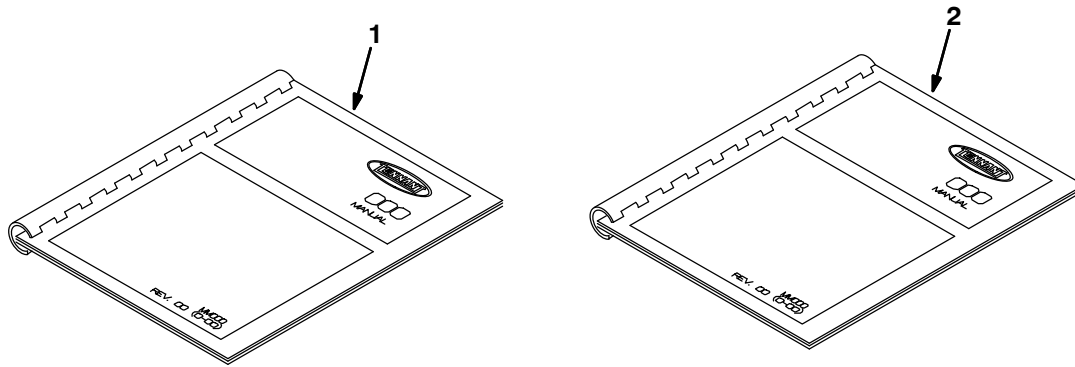

Ref.	Part No.	Description	Qty.
1	9013336	Manual, Parts [T7+, En, Ce]	1
2	9013319	Manual, Oprtr [T7+, Cz, Ce]	1
2	9013320	Manual, Oprtr [T7+, De, Ce]	1
2	9013321	Manual, Oprtr [T7+, Dk, Ce]	1
2	9013318	Manual, Oprtr [T7+, En, Ce]	1
2	9013322	Manual, Oprtr [T7+, Es, Ce]	1
2	9013323	Manual, Oprtr [T7+, Fi, Ce]	1
2	9013324	Manual, Oprtr [T7+, Fr, Ce]	1
2	9013325	Manual, Oprtr [T7+, Gr, Ce]	1
2	9013326	Manual, Oprtr [T7+, Hu, Ce]	1
2	9013327	Manual, Oprtr [T7+, It, Ce]	1
2	9013328	Manual, Oprtr [T7+, Nl, Ce]	1
2	9013329	Manual, Oprtr [T7+, No, Ce]	1
2	9013330	Manual, Oprtr [T7+, Pl, Ce]	1
2	9013331	Manual, Oprtr [T7+, Pt, Ce]	1
2	9013332	Manual, Oprtr [T7+, Ru, Ce]	1
2	9013333	Manual, Oprtr [T7+, Se, Ce]	1
2	9013373	Manual, Oprtr [T7+, Tr, Ce]	1
2	9013370	Manual, Oprtr [T7+, Ro, Ce]	1
2	9013371	Manual, Oprtr, Ce [T7+, Bg]	1
2	9013372	Manual, Oprtr, Ce [T7+, Lt]	1
2	9013415	Manual, Oprtr, Ce [T7+, Lv]	1
2	9013374	Manual, Oprtr [T7+, Ee, Ce]	1
2	9013375	Manual, Oprtr [T7+, Si, Ce]	1
2	9013334	Manual, Oprtr [T7+, Sk, Ce]	1
2	9013335	Manual, Oprtr [T7+, Hr, Ce]	1



To view, print, order, download the latest Parts manual, other language Operator manuals, and Use and Care Guides (wall charts), visit:

www.tennantco.com/manual

SECTION 4

Contents	Page
Fig. 1 – Steering Control Breakdown, 1019724 . . .	4-2
Fig. 2 – FaST Injector Assembly Breakdown, 9008885	4-3
Fig. 3 – ec-H2O NanoClean Module Breakdown, 9020643, 9021553 (S/N 16186–) . . .	4-4
Fig. 4 – ec-H2O NanoClean Module Breakdown, 9011810 (S/N 11000–16185)	4-6
Fig. 5 – ec-H2O Module Assembly Breakdown, 9007970 (S/N 10000–10999)	4-8
Fig. 6 – Vacuum Fan Motor Breakdown, 1021064, 1256475	4-10
Fig. 7 – Front Wheel Gearbox Breakdown, 9008999	4-12

Fig. 1 – Steering Control Breakdown, 1019724

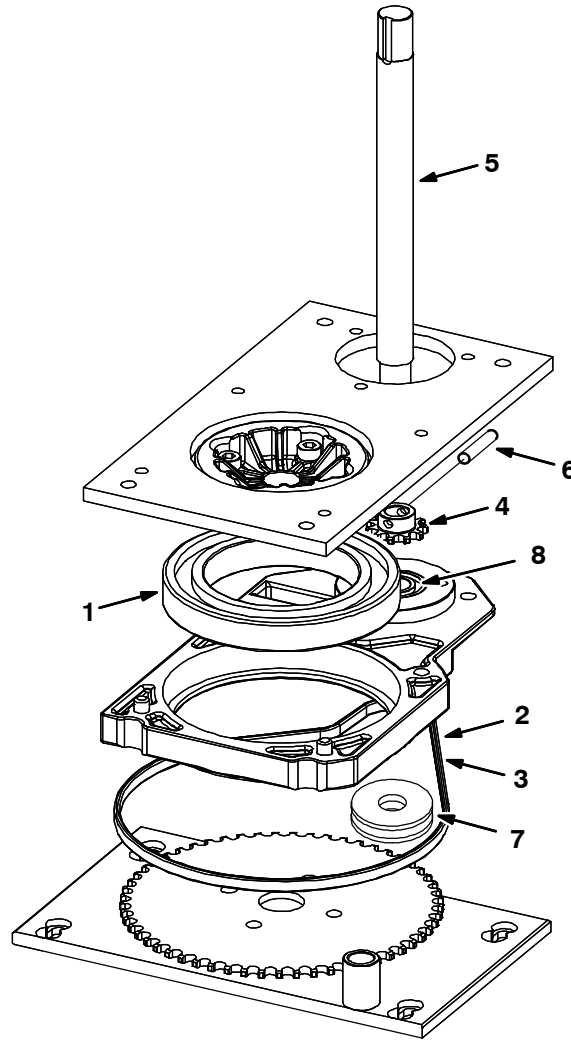

Ref.	Part No.	Description	Qty.
▽	1019724	Steer-Control Assy, Wheel Drive	1
▲	1 372874	Bearing, Steering	1
▲	2 372875	Chain, Steering	1
▲	3 372876	Link, Master	1
▲	4 372881	Sprocket	1
▲	5 1029229	Shaft, Steering	1
▲	6 1038313	Vr, Pin, Roll, 06mm X 28mm[T7/Ssrsteer]	1
▲	7 9011051	Vr, Pulley, Tens	1
▲	8 9008719	Vr, Bearing [6003 2rs]	2

Fig. 2 – FaST Injector Assembly Breakdown, 9008885

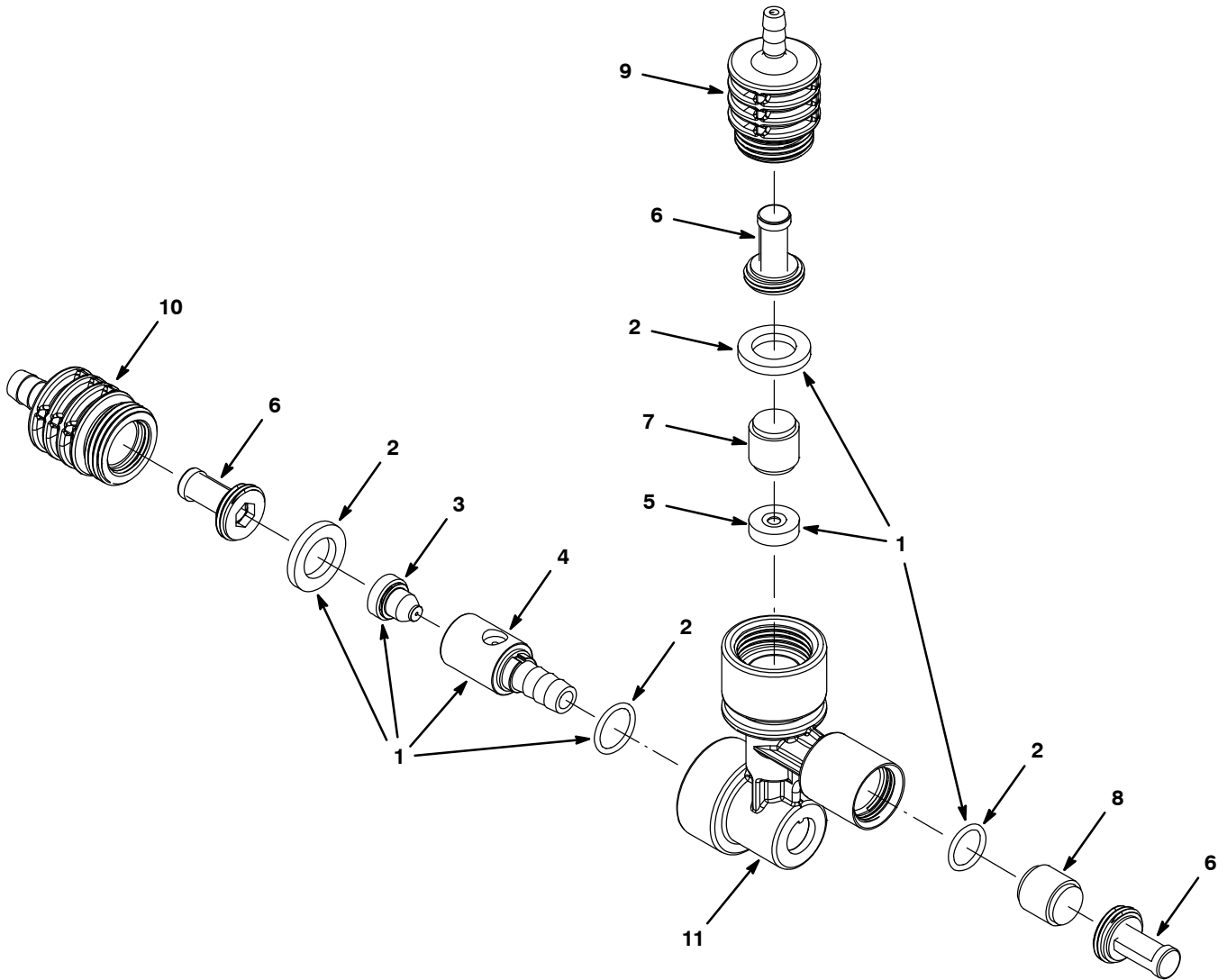

Ref.	Part No.	Description	Qty.
▽	9008885	Fast Kit, Injector, Ci[T7/Ssr/T16 Fast3]	1
▲▽	1	Fast Kit, Ci [Inj Rebl, T7/Ssr/T16, lii]	1
▲▲	2	Fast Kit, Seal, Injector, Ci [Fast lii]	1
▲▲	3	Plug, Orifice, 0.041, Ss [Fast li+]	1
▲▲	4	Insert, Venturi, Medium, [Fast lii]	1
▲▲	5	Plate Assy, Orifice, 0.0090id, Natural	1
▲	6	Fast Kit, Ci, Injector Filters[Fast li+]	1
▲	7	Valve, Check, 0002psi [Fast li+]	1
▲	8	Valve, Check, 0005psi [Fast li+]	1
▲	9	Housing, Fltr, Upper [Fast lii]	1
▲	10	Housing, Fltr, Lower [Fast lii]	1
▲	11	Housing, Body, Injector [Fast lii]	1

BREAKDOWN

Fig. 3 – *ec-H2O* NanoClean Module Breakdown, 9020643, 9021553 (S/N 16186–)

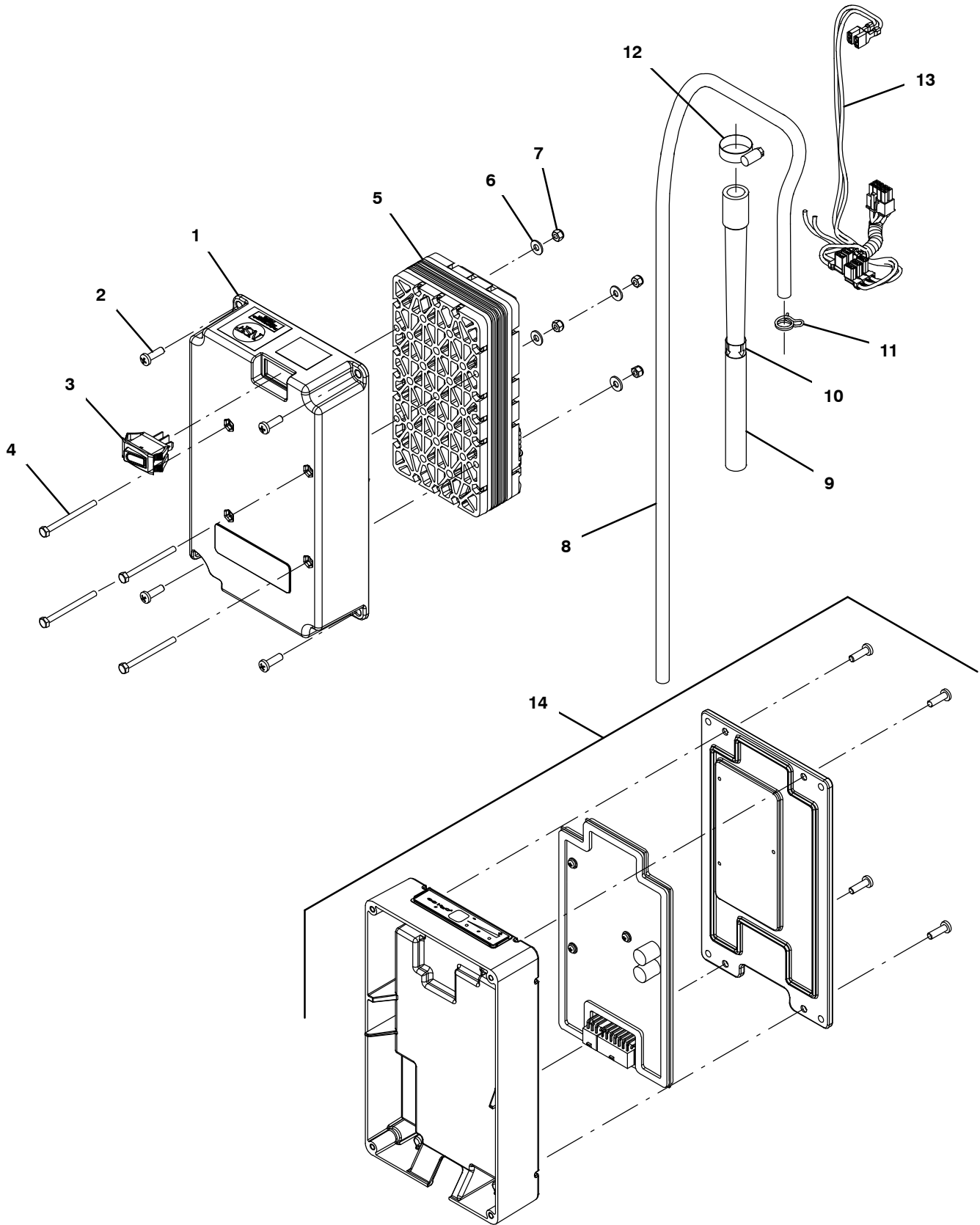

Fig. 3 – ec-H2O NanoClean Module Breakdown, 9020643, 9021553 (S/N 16186–)

Ref.	Part No.	Description	Qty.
▽	9021553	⑤ Module Kit, Replmt [Ec-H2o, B 02] (Includes ec-H2O NanoClean Cartridge)	1
▽	9020643	④ Module Kit, Replmt [Ec-H2o, B 02] (Includes ec-H2O NanoClean Cartridge) (Replaced By 9021553)	1
▲▽	9014126	② Ec-H2o Nc Kit [Module B, Plumbing]	1
▲▲	1 1208823	② Housing, Module, Upper, Ec-H2o	1
▲▲	2 1015506	② Screw, Pan, Phl, M5 X 16, Tcut [Plastic]	4
▲▲	3 1044393	② Switch, Rocker, Spst, Mom	1
▲▲	4 32509	② Screw, Hex, M4 X 0.70 X 50, Ss	4
▲▲	5 1233516	④ Electrode, 5 Plate [De Nora Tech]	1
▲▲	6 41579	② Washer, Flat, 08, Ss	4
▲▲	7 33932	② Nut, Hex, Lock, M4 X 0.70, Ni, Ss	4
▲▲	8 1006415	② Hose, Afmkt, Pvc,Clr, 0.25id, 03ft	1
▲▲	9 1208526	② Hose, Molded, Bm08/Bm06	1
▲▲	10 1049637	② Label, Direction [Ec-H2o]	1
▲▲	11 613735	② Clamp, Hose, Wir, .40 – .42, Yel	1
▲▲	12 54333	② Clamp, Hose, Wormdrive, 0.31–0.88d, .31w	1
▲▲	13 1073286	② Harness, Ele, Module B2 [Ec-H2o]	1
▲	14 9020642	④ Controller Kit, Replmt [Ec-H2o Nc] (Includes ecH2O NanoClean Cartridge)	1

② Serial number (11000–)

④ Serial number (16186–AUG2022)

⑤ Serial number (SEP2022–)

BREAKDOWN

Fig. 4 – *ec-H2O* NanoClean Module Breakdown, 9011810 (S/N 11000–16185)

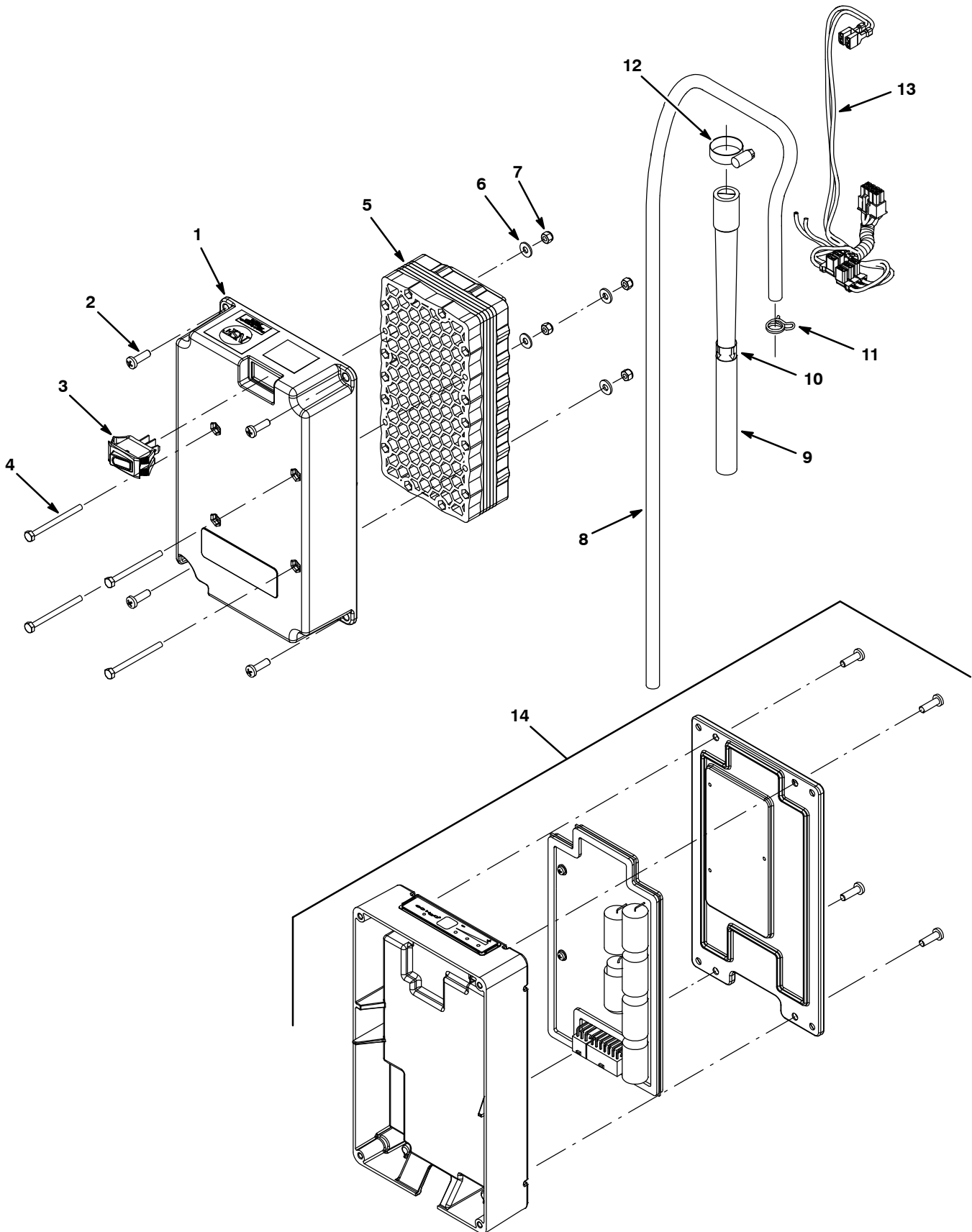

Fig. 4 – *ec-H2O* NanoClean Module Breakdown, 9011810 (S/N 11000–16185)

Ref.	Part No.	Description	Qty.
▽	9011810	③ Module Kit, Replmt [Ec-H2o, B 02] (Includes ec-H2O NanoClean Cartridge) (Replaced By 9021553)	1
▲▽	9014126	② Ec-H2o Nc Kit [Module B, Plumbing]	1
▲▲	1 1208823	② Housing, Module, Upper, Ec-H2o	1
▲▲	2 1015506	② Screw, Pan, Phl, M5 X 16, Tcut [Plastic]	4
▲▲	3 1044393	② Switch, Rocker, Spst, Mom	1
▲▲	4 32509	② Screw, Hex, M4 X 0.70 X 50, Ss	4
▲▲	5 1208164	③ Electrode, 5 Plate, High Flow (Replaced By 1233516)	1
▲▲	6 41579	② Washer, Flat, 08, Ss	4
▲▲	7 33932	② Nut, Hex, Lock, M4 X 0.70, NI, Ss	4
▲▲	8 1006415	② Hose, Afmkt, Pvc, Clr, 0.25id, 03ft	1
▲▲	9 1208526	② Hose, Molded, Bm08/Bm06	1
▲▲	10 1049637	② Label, Direction [Ec-H2o]	1
▲▲	11 613735	② Clamp, Hose, Wir, .40 – .42, Yel	1
▲▲	12 54333	② Clamp, Hose, Wormdrive, 0.31–0.88d, .31w	1
▲▲	13 1073286	② Harness, Ele, Module B2 [Ec-H2o]	1
▲	14 9014127	③ Controller Kit, Replmt [Ec-H2o Nc] (Includes ec-H2O NanoClean Cartridge) (Replaced By 9020642)	1

② Serial number (11000–)

③ Serial number (11000–16185)

Fig. 5 – ec-H2O Module Assembly Breakdown, 9007970 (S/N 10000–10999)

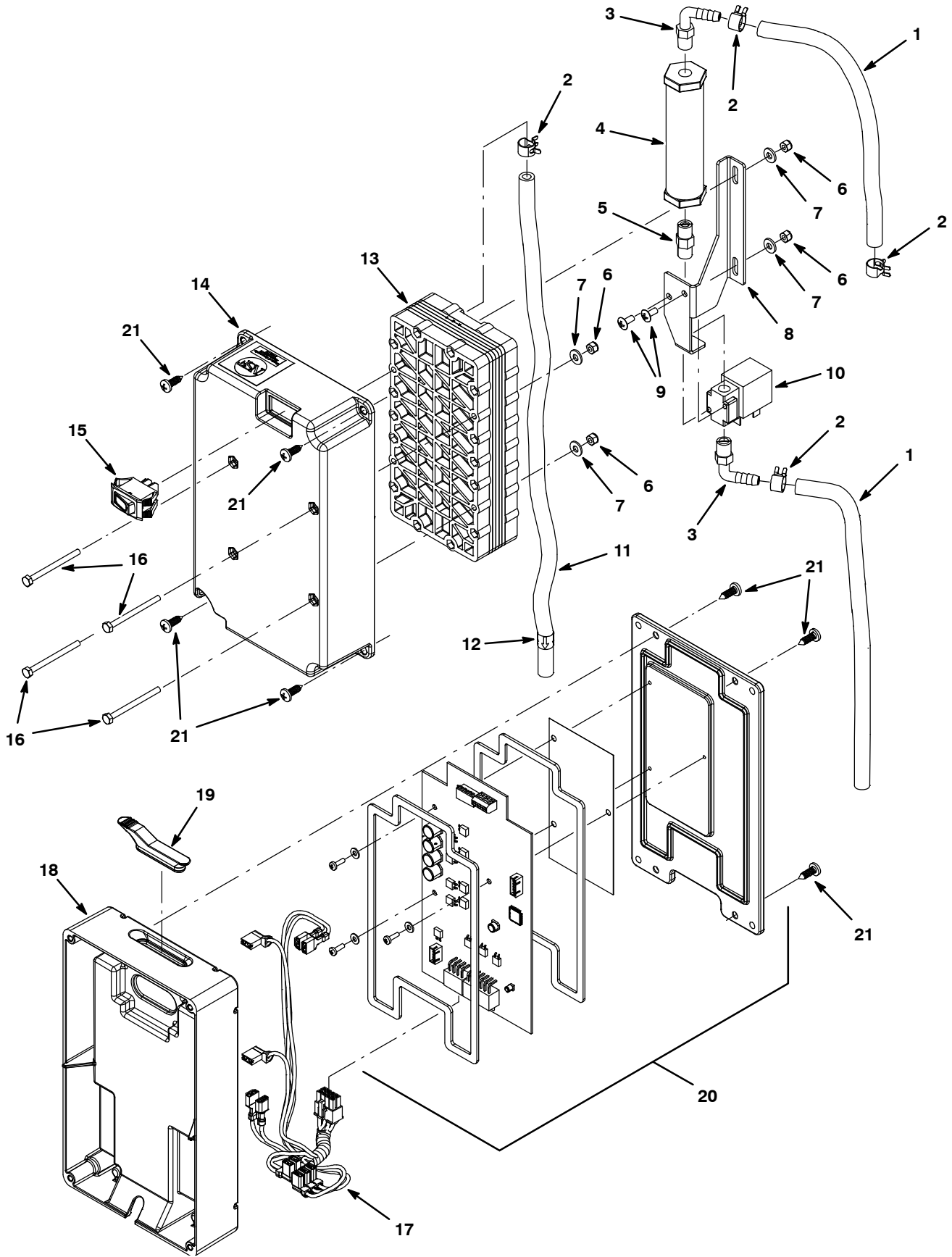

Fig. 5 – *ec-H2O* Module Assembly Breakdown, 9007970 (S/N 10000–10999)

Ref.	Part No.	Description	Qty.
▽	9007970	☐ Module Kit, Replmt [Ec-H2o]	1
▲▽	9006324	☐ Ec-H2o Kit, Module B, Plumbing	1
▲▲	1 578820000	☐ Hose, Pvc, Brd, 0.25id 0.44od 157.2l,Clr	1
▲▲	2 603654	☐ Clamp, Hose, Ear, .44d [Ctb]	4
▲▲	3 1037595	☐ Fitting, Plstc, E90, Bm04/Pm02, Nyl	2
▲▲	4 1062006	☐ Electrode, Cylindrical	1
▲▲	5 1045030	☐ Fitting, Brs, Str, Pm02/Pm02	1
▲▲	6 33932	☐ Nut, Hex, Lock, M4 X 0.70, Ni, Ss	4
▲▲	7 41579	☐ Washer, Flat, 08, Ss	4
▲▲	8 1048490	☐ Bracket, Valve	1
▲▲	9 140801	☐ Screw, Trs, Phl, 08-32 X 0.38, Ss	2
▲▲	10 1013236	☐ Valve, Shutoff, Ele, 24vdc	1
▲▲	11 9006574	☐ Hose, Pvc, Brd, 0.25id 0.45od, 65l, Clr	1
▲▲	12 1049637	☐ Label, Direction [Ec-H2o]	1
▲▲	13 1057637	☐ Electrode, 5 Plate, High Flow	1
▲▲	14 1051519	☐ Housing, Upper, Module, High Flow	1
▲▲	15 1044393	☐ Switch, Rocker, Spst, Mom	1
▲▲	16 32509	☐ Screw, Hex, M4 X 0.70 X 50, Ss	4
▲▲	17 1049489	☐ Harness, Main,Controlboard[Ec-H2o 5cell]	1
▲	18 1037032	☐ Housing, Bottom	1
▲	19 1054776	☐ Grommet, Blind	1
▲	20 9007969	☐ Controller Kit, Replmt [Ec-H2o]	1
▲	21 1018155	☐ Screw, Pan, Phl, M5 X 0.80 X 16, Tcut,Ss	8

☐ Serial number (10000–10999)

Fig. 6 - Vacuum Fan Motor Breakdown, 1021064, 1256475

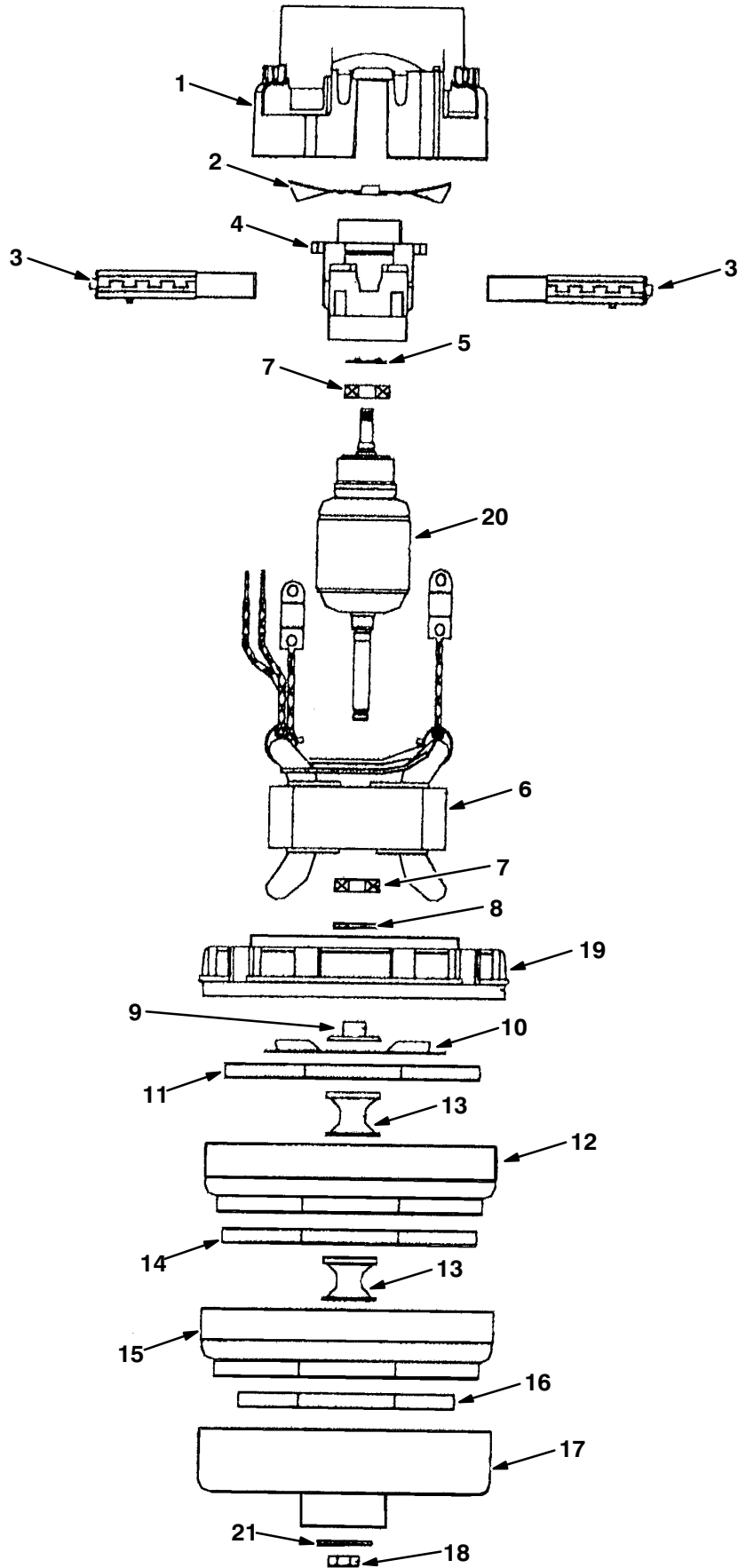

Fig. 6 – Vacuum Fan Motor Breakdown, 1021064, 1256475

Ref.	Part No.	Description	Qty.
▽	1256475	④ Fan, Vacuum, 5.7d, 024vdc, 3 Stage [Bpp]	1
▽	1021064	③ Fan, Vacuum, 5.7d, 024vdc, 3 Stage [Bpp] (Replaced By 1256475)	1
▲	1 398511	Housing	1
▲	2 398512	Fan	1
▲	3 372883	Brush Kit, Motor, Ele	1
▲	4 398514	Bracket	1
▲	5 01856	Spring, Brg, Motor, Vacfan	1
▲	6 372885	Commutator	1
▲	7 01837	Bearing, Motor, Vacfan	2
▲	8 372886	Washer	1
▲	9 398516	Spacer	1
▲	10 01971	Impeller, Vacfan	1
▲	11 372888	Impeller, Fan	1
▲	12 60387	Fan	1
▲	13 398517	Spacer	2
▲	14 18628	Impeller, Vacfan	1
▲	15 61297	Housing, Impeller, Vacfan	1
▲	16 372889	Impeller, Fan	1
▲	17 372890	Shell, Fan	1
▲	18 37929	Nut, Impeller, Vacfan	1
▲	19 372887	Bracket, End, Fan	1
▲	20 372884	Armature	1
▲	21 378983	Washer	1
▲	223264	Seal, Rbr, Clsd, 0.25th, 5.8d 03.3h	1
▲	10925	Connector, Fem, 2cav [Mp630 Sealed]	1
▲	24537	Terminal, Fem, 10/12ga [Mp630 P2s]	2

③ Serial number (10000–17909)

④ Serial number (17910–)

Fig. 7 – Front Wheel Gearbox Breakdown, 9008999

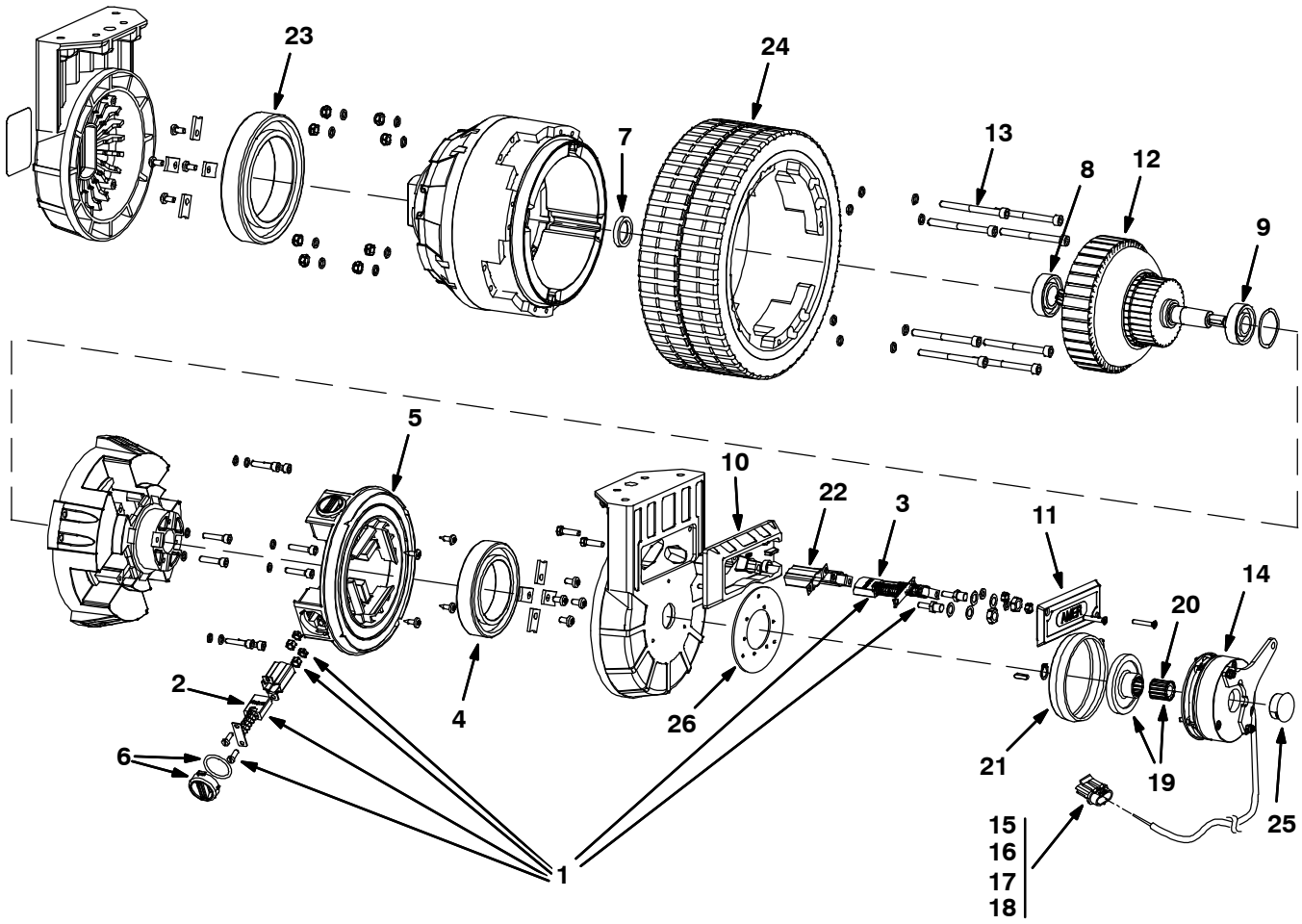

Fig. 7 – Front Wheel Gearbox Breakdown, 9008999

Ref.	Part No.	Description	Qty.
▽	9008999	Gearbox Kit, Wheel, 250mm, W/ Connector	1
▲	1 391261	Brush Kit, Motor [Amer, 1pick=1 bag] (1 Kit = 6 Brushes)	1
▲▽	1029225	Brush Kit, Carbon (1 Kit = 4 Brushes)	1
▲▲	2 1029224	Brush, Carbon (1 Brush)	4
▲▽	1029226	Brush Kit, Carbon, Curve (1 Kit = 2 Brushes)	1
▲▲	3 398492	Brush, Motor, Ele [Amer] Curve (1 Brush)	2
▲	4 1029227	Bearing, Ball, Brush Side	1
▲	5 1029228	Ring, Brushholder	1
▲	6 391262	Brush Kit, Cover [Amer]	4
▲	7 391263	Seal, Ring [Amer]	1
▲	8 391264	Bearing, Gearbox Side [Amer]	1
▲	9 391265	Bearing, Motor Side [Amer]	1
▲	10 391467	Box, Ele, Connection	1
▲	11 391468	Cover, Ele, Connection	11
▲	12 372867	Armature	1
▲	13 1029218	Screw, Mount, Wheel	8
▲▽	14 9008896	Brake Kit, W/Connector	1
▲▲	15 78950	Connector, Fem, 02cav, Mp280 Sealed	2
▲▲	16 78952	Lock, Secondary, 2cav, Mp280 Sealed	2
▲▲	17 25837	Terminal, Fem, Mp280, Sealed, 22–20ga	2
▲▲	18 25830	Seal, Wire, 14ga [Wp / Mp280 Sealed]	2
▲▲	19 372870	Vr, Disc, Brake (Set Includes Spline)	1
▲▲	20 372871	Adapter, Brake, Spl (NLA – Replaced By Set 372870)	1
▲	21 372872	Sleeve, Rbr	1
▲	22 372877	Guide, Brushholder, Slip Ring [Amer]	1
▲	23 372874	Bearing, Steering	1
▲	24 391259	Tire, Solid, 250mm X 90mm Red	1
▲	25 130161	Plug, Hole, Rnd, 0.88d, Blk	1
▲	26 9010971	Vr, Flange, Brake, T7	1